



## Digital Proximity System

### Installation Manual

---



The DPS (Digital Proximity System) family consists of two devices, the MX2033 and MX2034. The MX2033 is a conventional 3-wire driver while the MX2034 is a two-wire current loop transmitter with an optional two wires for buffered raw signal output. Users can configure either unit to measure peak-to-peak vibration, gap distance, or rotational speed. These products are used in conjunction with a proximity probe and extension cable to measure the vibration levels, gap distances, or rotational speed of machinery shafts. Users can also configure the units via a USB cable and configuration software.

## SAFETY TERMS AND SYMBOLS

Terms that appear in this manual requiring special attention include:

- **WARNING:** Warning statements identify conditions or practices that could result in injury or loss of life.
- **CAUTION:** Caution statements identify conditions or practices that could result in damage to the product, loss or corruption of data, or damage to the environment or other property.
- **NOTE:** Notes identify material of special interest or importance to the user, not including cautions or warnings.

Symbols that may appear on the product and/or in this manual include:

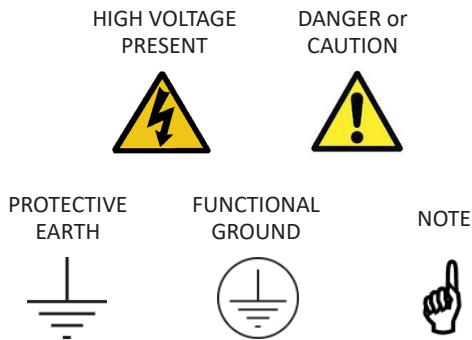

## GENERAL SAFETY SUMMARY

Review the following safety precautions to avoid injury and prevent damage to this product or any products connected to it.

- **USE ONLY AS SPECIFIED**  
To avoid potential hazards, use this product only as specified. Only qualified personnel should perform installation and uninstallation procedures.
- **OBSERVE ALL TERMINAL RATINGS**  
To avoid fire or shock hazard, observe all ratings and markings on the product. Consult the individual sections of this manual for further ratings information before making connections to the product.
- **AVOID EXPOSURE TO CIRCUITRY**  
Do not touch exposed electrical connections and components when power is present.
- **DO NOT OPERATE WITH SUSPECT FAILURES**  
If you suspect there is damage to this product, have it inspected by qualified personnel.

## **RECEIVING, INSPECTING AND HANDLING THE SYSTEM**

Metrix ships the probe, extension cable, and driver as separate units that the user interconnects at the installation site. Carefully remove all equipment from the shipping containers and inspect it for shipping damage. If you see shipping damage, file a claim with the carrier and submit a copy to Metrix Instrument Co. Include part numbers and serial numbers on all correspondence. If no damage is apparent and the equipment is not going to be used immediately, return the equipment to the shipping containers and reseal until ready for use. Store the equipment in an environment that is free from potentially damaging conditions such as extreme temperature, excessive humidity, or a corrosive atmosphere.

## **OVERVIEW**

The Metrix Digital Proximity System comes in two versions:

- MX2033 – 3-wire proximity driver
- MX2034 – 2-wire loop-powered proximity transmitter with an optional 2-wires for buffered raw signal output

The followings sections cover each of these in more detail.

### **MX2033 Three-Wire Proximity Driver**

The MX2033 signal output is compatible with industry-standard continuous-vibration monitoring systems and is the format specified in API Standard 670. It uses -24VDC excitation and provides the output signal in mV/mm, typically 7.87 mV/mm (200mV/mil) for 5 mm and 8mm probes and 3.94 mV/mm (100 mV/mil) for 11 mm probes.

### **MX2034 Two and Four - Wire Vibration / Position / Speed Transmitter**

The MX2034 signal format is for use when vibration, axial position, or rotational speed measurements will be directly connected to a PLC, DCS, SCADA system, or other instrumentation that accepts an ISA standard 4-20 mA signal, without the use of a separate monitor system. It is powered by +24 VDC, supplied within the current loop. Two optional wires from 4-pin connector can be used with a monitoring system within 30 meters (100ft). The device is configurable to function as either a radial vibration transmitter (where the 4-20 mA signal is proportional to peak-peak vibration amplitude), as an axial position transmitter (where the 4-20 mA signal is proportional to average probe gap) or as a rotational speed transmitter (where the 4-20mA signal is proportional to shaft speed). For convenience when connecting to signal analyzers, portable data collectors, and test instrumentation, the raw vibration / speed signal is available at a short-circuit protected BNC connector, and the two optional wires from 4-pin connector.

## **INSTALLATION**

### **Probe Installation**

Mount the probe in a simple bracket, such as the Metrix Model 7646, in a tapped hole in the bearing cap or by means of a Metrix Model 5499 Probe Housing. The latter arrangement provides an easy means to adjust the probe air gap, especially where the target is some distance from the outside surface of the machine.

When inserting the probe through the machine case or bearing cap, the signal voltage may vary widely before the proper gap is obtained. Therefore, be sure the gap is within 0.07" (1.8

mm) of the target before attempting to set the gap electrically. If possible, set the probe gap while the machine is shutdown, to avoid the danger of damaging the probe in the event that it touches the shaft.

Connect the probe to the driver/transmitter using the proper extension cable. If a connector must be replaced, the overall length of the probe or extension cable can be reduced by 2" total without adversely affecting the calibration and linearity. Insulate the probe connector/extension cable connector junction with the Metrix 8973 connector insulator.

### Radial vibration measurements

For radial vibration measurements, mount the probe perpendicular to the shaft with the probe tip approximately 0.050" (1.25 mm) from the shaft surface. Provide the probe tip with sufficient clearance from surrounding metal to prevent an erroneous output. As a minimum, the clearance diameter should be 0.75" (19 mm) for the full length of the probe tip. See Figure 1. You can set the probe gap "electrically" to the center of its measurement range by observing the DC output voltage at the BNC connector on the MX2034 or the terminal block connection on the MX2033 / MX2034 with an isolated meter. Adjust the probe gap to obtain -10 VDC, which corresponds to a gap of approximately 0.050" (1.25 mm). The preferred static gap range is 0.035" to 0.050". This gap corresponds to a voltage of -7.0 VDC to -10 VDC. To prevent cross-feed between two probes mounted in the same vicinity, maintain a minimum 1.0" (25 mm) spacing between the probe tips. See Figure 2.

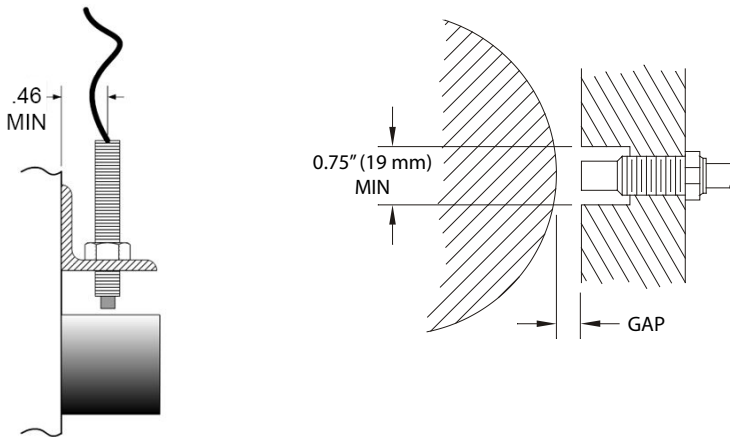

Figure 1: Clearance dimensions for standard 5mm and 8mm radial vibration measurements. (Tight View can be closer)

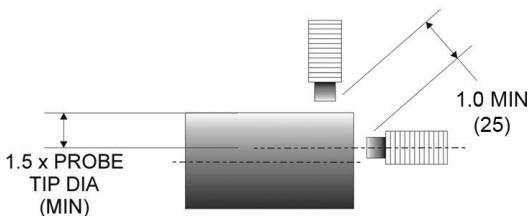

Figure 2: Minimum distance between probe tips. (Tight View can be closer)

### Thrust measurements

For thrust measurements ensure the thrust range is within the probe range. Move the machine to ensure the thrust range is set properly within the probe linear range.

For position (thrust) measurements, mount the probe with the probe axis parallel to the shaft and with the probe tip approximately 0.050" (1.25 mm) from the end of the shaft. For 11 mm diameter probes, this distance is approximately 0.088" (2.2mm). Provide the probe tip with sufficient clearance from surrounding metal to prevent an erroneous output. As a minimum, the clearance diameter should be 0.75" (19 mm) for the full length of the probe tip. For an 11mm probe, the minimum clearance should be 0.88" (22 mm). See Figure 1. You can set the probe gap "electrically" to the center of its measurement range by observing the DC output voltage at the BNC connector with an isolated meter. Adjust the probe gap to obtain -10 VDC, which corresponds to a gap of approximately 0.050" (1.25 mm). The preferred static gap range is 0.035" to 0.050" (0.8 to 1.25 mm). This corresponds to a gap voltage of -7.0 VDC to -10 VDC. Note that for 11 mm probes, the voltage is -9 VDC. To prevent cross-feed between two probes mounted in the same vicinity, maintain a minimum of 1.0" (25 mm) spacing between the probe tips. For 11 mm probes, this distance is approximately 1.5" (38mm). See Figure 3.

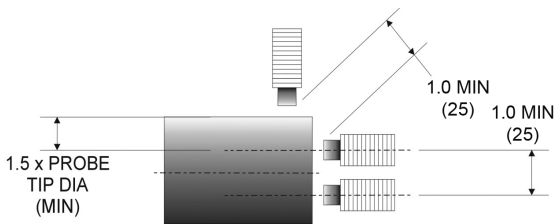

Figure 3: Key dimensions for thrust measurements

### Speed measurements

For RPM measurements, mount the probe with its axis radial to the shaft with its tip approximately 0.050" (1.25 mm) from the outermost surface of the shaft. The probe tip must be provided with sufficient clearance from surrounding metal to prevent an erroneous output. As a minimum, the clearance diameter should be 0.75" (19 mm) for the full length of the probe tip. See Figure 4. For the exact gapping procedure, see the section concerning calibration. To prevent cross-feed between two probes mounted in the same vicinity, at least 1.0" (25 mm) spacing between the probe tips should be maintained. See Figures 5, 6.

The minimum keyway depth is 0.060" (1.5 mm). The minimum keyway width and key width is the diameter of the probe tip (Figure 7). These minimums will ensure that the transmitter or driver responds properly to the keyway at all RPMs. Some experimentation may be required such as adjusting the probe gap or modifying the keyway dimensions.

The probe can be mounted in a simple bracket, such as the Metrix Model 7646, in a tapped hole in the bearing cap or by means of a Metrix Model 5497PM or 5499 Probe Housing. The latter arrangement provides an easy way to adjust the probe air gap, especially where the target is some distance from the outside surface of the machine.

When inserting the probe through the machine case or bearing cap, the signal voltage may vary widely before the proper gap is obtained. Therefore, be sure the gap is within 0.07" (1.8 mm) of the target before attempting to set the gap electrically. If possible, set the probe gap while the machine is shutdown, to avoid the danger of damaging the probe in the event that it touches the shaft.

Connect the probe to the transmitter using the proper extension cable such that the combined system length of probe + cable matches the transmitter configuration (refer to Metrix datasheet 1028003, ordering option B). Do not change the length of the extension cable from the system, as such action will adversely affect the calibration and linearity. If a connector must be replaced, the overall length of the cable can be reduced by 2" without harm. Insulate the probe connector / extension cable connector junction with the Metrix Model 8973 connector insulator.

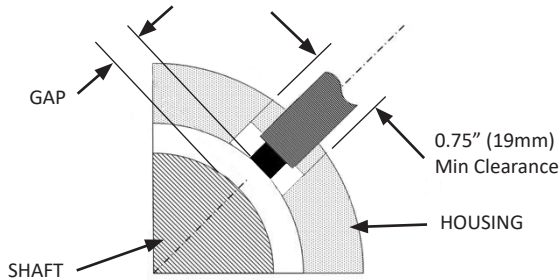

Figure 4

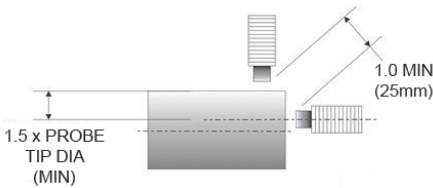

Figure 5

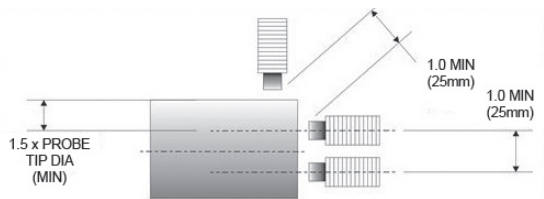

Figure 6

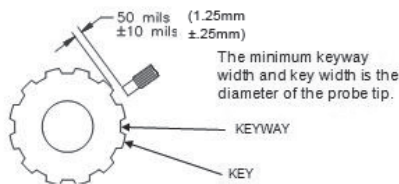

Figure 7

## Extension Cable Installation

Route the extension cable using the following guidelines:

- Check that the Driver/Transmitter, extension cable, and probe belong to the same system (e.g. MX8030 or MX2030 series) and that the total system length is correct (5m or 9m).
- Secure the extension cable to supporting surfaces or places in conduit. Make certain the cable is not kinked, scraped, nor bent beyond the minimum recommended radius of 1".
- Secure coaxial connectors between the extension cable and the proximity probe. Connection should be "finger tight" with an additional quarter turn using an open ended 9/32" wrench or equivalent.
- Insulate the connection between the probe lead and the extension cable by wrapping the connector with Teflon tape and the Metrix 8973 connector insulator. Avoid electrical tape for insulation because of its tendency to melt and detach over time.

## Driver / Transmitter Installation

Mount the driver or transmitter in a suitable enclosure in a location that is compatible with its environmental specifications. Refer to the datasheet for the environmental specifications. The driver or transmitter comes as a DIN rail mount. The below figure shows the unit with the optional flat base mounting plate, Metrix part number 9647. The 9647 mounting plate has two different hole patterns. One is for MX2033/MX2034 transmitters and the other pattern is for Metrix 5533, MX3300 and most other manufacturers' probe drivers.

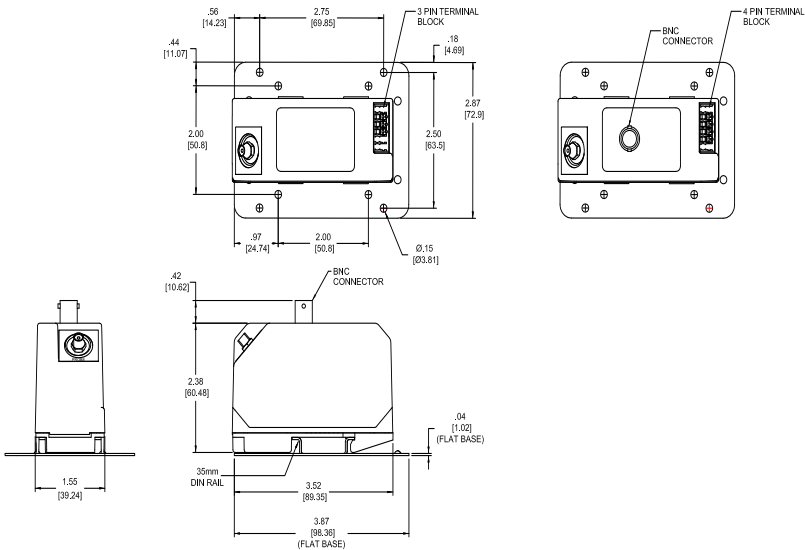
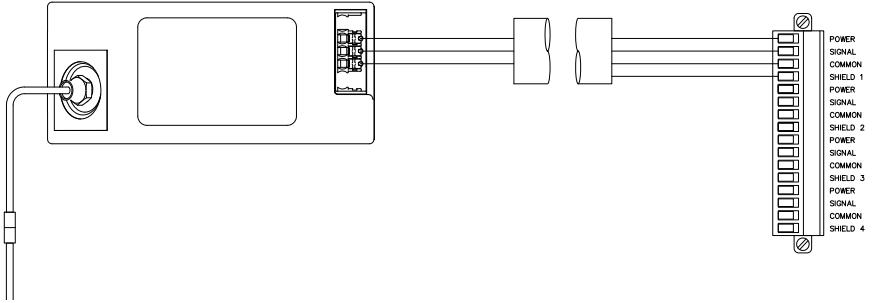

Figure 8: Key dimensions for flat base installation.

### MX2033 Field Wiring Installation

The driver circuit is insulated from ground by its plastic housing. If grounding of the driver is required, a jumper wire can be used to connect the COM terminal to one of the mounting screws. Proper attention must be given to other connections in the circuit to prevent unwanted ground loops which can cause improper operation.



### MX2034 Field Wiring Installation

You can wire the MX2034 transmitter with one or multiple receivers as shown in Figure 9 or Figure 10.

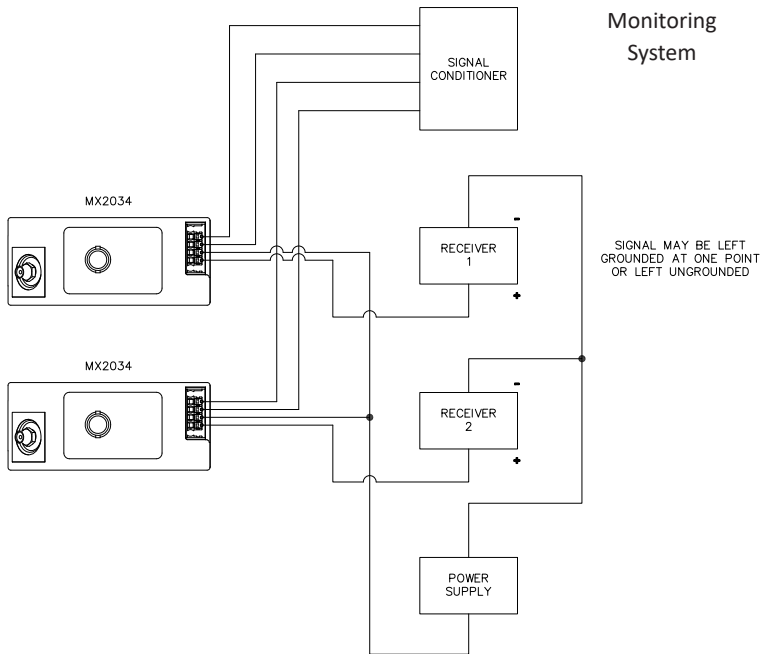

Figure 9: MX2034 wiring with individual receivers



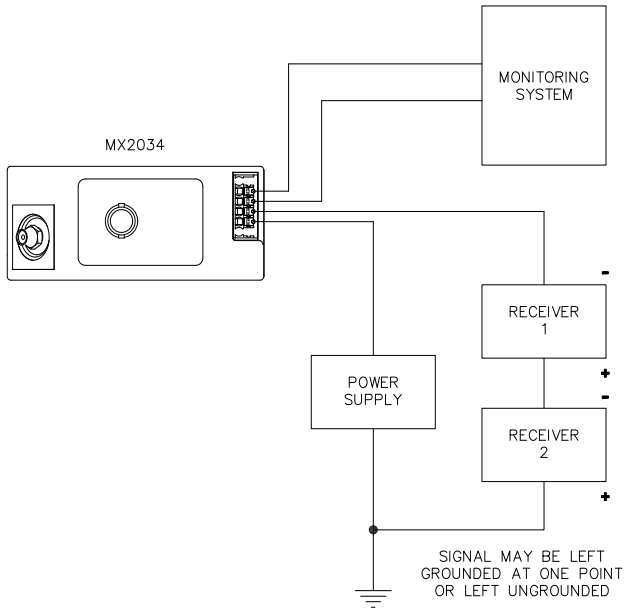
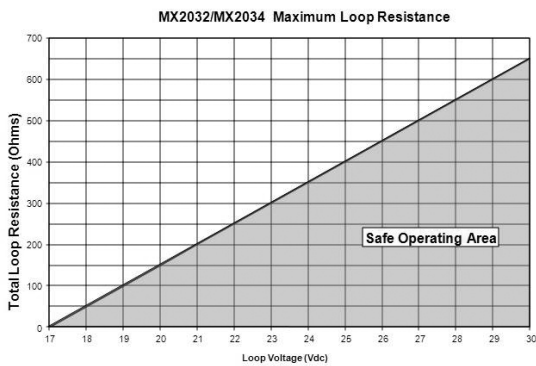

Figure 10: MX2034 wiring with multiple receivers

Connect the field wiring (16 to 22AWG) in accordance with the appropriate diagrams. For the MX2034, the minimum power supply voltage is 17 V plus 1 volt for each 50  $\Omega$  of loop resistance. See Graph 1.



## **HAZARDOUS AREA INSTALLATIONS**

### **MX2034 (DPS) General Requirements**

Connect the field wiring in accordance with Metrix drawing 100508 for ATEX installations and 100506 for North American installations.



Baseefa 05ATEX0195X  
II 1G Ex ia IIC T4  
(-40°C < Tamb < 85°C)



Exia; Intrinsically Safe  
Class I, Div. 1, Groups A, B, C, D  
Temp Code T4 (-40°C ≤ Ta ≤ +85°C)

### **SPECIAL CONDITIONS OF SAFE USE**

Mount the DPS in a separate enclosure capable of withstanding a 7 joule impact and providing a minimum ingress protection of IP54.

Consider that the DPS is not capable of withstanding the insulator test required by Clause 6.4.12 of EN50020:2002 when installing the DPS.

The DPS cannot be repaired in the field. Replace a failed DPS with an equivalent unit.

Do not expose the DPS to dust conditions.

Do not install the DPS where it may be subjected to mechanical and excessive thermal stresses or where it may be attacked by existing or foreseeable aggressive substances.

Install the DPS such that its terminals are protected to at least IP20.

Protect the plastic DPS enclosure from impact and friction.

Perform a risk assessment in accordance with Clause 10 of EN60079-25 and install lightning protection arresters as deemed necessary.

**WARNING – SUBSTITUTION OF COMPONENTS MAY IMPAIR INTRINSIC SAFETY. AVERTISSEMENT: LA SUBSTITUTION DE COMPOSANTS PEUT COMPROMETTRE LA SECURITE INTRINSEQUE.**

**WARNING – TO PREVENT IGNITION OF FLAMMABLE OR COMBUSTIBLE ATMOSPHERES, DISCONNECT POWER BEFORE SERVICING.**

**WARNING – TO PREVENT IGNITION OF FLAMMABLE OR COMBUSTIBLE ATMOSPHERES, READ, UNDERSTAND, AND ADHERE TO THE MANUFACTURER'S LIVE MAINTENANCE PROCEDURES.**

### Intrinsically Safe Installation in Hazardous Environments

The driver requires a minimum of 17 VDC for proper operation. The voltage drop across the specified zener barriers on the installation drawings with a 20 mA loop current is 8.1 VDC. The minimum loop power supply voltage required is 25.1 VDC plus 1 volt for each 50 Ω of loop resistance. The maximum loop power supply voltage that may be applied to the safety barrier is 26 VDC. Therefore, the maximum loop resistance with a 26 VDC supply is 45 Ω.

Example: Single wire resistance = 5 Ω

Resistance of receiver = 50 Ω

Total loop resistance = 55 Ω

Minimum supply voltage = 55 Ω (1VDC/50 Ω) + 25.1 VDC = 26.2 VDC

Permanent wiring connection to the Dynamic Signal terminal or BNC connector is not allowed under the intrinsic safety certification requirements. Table 1 lists recommended zener barriers. Other barrier manufacturers can be used as long as they meet the required parameters noted on the installation drawings.

DPS Model	MTL Barrier Model
MX2034	MTL 787(+) or equivalent

Table 1: Recommended Barriers

### INPUT/OUTPUT PARAMETERS

Power Terminal Entity Parameters	
$U_i$	28V
$I_i$	93mA
$P_i$	0.66W
$C_i$	18nF
$L_i$	0

Table 2: Power Terminal Entity Parameters

ATEX Parameters	
$U_o$	5.36V
$I_o$	3.64mA
$P_o$	20mW
$C_i$	24nF
$L_i$	110μH
$C_o$	32μF
$L_o$	500μH
$L_o/R_o$	> 1000μH/Ω

Table 3: Probe Connector ATEX Entity Parameters

UL/CSA Parameters	
$V_{oc}$	= 5.36V
$I_{oc}$	= 93mA
$C_a$	= 62μF
$L_a$	= 8.5mH
$P_o$	= 0.5W

Table 4: Probe Connector UL/CSA Entity Parameters

## Installation in Zone 2 and Div. 2 Areas

### Zone 2 Area

Baseefa 06ATEX0113X Ex nA IIC T4 ( $-40^{\circ}\text{C} \leq T_a \leq +85^{\circ}\text{C}$ )

#### SPECIAL CONDITIONS OF SAFE USE:

Connect the field wiring in accordance with Metrix drawing 100515.

When the DPS is being used in accordance with the type of protection: Ex nA IIC T4 ( $-40^{\circ}\text{C} \leq T_a \leq +85^{\circ}\text{C}$ ), the apparatus must be mounted in an enclosure capable of withstanding a 7 joule impact (at  $-40^{\circ}\text{C}$  if non-metallic) and provide a degree of ingress protection of at least IP54.

The DPS is certified as a component only and must be installed in a suitable enclosure acceptable to local authorities.

Field wiring from the safe area to the transmitter must conform with the local electrical code. The transmitter provides a non-incendive circuit to probe and extension cable, which therefore require no further electrical protection.

Do not use Dynamic Signal BNC connector or terminal unless area is known to be non-hazardous.

Transmitter is certified as a component only and must be installed in a suitable enclosure acceptable to local authorities.

The driver is not capable of withstanding the insulator test required by Clause 6.4.12 of EN50020:2002. This must be taken into account when installing the driver.

### Div. 2 Area

Class I Division 2 Hazardous Locations (Non-Incendive), when installed per drawing 100512. THIS EQUIPMENT IS SUITABLE FOR USE IN CLASS I, DIVISION 2, GROUPS A, B, C, D OR NON-HAZARDOUS LOCATIONS ONLY.

WARNING - EXPLOSION HAZARD – SUBSTITUTION OF COMPONENTS MAY IMPAIR SUITABILITY FOR CLASS I, DIVISION 2.

AVERTISSEMENT - RISQUE D'EXPLOSION – LA SUBSTITUTION D'E COMPOSANTSP EUTR ENDRE CE MATERIEL INACCEPTABLE POUR LES EMBLEMEMENTS DE CLASSE I, DIVISION 2.

## MX2033 Intrinsically Safe Installation in Hazardous Environments



Baseefa 05ATEX0195X  
II 1G Ex ia IIC T4  
( $-40^{\circ}\text{C} < T_{amb} < 85^{\circ}\text{C}$ )



Exia; Intrinsically Safe  
Class I, Div. 1, Groups A, B, C, D  
Temp Code T4 ( $-40^{\circ}\text{C} \leq T_a \leq +85^{\circ}\text{C}$ )

Connect the field wiring in accordance with Metrix drawing 100509 for ATEX installations and 100506 for UL/CSA installations. The driver requires a minimum of 17 VDC for proper operation. The voltage drop across the specified zener barriers on the installation drawings with a 10 mA supply current is 4.1 VDC. The minimum loop power supply voltage required is 25.1 VDC plus 1 volt for each 50  $\Omega$  of loop resistance. The maximum loop power supply voltage that may be applied to the safety barrier is 26 VDC. Therefore, the maximum loop resistance with a 26 VDC supply is 45  $\Omega$ .

Example: Single wire resistance = 5 Ω  
 Resistance of receiver = 50 Ω  
 Total loop resistance = 55 Ω  
 Minimum supply voltage = 55 Ω (1 VDC/50 Ω) + 25.1 VDC = 26.2 VDC

**SPECIAL CONDITIONS OF SAFE USE:**

The apparatus must be mounted within a separate enclosure capable of withstanding a 7 joule impact and providing a minimum ingress protection of IP54.

The transmitter is not capable of withstanding the insulator test required by Clause 6.4.12 of EN50020:2002. This must be taken into account when installing the driver.

The driver cannot be repaired in the field and must be replaced by an equivalent unit. The driver is not to be exposed to dust conditions.

The driver should not be installed where it may be subjected to mechanical and excessive thermal stresses or where it may be attacked by existing or foreseeable aggressive substances.

The apparatus enclosure is made from plastic which must be protected from impact and friction.

Installer must perform a risk assessment in accordance with Clause 10 of EN60079-25 and install lightning protection arresters as deemed necessary.

WARNING – SUBSTITUTION OF COMPONENTS MAY IMPAIR INTRINSIC SAFETY.

AVERTISSEMENT: LA SUBSTITUTION DE COMPOSANTS PEUT COMPROMETTRE LA SECURITE INTRINSEQCJE.

WARNING – TO PREVENT IGNITION OF FLAMMABLE OR COMBUSTIBLE ATMOSPHERES, DISCONNECT POWER BEFORE SERVICING.

WARNING – TO PREVENT IGNITION OF FLAMMABLE OR COMBUSTIBLE ATMOSPHERES, READ, UNDERSTAND, AND ADHERE TO THE MANUFACTURER’S LIVE MAINTENANCE PROCEDURES.

**INPUT/OUTPUT PARAMETERS**

Power Terminal Entity Parameters	
U <sub>i</sub>	30V
I <sub>i</sub>	101mA
P <sub>i</sub>	0.915W
C <sub>i</sub>	17.6nF
L <sub>i</sub>	110μH

Table 5: Power Terminal Entity Parameters.

ATEX Parameters	
U <sub>o</sub>	5.36V
I <sub>o</sub>	3.64mA
P <sub>o</sub>	20mW
C <sub>i</sub>	24nF
L <sub>i</sub>	110μH
C <sub>o</sub>	32μF
L <sub>o</sub>	500μH
L <sub>c</sub> /R <sub>o</sub>	> 1000μ/H/Ω

Table 6: Probe Connector ATEX Entity Parameters.

UL/CSA Parameters	
V <sub>oc</sub>	= 5.36V
I <sub>oc</sub>	= 93mA
C <sub>a</sub>	= 62μF
L <sub>a</sub>	= 8.5mH
P <sub>o</sub>	= 0.5W

Table 7: Probe Connector Intertek Entity Parameters.

Table 8 lists recommended zener barriers. Other barrier manufacturers can be used as long as they meet the required parameters noted on the installation drawings.

DPS Model	MTL Barrier Model
MX2033	MTL 796(-) or equivalent

Table 8: Recommended Barriers.

## Installation in Zone 2 and Div. 2 Areas

### Zone 2 Area

Baseefa 06ATEX0113X Ex nA IIC T4 ( $-40^{\circ}\text{C} \leq T_a \leq +85^{\circ}\text{C}$ )

#### SPECIAL CONDITIONS OF SAFE USE:

Connect the field wiring in accordance with Metrix drawing 1113106.

When the apparatus is being used in accordance with the type of protection: Ex nA IIC T4 ( $-40^{\circ}\text{C} \leq T_a \leq +85^{\circ}\text{C}$ ), the apparatus must be mounted in an enclosure capable of withstanding a 7 joule impact (at  $-40^{\circ}\text{C}$  if non-metallic) and provide a degree of ingress protection of at least IP54.

Driver is certified as a component only and must be installed in a suitable enclosure acceptable to local authorities.

Field wiring from the safe area to the transmitter must conform with the local electrical code.

The transmitter provides a non-incendive circuit to probe and extension cable, which therefore require no further electrical protection.

The driver is not capable of withstanding the insulator test required by Clause 6.4.12 of EN50020:2002. This must be taken into account when installing the driver.

### Div. 2 Area

Class I Division 2 Hazardous Locations (Non-Incendive), when installed per drawing 100512, sheet 2.

THIS EQUIPMENT IS SUITABLE FOR USE IN CLASS I, DIVISION 2, GROUPS A,B, C, D OR NON-HAZARDOUS LOCATIONS ONLY.

WARNING - EXPLOSION HAZARD – SUBSTITUTION OF COMPONENTS MAY IMPAIR SUITABILITY FOR CLASS I, DIVISION 2.

AVERTISSEMENT - RISQUE D'EXPLOSION – LA SUBSTITUTION D'ECOMPOSANTSP EUTR ENDRE CE MATERIEL INACCEPTABLE POUR LES EMPLACEMENTS DE CLASSE I, DIVISION 2.

## CALIBRATION AND SIGNAL ANALYSIS

### General

Factory calibrated units are for use with the specified probe, extension cable and target part numbers. Use the User configuration software (see section 0) to configure un-configured units before putting into service. For maximum accuracy, calibrate the driver with the probe and cable to be used.



**CAUTION:** Do not connect test equipment or cables to the driver unless the area has been determined to be non-hazardous.

## ENVIRONMENTAL INFORMATION



This electronic equipment was manufactured according to high quality standards to ensure safe and reliable operation when used as intended. Due to its nature, this equipment may contain small quantities of substances known to be hazardous to the environment or to human health if released into the environment. For this reason, Waste Electrical and Electronic Equipment (commonly known as WEEE) should never be disposed of in the public waste stream. The “Crossed-Out Waste Bin” label affixed to this product is a reminder to dispose of this product in accordance with local WEEE regulations. If you have questions about the disposal process, please contact Metrix Customer Services.

All trademarks, service marks, and/or registered trademarks used in this document belong to Metrix Instrument Company, L.P. except as noted below:

Teflon® is a mark of DuPont in the United States and other countries.

© 2019, Metrix Instrument Company, L.P. All rights reserved.

info@metrixvibration.com  
www.metrixvibration.com  
8824 Fallbrook Dr. Houston, TX 77064, USA  
Tel: 1.281.940.1802 • Fax: 1.713.559.9421  
After Hours (CST) Technical Assistance: 1.713.452.9703