

5550 & 5550G Mechanical Vibration Switches

SAFETY MANUAL

TABLE OF CONTENTS

1.	PURPOSE.....	3
1.1.	DISCLAIMER AND WARNING	3
2.	SYMBOLS USED IN THIS MANUAL.....	3
3.	REQUIRED SKILLS AND QUALIFICATIONS.....	4
4.	TERMS, DEFINITIONS AND ABBREVIATIONS.....	5
4.1.	TERMS AND DEFINITIONS.....	5
4.2.	ACRONYMS AND ABBREVIATIONS.....	7
5.	REFERENCE DOCUMENTS AND STANDARDS	8
6.	PRODUCTS INTRODUCTION.....	9
6.1.	PRODUCTS FAMILY IDENTIFICATION	10
6.2.	SPECIFICATIONS.....	11
7.	RELIABILITY AND SAFETY CHARACTERISTICS	13
7.1.	MICROSWITCH CONTACTS	14
7.2.	MICROSWITCH REDUNDANCY.....	14
7.3.	THERMISTOR CONSIDERATIONS.....	15
7.4.	RELIABILITY DATA	15
7.5.	SYSTEMATIC CAPABILITY	17
7.6.	RANDOM SAFETY INTEGRITY.....	17
7.7.	HARDWARE SAFETY INTEGRITY	20
8.	REQUIREMENTS FOR IMPLEMENTATION INTO A SIS	21
9.	PROOF TEST	22

1. PURPOSE

The purpose of this safety manual is to document all the information specifically related to the safety aspect of the Metrix 5550 & 5550G Mechanical Vibration Switches. These devices are certified for use as components in a functional safety system. This safety manual is then required in order to enable the integration of the devices into a safety related system with the objective to be in compliance with the requirements of the IEC 61508-2 Annex D.

The information contained in this Safety Manual are valid for the models indicated in paragraph 6.

When the Mechanical Vibration Switch is included in a Safety Instrumented Function, the integrator shall evaluate the performance of the device into the SIF loop, in order to ensure its proper implementation.

The instructions and information contained in this manual are valid only for the Mechanical Vibration Switch, in case of integration in a Safety Instrumented System, the Logic Solver and Final Element information will be provided by the specifics safety manuals.

1.1. DISCLAIMER AND WARNING

By using this product, you hereby signify that you have read this disclaimer and warning carefully and that you understand and agree to abide by the terms and conditions herein. Integrating this device into a safety instrumented system, you agree that you are solely responsible for your own conduct while using this product, and for any consequences thereof. You agree to use this product only for purposes that are proper and in accordance with all applicable laws, rules, and regulations, and all terms, safety prescriptions and precautions, practices, policies and all additional revisions or guidelines that METRIX has made and may make available.

2. SYMBOLS USED IN THIS MANUAL

This manual contains some symbols that are used to focus the user's attention on safety-related aspects. The following symbols are used:



WARNING!

This symbol identifies instructions that must be respected in order to avoid damages to things or to the personnel involved during the use of the SIS.



CAUTION

This symbol identifies instructions that must be followed to avoid malfunctioning of the SIS.



IMPORTANT

This symbol identifies important information that are necessary to understand the meaning of an operation or an activity.



WARNING!

Read the safety manual to become familiar with the features of this product before operating. Failure to operate the product correctly can result in damage to the product, personal property, and cause serious injury. This is a sophisticated safety-related product. It must be operated with caution and common sense and requires some basic mechanical ability. Failure to operate this product in a safe and responsible manner could result in injury or damage to the product, compromise the overall safety of the equipment under control or other property. This product is not intended for use by not functional safety qualified and properly trained personnel. Do not use with incompatible components or alter this product in any way outside of the documents provided by METRIX Instruments Co.

3. REQUIRED SKILLS AND QUALIFICATIONS

This manual is addressed to qualified personnel authorized for installation, operation and maintenance of Metrix 5550 & 5550G Mechanical Vibration Switches. As required by the IEC 61508-1 the appropriateness of competence shall be considered taking into account all relevant factors including safety engineering knowledge appropriate to the technology, knowledge of safety regulatory framework and previous experience.



IMPORTANT

In case of unqualified interventions, or if the advice of this manual is neglected, causing disturbances of safety functions, personal injuries, property or environmental damages may occur for which Metrix Instrument Co. cannot take liability.

4. TERMS, DEFINITIONS AND ABBREVIATIONS

4.1. TERMS AND DEFINITIONS

Architecture

Arrangement of hardware and/or software elements in a system.

Architectural constraint

This reports the maximum SIL achievable based on the SIF's subsystems architecture alone. This is calculated solely on the basis of Type A or Type B device selection, redundancy (hardware fault tolerance), and the safe failure fraction (calculated or conservatively assumed if no data is provided). It does not pertain to Systematic Capability or certification. This is calculated as indicated, using respective IEC 61508 or IEC 61511 tables.

Architectural Type

- Type A equipment or (sub)system: "Non –complex" (sub)system or equipment according 7.4.3.1.2 of IEC 61508-2;
- Type B equipment or (sub)system: "Complex" (sub)system or equipment according 7.4.3.1.3 of IEC 61508-2.

Diagnostic Coverage

Fraction of dangerous failures rates detected by diagnostics. Diagnostics coverage does not include any faults detected by proof tests.

Mean Repair Time

Expected overall repair time

Mean Time to Restoration

Expected time to achieve restoration.

Mode of operation

Way in which a SIF operates which may be either low demand mode, high demand mode or continuous mode:

- Low Demand Mode: mode of operation where the SIF is only performed on demand, in order to transfer the process into a specified safe state, and where the frequency of demands is no greater than one per year;
- High Demand Mode: mode of operation where the SIF, is only performed on demand, in order to transfer the process into a specified safe state, and where the frequency of demands is greater than one per year;
- Continuous Mode: where the mode of operation where the SIF retains the process in a safe state as part of normal operation.

Mo0N

SIS, or part thereof, made up of "N" independent channels, which are so connected, that "M" channels are sufficient to perform the SIF.

Hardware Fault Tolerance

A hardware Fault Tolerance of N means that N+1 is the minimum number of faults that could cause a loss of the safety function. In determining the hardware fault tolerance no account shall be taken of other measures that may control the effects of faults such as diagnostics.

Probability of dangerous Failure on demand PFD

Average probability of dangerous failure on demand.

Probability of dangerous Failure per Hour PFH

Average probability of dangerous failure within 1 h.

Proof Test

Periodic test performed to detect dangerous hidden faults in a SIS so that, if necessary, a repair can restore the system to an “as new” condition or a close as practical to this condition.

Safe Failure Fraction

Property of a safety related element that is defined by the ratio of the average failure rates of safe plus dangerous detected failures and safe plus dangerous failures.

Safety instrumented function (SIF)

Safety Function to be implemented by a safety instrumented system (SIS)

Safety instrumented system (SIS)

Instrument system used to implement one or more SIFs.

Safety Integrity

Ability of the SIS to perform the required SIF as and when required.

Safety Integrity Level (SIL)

Discrete level (one out of four) allocated to the SIF for specifying the safety integrity requirements to be achieved by the SIS.

Safe State

State of process when safety is achieved.

Systematic Capability

Measure (expressed on a scale of SC 1 to SC 4) of the confidence that the systematic safety integrity of a device meets the requirements of the specified SIL, in respect of the specified safety function, when the device is applied in accordance with the instructions specified in the device safety manual.

 λ

Failure rate (per hour) of a channel in a subsystem.

 λ_D

Dangerous failure rate (per hour) of a channel in a subsystem.

 λ_S

Safety failure rate (per hour) of a channel in a subsystem.

 λ_{DU}

Dangerous undetected failure rate (per hour) of a channel in a subsystem.

 λ_{DD}

Dangerous detected failure rate (per hour) of a channel in a subsystem.

functional safety

part of the overall safety relating to the EUC and the EUC control system that depends on the correct functioning of the E/E/PE safety-related systems and other risk reduction measures

safe state

state of the EUC when safety is achieved

4.2. ACRONYMS AND ABBREVIATIONS

BPCS	Basic Process Control System
DC	Diagnostic Coverage
E/E/PE	Electrical / Electronic / Programmable Electronic
EuC	Equipment Under Control
FIT	Failure In Time
HFT	Hardware Fault Tolerance
IEC	International Electro-Technical Commission
MRT	Mean Repair Time
MTTR	Mean Time to Restoration
PFD	Probability of Failure on Demand
PLC	Programmable Logic Controller
PTC	Proof Test Coverage
SC	Systematic Capability
SFF	Safe Failure Fraction
SIL	Safety Integrity Level
SIS	Safety Instrumented System

5. REFERENCE DOCUMENTS AND STANDARDS

The following table shows the Standards useful for the Safety Manual realization:

Doc ID	Standard Code	Standard title
[D1].	IEC 61508-1:2011-02	Functional safety of electrical/electronic/programmable electronic safety-related systems - Part 1: General requirements
[D2].	IEC 61508-2:2011-02	Functional safety of electrical/electronic/programmable electronic safety-related systems - Part 2: Requirements for electrical/electronic/programmable electronic safety-related systems
[D3].	IEC 61508-4:2011-02	Functional safety of electrical/electronic/programmable electronic safety-related systems - Part 4: Definitions and abbreviations
[D4].	IEC 61508-5:2011-02	Functional safety of electrical/electronic/programmable electronic safety related systems - Part 5: Examples of methods for the determination of safety integrity levels
[D5].	IEC 61508-6:2011-02	Functional safety of electrical/electronic/programmable electronic safety-related systems - Part 6: Guidelines on the application of IEC 61508-2 and IEC 61508-3
[D6].	IEC 61508-7:2011-02	Functional safety of electrical/electronic/programmable electronic safety-related systems - Part 7: Overview of techniques and measures

The following table shows the documents useful for the Safety Manual realization:

Doc ID	Project Document Name	Document Code	Version
[D7].	Datasheet	Doc# 1004461	May 2018-Rev V
[D8].	Installation Manual	Doc# 1231558	August 2018-Rev C
[D9].	SIL Certificate	MTXI-5550G-ENS-E01	July 2019-Rev A
[D10].	Safety Assessment Report		

6. PRODUCTS INTRODUCTION

5550 and 5550G mechanical vibration switches are designed for vibration protection in disaster recovery applications for low- to medium-speed machinery.

5550 and 5550G mechanical vibration switches offer protection against catastrophic vibrations, not precise measurement and fine tuning. The two units are identical internally and differ only in their enclosure style and external access to adjustments. The 5550G is used for hazardous areas applications requiring gas group IIC approvals but has no externally accessible adjustments. The 5550 has externally available setpoint adjustment and reset facilities and can be used for applications up to gas group IIB + hydrogen.

5550 and 5550G operating mechanism is purely mechanical and consists of a tension spring attached to a pivoting plate on an over-center fulcrum. Normally, this plate is in an untripped position. However, in the presence of seismic acceleration (whether vibratory or impact) along the switch's sensitive axis higher than the dangerous threshold, the trip plate will pivot beyond this over-center position, snapping to a stable tripped position where it contacts an internal micro-switch relay, changing the state of the relay. The switch therefore allows automatic machinery shutdown/trip if properly integrated in a Safety Instrumented System (SIS).

Once the switch has assumed its tripped position, it must be reset manually by means of the external reset plunger (5550 only), or by means of a remote electrical reset (standard on 5550G, optional on 5550). The remote reset capability can also be used as a startup delay to hold the switch in an untripped state for as long as coil excitation is supplied, up to 30 seconds (the maximum duration is governed by a non-adjustable, factory-installed thermistor circuit). The startup delay feature is useful during machinery startup when vibration in excess of the normal trip setting may be temporarily incurred.

The clockwise rotation of the adjusting shaft allows setpoint selection (the dangerous vibrations threshold that triggers device trip). A single set of silver-plated SPDT relay contacts are provided, in order to connect the mechanical vibration switch to a machine control system. An option for DPDT contacts is also available, and for extremely corrosive environments, gold-plated relay contacts may be ordered. The housing is weatherproof with an optional hazardous area rating. Model 5550G uses identical electrical mechanisms but carries an IECX rating ideal for IIC gas group applications.



Model 5550



Model 5550G

6.1. PRODUCTS FAMILY IDENTIFICATION

This Safety Manual is valid for each product listed in this paragraph.

5550 Mechanical Vibration Switch 5550- A B C - D E F □□□-□□□	
A	Hazardous Area Rating
0	None ⁵
1	UL US/CA Explosion Proof ² Class I, Div 1, Groups C,D Class II, Div 1, Groups E,F,G
2	UL US/CA Explosion Proof ² Class I, Div 1, Groups B,C,D Class II, Div 1, Groups E,F,G
3	OBSOLETE, specify A=4 instead ⁷
4	ATEX/IECEX Flameproof Ex d IIB+H2 T6 Gb Ex tb IIIC T85°C Db Ta -40°C to +70°C IP66
5	OBSOLETE, same as A=0 but B=3 or 4 for gold contacts
6	OBSOLETE, same as A=1 but B=3 or 4 for gold contacts
7	OBSOLETE, same as A=2 but B=3 or 4 for gold contacts
8	OBSOLETE, specify A=9 instead ⁷
9	OBSOLETE, same as A=4 but B=3 or 4 for gold contacts
10	OBSOLETE, specify A=11 instead ⁷
11	INMETRO Flameproof, Ex d IIB + H2 T6 Gb ¹ Ex tb IIIC T85°C Db Ta -40°C to +70°C IP66
A	EAC Flameproof, 1Ex d IIB + H2 T6 Gb Ta -40°C to +70°C
B	Relay Contacts
1	SPDT, Silver, 15A ¹
2	DPDT, Silver, 15A ¹
3	SPDT, Gold, 1A
4	DPDT, Gold, 1A
C	Reset / Startup Delay Coil Holding Strength⁶
1	5g
2	2g ³
3	10g
D	Reset / Startup Delay Coil Voltage
0	None ^{5,6}
1	115 Vac
2	230 Vac
3	24 Vdc ³
4	115 Vdc
E	Wiring Entry / Mounting Hole Pattern⁴
1	¾" NPT / Metrix 5173 or 5175
2	¾" NPT / Metrix 5097, VS-2 EX, or 366
3	¾" NPT / Metrix 5078 or 365
4	M20 x 1.5 / Metrix 5097, VS-2 EX, or 366 ²
6	M20 x 1.5 / Metrix 5173 or 5175 ²
7	¾" NPT / Metrix or PMC-BETA 440
8	M20 x 1.5 / Metrix 5078 or 365 ²
F	Environmental Rating
0	NEMA 4 / IP66 ⁵
1	NEMA 4X / IP66

5550G Mechanical Vibration Switch 5550- A B C - D E F □□□-□□□	
A	Hazardous Area Rating
G	ATEX / IECEx Flameproof Ex d IIC T6 Gb (Ta -40°C to +70°C) Ex tb IIIC T85°C Db Ta -40°C to +70°C IP66 EAC Flameproof 1Ex d IIC T6 Gb (Ta -40°C to +70°C)
B	Relay Contacts
1	SPDT, Silver, 15A
2	DPDT, Silver, 15A
3	SPDT, Gold, 1A
4	DPDT, Gold, 1A
C	Reset / Startup Delay Coil Holding Strength
1	5g
2	2g ³
3	10g
D	Reset / Startup Delay Coil Voltage
1	115 Vac
2	230 Vac
3	24 Vdc ³
4	115 Vdc
E	Wiring Entry / Mounting Hole Pattern⁸
9	¾" NPT (2 places)
F	Environmental Rating
2	IP66

NOTES:

- INMETRO approvals (A=11) available with silver relay contacts only (B=1 or B=2)
- UL US/CA approvals require tapered threads for conduit and are not compatible with option E=4, E=6, or E=8.
- When options C=2 and D=3 are simultaneously specified (2g, 24Vdc reset coil), the switch sensitive axis MUST be oriented vertically with the cover facing up. This coil lacks sufficient holding strength to support the trip plate when the switch is mounted horizontally or upside down. The switch may be mounted at any orientation for all other options.
- Consult datasheet for mounting plate dimensions corresponding to E options.
- If left blank, option 0 is provided.
- When D=0 (no reset /start-up delay coil), the C option is ignored regardless of which value is selected. All switches ship with a full-scale range of approximately 16gs.
- Options A=3, A=8, and A=10 were all for Ex d IIB T6 Gb. These are now replaced by the A=4, and A=11, respectively, which reflect the same approvals but with addition of the H2 gas group.
- Consult datasheet for mounting dimensions.

6.2. SPECIFICATIONS

	5550	5550G
Amplitude Range	0 to 16 g pk NOTE: Reset coil holding strength (option C) may limit the usable amplitude range of the switch when the startup delay feature is required.	0 to 16 g pk NOTE: Reset coil holding strength (option C) may limit the usable amplitude range of the switch when the startup delay feature is required.
Frequency Range	0 – 60 Hz (0 – 3600 rpm)	0 – 60 Hz (0 – 3600 rpm)
Setpoint Adjustment	Location: Externally Accessible Resolution: 1g (approximately 1/8th turn of adjustment screw where one full turn ≈ 8g) Range: 0 – 100% of amplitude range	Location: Internally Accessible (cover must be removed to access) Resolution: 1g (approximately 1/8th turn of adjustment screw where one full turn ≈ 8g) Range: 0 – 100% of amplitude range
Local reset	Manual plunger-style pushbutton on switch housing	Not available (must use remote electrical reset)
Temperature Limit	-40° C to +70° C (-40° F to +158° F)	-40° C to +70° C (-40° F to +158° F)
Mounting	4-hole rectangular	2-hole rectangular
Remote Electrical Reset / Startup Delay	Optional. Applying a momentary voltage to the reset terminals will reset the switch to its untripped position. Applying a persistent voltage to the reset terminals will suppress the trip mechanism from actuating for the duration of voltage application or 30 seconds, whichever is less (a thermistor circuit limits the maximum delay time).	Optional. Applying a momentary voltage to the reset terminals will reset the switch to its untripped position. Applying a persistent voltage to the reset terminals will suppress the trip mechanism from actuating for the duration of voltage application or 30 seconds, whichever is less (a thermistor circuit limits the maximum delay time).
Reset Coil Holding Strength	2g, 5g, or 10g. This option dictates the highest g-levels under which remote reset / startup delay capabilities will still operate.	2g, 5g, or 10g. This option dictates the highest g-levels under which remote reset / startup delay capabilities will still operate.
Enclosure Material	Copper-free cast aluminum (standard NEMA 4 version) Copper-free cast aluminum with clear epoxy coating (optional NEMA 4X version)	Cast aluminum with blue epoxy coating
Environment Rating	NEMA 4 / IP66 (standard) NEMA 4X / IP66 (optional)	NEMA 4 / IP66
Contacts	Type SPDT (standard), DPDT (optional) Plating Material Silver (standard), Gold (optional) Ratings Silver-plated 1A @ 125 Vac 1/4 hp @ 125 Vac 1/8 hp @ 250 Vac 0.5A @ 125 Vdc 0.25A @ 250 Vdc Gold-plated 15A @ 125-480 Vac	Type SPDT (standard), DPDT (optional) Plating Material Silver (standard), Gold (optional) Ratings Silver-plated 1A @ 125 Vac 1/4 hp @ 125 Vac 1/8 hp @ 250 Vac 0.5A @ 125 Vdc 0.25A @ 250 Vdc Gold-plated 15A @ 125-480 Vac



IMPORTANT

The information listed in the above table are extracted by datasheet 1004461 and shall be considered for reference only. In case of mismatch, the datasheet have the priority on the present table.

Depending on how the switch is oriented, gravity will act on the trip mechanism's movable mass to either add to or subtract from the spring force. For both model 5550 and 5550G switches, the switch orientation is the direction in which the cover faces. With the switch oriented horizontally, the effects of gravity will be negligible and only the spring force will govern the trip plate's behavior. With the switch oriented vertically up, gravity acts to keep the trip plate's movable mass in the untripped position, and inertial excitation must counteract both gravity and the spring force. With the switch oriented vertically down, gravity acts in the opposite direction and opposes the spring's force.



CAUTION

The device can be installed in each orientation, but depending on how the setpoint is adjusted, simply turning the switch on its side or upside down may be sufficient to cause it to trip, due to the effects of gravity.

7. RELIABILITY AND SAFETY CHARACTERISTICS

Safety Functions	Overall vibration protection input device for low to medium speed machinery.
Installation	Refer to [D8].
Lifetime	When using in the prescribed manner indicated in the [D8], the device can operate in safety applications up to 20 years.
Diagnostic	No internal diagnostics are present.
Interface	The 5550 and 5550G need no interface towards the SIS as the devices are certified for installation in hazardous areas.



WARNING!

Modification to the hardware are not permitted.



WARNING!

To avoid potential hazards, use this product only as specified. Only qualified personnel should perform installation, uninstallation and wiring procedures. If you suspect there is damage to this product, have it inspected by qualified personnel.



CAUTION

The housing of this product should be connected to earth ground. Before energizing the product, ensure its housing is properly grounded.



CAUTION

Do not touch exposed electrical connections and components when power is present.

7.1. MICROSWITCH CONTACTS

The 5550 and 5550G are equipped with a single or two microswitch depending on the configuration chosen during the device selection. Microswitch contacts that are suitable for safety applications (to trigger machinery trip/safe shutdown) are only the normally closed (NC), that are closed when untripped and open when tripped. The microswitch normally open (NO) contacts can be used only for annunciation functionalities, not functional safety related.

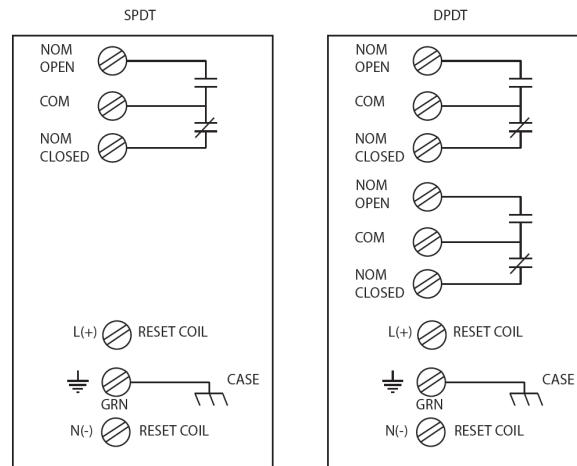

DPDT CONTACTS AND RESET COIL OPTION

7.2. MICROSWITCH REDUNDANCY

The mechanical vibration switch can be arranged in a configuration characterized by redundant microswitches to increase the overall reliability. The redundancy shall be implemented between the normally closed (NC) contacts of the two microswitches, that shall be wired in series (1oo2 voting: the opening of one contact is sufficient to trigger machinery trip). The series of the two NC contacts shall be wired to the Customer control system that controls the EUC. The two microswitches were previously proven through functional testing to be suitable for redundant configurations.



IMPORTANT

The 5550 and 5550G cannot be considered equipment able to reach the HFT=1 by them self even if the configuration with two microswitch has been chosen. The microswitches redundancy is anyway useful to increase the equipment overall reliability and shall be preferred.

7.3. THERMISTOR CONSIDERATIONS

The start-up delay feature is intended for use in machines that exhibit high vibration during start-up and works through use of an internal thermistor in series with a solenoid mechanism. When voltage is continuously applied, current flows in the circuit and the thermistor's temperature rises, gradually restricting current flow. When the current drops below the minimum value required to keep the coil energized, the solenoid retracts. Normally, it takes approximately 30 seconds for the thermistor to reach this "cut-off" temperature. However, several factors can serve to shorten or lengthen this interval as follows:

- **Ambient temperature:** the time for the thermistor to reach its cut-off value depends on the initial temperature of the thermistor. Likewise, if the switch is placed on a machine that can sustain a large temperature rise at the mounting location, the switch may be near its maximum temperature rating of 70°C after a period of prolonged operation. This will shorten the start-up delay interval when compared to operation on a "cold" machine.
- **Cool-Down period:** If the circuit activating the start-up delay leaves the voltage continuously applied (as is typical), the thermistor will remain hot until voltage is removed, such as following a machine trip. Thus, when the thermistor is not allowed to cool to its ambient surroundings, it will shorten the start-up delay.
- **Immediate restart:** If a restart is required immediately following a trip, the thermistor may be so hot that the switch cannot be immediately reset using the remote reset function. In such situations, it will be necessary to either manually reset the switch or wait for the thermistor to cool sufficiently.



WARNING!

To avoid potential malfunctioning due to device overuse, the conservative cool-down period of 10 minutes between two subsequent reset commands shall be guaranteed.



WARNING!

Voltages present at reset terminals can result in serious injury or death. Always de-energize these circuits prior to installation or maintenance and use appropriate lock-out / tag-out procedures where applicable.

7.4. RELIABILITY DATA

The reliability parameters have been obtained considering the Mechanical Vibration Switch as element of a safety-related system with the safety function: (s)

Overall vibration protection input device for low to medium speed machinery.



IMPORTANT

The design of each Safety Instrumented Function shall meet the requirements listed in the reference standards that shall be selected by taking into account the specific application.

The Mechanical Vibration Switches 5550 & 5550G are "last chance" devices to detect high acceleration values caused by the machine under control breakdown. The switch operating mechanism is designed to detect (displacements) movements related to high-amplitude low-frequency vibrations, rendering it suitable for low to medium speed machinery protection. When the machine under control failure results in structural vibrations that exceed the dangerous threshold, the mechanical switch intervention must result in the machine trip.

Since the switch is not able to detect high-frequency low-amplitude vibration, as they do not result in the plate trip, the device is suitable to applications as protection of cooling tower fans and mounted such that loss of a blade will result in significant structural acceleration at the switch mounting location. The switch may be used on other kind of machinery as well, if a difference in acceleration between normal and malfunction conditions exist at the device mounting location.



WARNING!

Mechanical Vibration Switches 5550 & 5550G are not measurement devices. The switches operating mechanism is designed to react to movements caused by high acceleration values.



WARNING!

Metrix Mechanical Vibration Switches are not intended for use on high-speed turbomachinery or on machines where changes in seismic acceleration smaller than 1G must be reliably detected.

Specific activities necessary to investigate and reach a judgment on the adequacy of the functional safety achieved by the E/E/PE safety-related system or compliant items (elements/subsystems) has been conducted by an independent assessor. The following tables show the safety parameters of the devices listed in paragraph 6.1. The first table refers to Mechanical Vibration Switch 5550, while the second one reports the Mechanical Vibration Switch 5550G reliability parameters. For a detailed explanation of the parameters meaning, application and associated assumptions refer to paragraphs 7.5-7.7.

Table 1 Reliability parameters for Mechanical Vibration Switch 5550 (a) and 5550G (b)

Mechanical Vibration Switch 5550					
Configuration	λ_{SU}	λ_{SD}	λ_{DU}	λ_{DD}	λ_{RES}
SPDT- Manual reset only	388	0	219	0	234
SPDT- Reset coil option	504	0	375	0	393
DPDT- Manual reset only (COMMON)	321	0	185	0	234
DPDT- Manual reset only (REDUNDANT SWITCH)	67	0	34	0	0
DPDT- Reset coil option (COMMON)	437	0	341	0	393
DPDT- Reset coil option (REDUNDANT SWITCH)	67	0	34	0	0
Systematic Capability (SC)	2(Route 1 _s)				
Hardware Safety Integrity	Type A		Route 1 _H		

Mechanical Vibration Switch 5550G					
Configuration	λ_{SU}	λ_{SD}	λ_{DU}	λ_{DD}	λ_{RES}
SPDT with Reset coil	473	0	290	0	309
DPDT with Reset coil (COMMON)	406	0	256	0	309
DPDT with Reset coil (REDUNDANT SWITCH)	67	0	34	0	0
Systematic Capability (SC)	2(Route 1 _s)				
Hardware Safety Integrity	Type A		Route 1 _H		

Note:

SPDT contacts are standard; DPDT contacts are optional. Reset coil is standard on 5550G, optional on 5550.

7.5. SYSTEMATIC CAPABILITY

Techniques and measures to control and avoid systematic failures during the different phases of the lifecycle have been evaluated and found to be sufficient to meet the requirements of SIL 2 in accordance to IEC 61508, Parts 1 - 7:2010. The compliance with the requirements has been achieved following the compliance Route 1_s.

The systematic capability provides a quantitative estimation of the robustness of the device against systematic failures resulting from design, project management and documentation quality. An appropriate group of techniques and measures to prevent the introduction of faults during the design and development phases are in place.

To control systematic faults the maintenance and test requirements formalized at design stage must be followed.

In order to preserve the systematic capability, the Mechanical Vibration Switch 5550 & 5550G must be used following the constraints reported in this manual in term of authorized personnel, installation, operating conditions and maintenance.



WARNING!

The declared systematic capability level is valid only if the requirements and limitations reported in this Safety Manual are fulfilled

7.6. RANDOM SAFETY INTEGRITY

The failure rates show in the previous tables are resulting from the FMEDA analysis, a FMEA extension that combines standard FMEA techniques with extension to identify online diagnostics techniques and the failure modes relevant to safety instrumented system design. The failure rates shall be used for the PFD_{AVG} estimation, taking into consideration all parameters such as redundancy, architectural constraints, diagnostic capability, also introduced by the whole system, including the considerations about the proof test and its effectiveness, mean time of restoration, up to the maintenance capability and its minimum characteristics.

The assumptions associated with these failure rates are as follows:

- Failure rates are constant, wear-out or infant mortality contributions are not included;
- The tabulated failure rates are in Failures in Time (FIT):

$$1 \text{ FIT} = [10^{-9} \text{ h}^{-1}]$$

The device total failure rate λ is given by $\lambda = \lambda_{SU} + \lambda_{SD} + \lambda_{DU} + \lambda_{DD} + \lambda_{RES}$.

The dangerous undetected failure rate λ_{DU} is due to faults that cause the failure of the safety function, as the mechanical vibration switch does not open the contacts when the structural acceleration reaches dangerous threshold. The high vibration level following machine failure is then not detected and the EUC could be seriously damaged.

The dangerous detected failure rate λ_{DD} value is 0, as no diagnostics on the switch internal operating mechanism are present.

The safe failure rate $\lambda_S = \lambda_{SU} + \lambda_{SD}$ represents failure of elements or subsystems that play a part in implementing the safety function, as they result in the spurious operation of the safety function or in the increase of the probability of spurious operation of the safety function to put the EUC (or part thereof) into a safe state or maintain a safe state;

The residual failure rate λ_{RES} includes the NO PART and NO EFFECT failure rates that is failure of a component that plays no part in implementing the safety function (NO PART) and failure of an element that plays a part in implementing the safety function but has no direct effect on the safety function (NO EFFECT).

The integration in the SIS, the whole SIS validation, and the PFD_{avg} calculation of the whole safety loop implementing the SIF is under end-user responsibility, together with the verification of the compliance with the allocated target SIL.

7.6.1. 5550 & 5550G- Configurations and Subsystem Functional Decomposition

The 5550 mechanical vibration switch was assessed including the following configurations:

- Single set of SPDT relay contacts with manual reset only (no redundancy);
- Single set of SPDT relay contacts with manual reset and electronic boards for remote reset activation (no redundancy);
- DPDT relay contacts with manual reset only (redundant micro-switches, 1oo2 configuration);
- DPDT relay contacts with manual reset and electronic boards for remote reset activation (redundant micro-switches, 1oo2 configuration).

The 5550G mechanical vibration switch was assessed including the following configurations:

- Single set of SPDT relay contacts with manual reset and electronic boards for remote reset activation (no redundancy);
- DPDT relay contacts with manual reset and electronic boards for remote reset activation (redundant microswitches, 1oo2 configuration).

All subcomponents of mechanical vibration switch have been considered as included in the common part, apart from the microswitches, analyzed as configurable with redundancy.

The failure rates reported are apportioned based on the previously listed configurations and split into common and redundant contributions, according to the same criteria.



Mechanical Vibration Switch COMMON PART	Mechanical Vibration Switch REDUNDANT PART
<ul style="list-style-type: none"> • Case • Armature Frame • Lever Mechanism • Setpoint Adjustment • Local Reset (standard) • Remote Reset (optional) 	<ul style="list-style-type: none"> • Micro-Switch (optional)

Note:
5550 Mechanical Vibration Switch decomposition;
Same decomposition is valid for 5550G model.



IMPORTANT

The failure rates of the redundant switch reported in Table 1 (both manual and remote reset configurations) refer to the SINGLE MICRO-SWITCH (1oo1 CONFIGURATION), not the complete 1oo2 redundant architecture.

To calculate the Mechanical Vibration Switches 5550 & 5550G with redundant micro-switch total PFH/PFD_{AVG}, end-user shall calculate PFH/PFD_{AVG} separately for the common (1oo1 architecture) and redundant (1oo2 architecture) parts and then sum the obtained values.

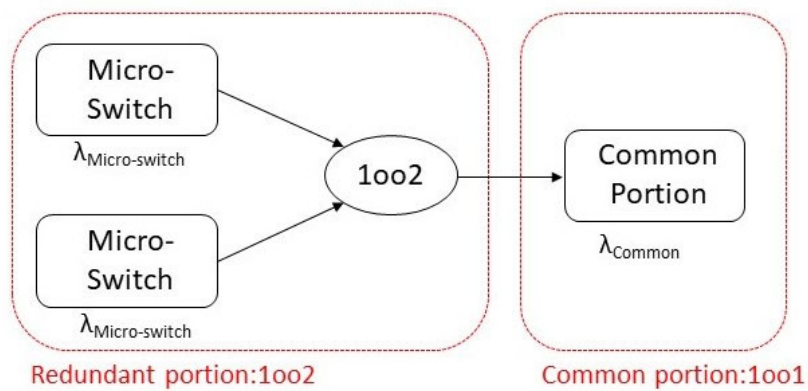

7.6.2. COMMON CAUSE FAILURES

Common Cause Failures (CCF) are dependent failures, consisting in multiple failures arising from a single shared cause. These are random and systematic events that cause multiple devices, systems or layers to fail simultaneously. All common cause failures have the potential to reduce the safety function performance.

Common cause failure rates estimation for mechanical vibration switch redundant part (microswitches) was carried out through the calculation of a value for β factor. The determination of common cause factors is based on the methods reported in IEC 61508-6, Annex D.

Since the reliability data declared in Table 1 are related to the microswitch in 1oo1 configuration, the contribution in case of redundant (1oo2) configuration has to be derived including the β factor in the calculation to take into account of common cause failures.

Equipment redundant components	β
Micro-switches	5%

7.7. HARDWARE SAFETY INTEGRITY

The constraints on hardware safety integrity have been verified in order to achieve a sufficiently robust architecture taking into account the level of element and subsystem complexity following the compliance route 1_H.

Route 1H is based on hardware fault tolerance and safe failure fraction concepts. According to Route 1H, in order to determine the maximum safety integrity level that can be claimed, the safe failure fraction shall be calculated for the item under analysis using the failure rate data.

The maximum allowable safety integrity level that can be claimed in terms of architectural constraints can be determined according to tables 2 and 3 (7.4.4.2 IEC 61508-2). Different tables are used if the element is classified as type A or B.

Mechanical Vibration Switches 5550 & 5550G have been classified as **type A** elements, following 7.4.4.1.2. IEC 61508-2 explanation.

An element can be regarded as type A if, for the components required to achieve the safety function:

- a) The failure modes of all constituent components are well defined; and
- b) The behavior of the component under fault conditions cannot be completely determined; or
- c) There is sufficient dependable failure data to show that the claimed rates of failure for detected and undetected dangerous failures are met.

8. REQUIREMENTS FOR IMPLEMENTATION INTO A SIS

Mechanical Vibration Switch shall be connected to a logic device that reads the switch contacts opening and takes the machine to trip status.

The switch must be correctly calibrated before installation, setting the needed setpoint, corresponding to the vibration dangerous threshold by rotating the adjusting shaft, as detailed in [D8].

The objective is to establish a setpoint as close as possible to normal operating conditions, while still allowing normal fluctuations without false trips. Establishing a setpoint that is too high may render machinery protection ineffective.



CAUTION

Turning the screw too far in the counterclockwise (CCW) direction will eventually pull the spring past the over-center location and cause the switch to snap into the tripped position without any external inertial excitation. When adjusted in this manner, the switch cannot be reset from its tripped position. Also, the nature of this over-center mechanism can cause it to be very unstable when adjusted too close to its equilibrium location, resulting in false trips.



CAUTION

The device must be rigidly attached to the machine so that it reflects machinery vibration, not vibration incurred by a loose mounting, an insufficiently stiff mounting bracket, or a bracket resonance.

9. PROOF TEST

The maximum proof test interval has been defined as 5 years. Mechanical Vibration Switches 5550 & 5550G shall be tested to verify that the correct functioning has not been compromised by the continuous exposition to vibration.



IMPORTANT

The proof test interval shall be chosen taking into consideration the main characteristics of each safety function where the switch is involved. This selection it's under the sole responsibility of who is in charge to implement the 5550 or 5550G into the SIS and shall not exceed the 5 years.

Description of the test

Proof test can be performed by inducing the proper acceleration to the switch, along its sensitive axis, with sufficient inertial force to exceed the its threshold response range. The test shall be carried out without remove the switch from the EuC and without modify the wiring connection or the control logic already implemented and tested during commissioning.

Verify the proper equipment response through the SIS logic solver.

Then, through the reset mechanism, restore the switch functionality. The reset functionality shall be tested by verifying if the reset input, or the manual mechanism, brings the plate back to its un-tripped position. The sequence trip-reset shall be repeated twice.

The test is considered as pass if the switch annunciates the threshold reached and the reset restores the switch functionality.

Additional equipment required to carried out the proof test: None.



WARNING!

Even if the proof test has been properly carried out, wrong or inappropriate maintenance may compromise the switch Follow the instruction listed into the user manual is mandatory to ensure the correct operability this equipment and consiquenty of the whole SIS.