

# Top mounting T20 and T21

Installation and Operating Manual



*Liquid*

*Level*

*Switches*

## UNPACKING

Top mounting liquid level switches are shipped from the factory with the float removed from the head assembly and packed separately in the same container. Unpack the instrument carefully. Make sure all components have been removed from the packing material. Inspect all components for damage. Report any concealed damage to the carrier within 24 hours. Check the contents of the packing slip and report any discrepancies to the factory. Check the nameplate model number to be sure it agrees with the packing slip and purchase order. Check and record the serial number for future reference when ordering parts.

Nameplate:  
- part number  
- serial n°

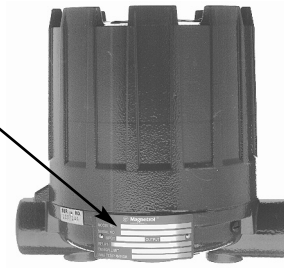

These units are in conformity with the provisions of:

1. Directive 2014/34/EU for equipment or protective system intended for use in potentially explosive atmospheres. EC-type examination certificate number ISSeP09ATEX024X (Ex d units) or KIWA18ATEX0022X (Ex i units).

**CAUTION: The float stem protruding from the head assembly is extremely fragile. DO NOT handle or place in a position such that any amount of force is placed on the stem. Proper operation of the control requires that the stem is not damaged or bent.**

## SPECIAL CONDITIONS FOR ATEX INTRINSICALLY SAFE USE

When the product is installed in an area requiring EPL Ga and the enclosure is made of aluminium, all precautions shall be taken in order to avoid all impacts or frictions which can result in the ignition of the potentially explosive atmosphere.

## INTRODUCTION

T20 and T21 units are simple, reliable float switches designed for top mounting to tanks or vessels. T20 units utilize a single switch mechanism and float. T21 tandem units utilize two switch mechanisms and two separate floats when widely spaced actuating levels are required. T20 and T21 tandem models are available for any type of open or closed vessel with either threaded or flanged type mounting and actuating depths up to 1219 mm (48 inches).

## PRINCIPLE OF OPERATION

The simple and foolproof operation of the top mounted float switches is illustrated in figures 1 and 2.

A permanent magnet ① is attached to a pivoted switch actuator and adjustment screw ②. As the float ③ rises following the liquid level, it raises the attraction sleeve ④ into the field of the magnet, which then snaps against the non-magnetic enclosing tube ⑤, actuating the switch ⑥. The enclosing tube provides a static pressure boundary between the switch mechanism and the process. On a falling level, an inconel spring retracts the magnet, deactivating the switch.

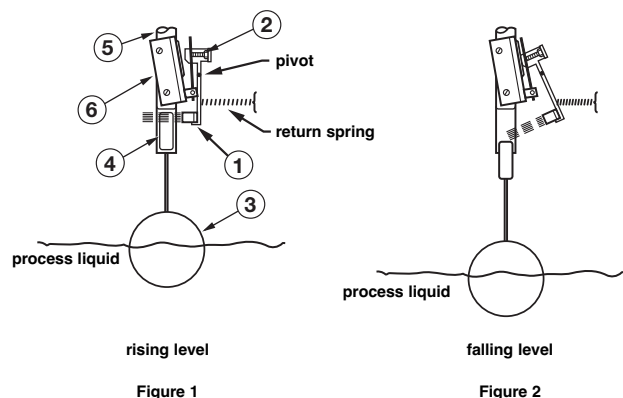

## MOUNTING

**CAUTION: Operation of all buoyancy type level devices should be done in such a way as to minimize the action of dynamic forces on the float. Good practice for reducing the likelihood of damage to the control is to equalize pressure across the device very slowly.**

Ensure that no tubes, rods, or other obstacles in the tank or vessel which could interfere with the operation of float(s).

Before assembling control to tank or vessel, check threaded or flanged mounting nozzle for the following:

- Nozzle length and inside diameter must be sized correctly to allow for switch actuation at design levels within the maximum differential available.

- Nozzle should be checked for horizontal alignment. Finished mounting must allow control switch housing to be within 3° degrees of vertical for proper operation. A three degree slant is noticeable by eye, but installation should be checked with a spirit level.

*NOTE: Do not insulate switch mechanism housing.*

## WIRING

**CAUTION: All units are shipped from the factory with the enclosing tube tightened and the switch housing set screw locked to the enclosing tube. Failure to loosen the set screw prior to repositioning the supply and output connections may cause the enclosing tube to loosen, resulting in possible leakage of the process liquid or vapor.**

*NOTE: If control is equipped with pneumatic switch mechanism, disregard these instruction and refer to instruction bulletin BE 42-685 and BE 42-686 on mechanism furnished for air (or gas) connections.*

The units are shipped with the cable entry of the switch housing placed 90° opposite the tank connections to simplify installation in most cases. If the location of the cable entry on the level switch is appropriate to the installation, proceed to Step 4 to begin wiring the unit. If another configuration is desired, the switch housing can be easily rotated by first following Steps 1, 2, and 3.

1. Loosen set screw(s) at base of switch housing. Refer to Figure 3.
2. Switch housing may be rotated 360° to allow correct positioning of cable entry.
3. Tighten set screw(s) at base of switch housing.
4. Unscrew and remove switch housing cover. The threads have been lubricated to facilitate removal.

**CAUTION: DO NOT attempt to unscrew cover of ATEX explosion proof housings before loosening locking screw in cover (Figure 3 - ATEX cast aluminium) or base (Figure 4 - ATEX cast iron) of housing. ALWAYS retighten locking screw after replacing cover.**

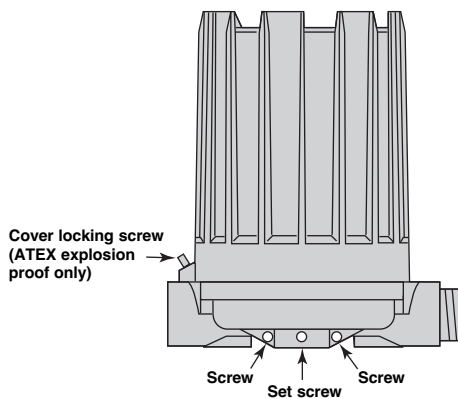

Figure 3  
Cast aluminium switch housing

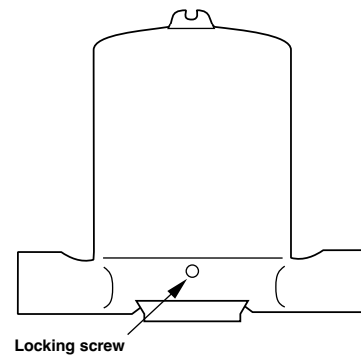

Figure 4  
ATEX cast iron switch housing

*NOTE: For supply connections use wire with a minimum rating of 75 °C, as required by process conditions. Use a minimum of 14 AWG wire for power and ground field wires. On high temperature applications (above 120 °C [250 °F] at mounting flange or bushing), high temperature wire should be used between control and first junction box located in a cooler area.*

5. The switch terminals are located next to the cable entry to facilitate wiring. Bring supply wires through cable entry. Route extra wire around enclosing tube under the baffle plate, and connect them to the proper terminals. Refer to the wiring diagram.
6. Dress wiring to ensure no interference or contact with the switch actuation arm, or replacement of switch housing cover.

*NOTE: Observe all applicable electrical codes and proper wiring procedures.*

Prevent moisture seepage into the enclosure by installing approved cable glands.

**CAUTION: For units with explosion proof housing, do not power the unit until the cable gland is sealed and the enclosure cover is screwed down securely.**

7. Replace housing cover and retighten locking screw in case of ATEX explosion proof housing.
8. Test switch action by varying liquid level in the tank or vessel. The upper switch on Model T21 units is actuated by movement of the lower float, while the lower switch is actuated by the upper float.

*NOTE: If switch mechanism fails to function properly, check vertical alignment of control housing and consult installation bulletin on switch mechanisms furnished.*

9. Check cover to base fit to be certain gasketed joint is tight. A positive seal is necessary to prevent infiltration of moisture laden air or corrosive gasses into switch housing.

For wiring diagrams, refer to the specific bulletin listed in the chart below:

Switch Series Letter	Description	Bulletin No.
B, C, D, F, O, Q, R, U, W, X, 8, 9	Dry Contact Switch	BE 42-683
HS	Hermetically Sealed Snap Switch	BE 42-694
V	Inductive Proximity Switch	BE 42-798
J	Bleed Type Pneumatic Switch	BE 42-685
K	Non-Bleed Type Pneumatic Switch	BE 42-686

## SWITCH DIFFERENTIAL ADJUSTMENT

The standard differential of the single float model T20 may be field adjusted. Adjustment may be necessary if a wider differential needs to be set to overcome switch chatter caused by the process.

The differential, or the amount of level travel between switch-on and switch-off, may be adjusted by repositioning the lower jam nuts on the float stem. The standard factory setting is for a minimum amount of play (gap) between the top jam nuts and the attraction sleeve as shown in **Figure 6**.

*NOTE: For assistance in computing level differential change for a specific control, consult the factory giving the model and serial numbers of the control.*

**CAUTION: Maximum differential adjustment is 13 mm (0.5").**

*NOTE: To widen the differential 13 mm (0.5"), the lower jam nuts must be set proportionately lower on the stem (i.e. in this example 13 mm (0.5")).*

**CAUTION: Before attempting any work on the control, pull disconnect switch, or otherwise assure that electrical circuit(s) through the control is deactivated. Close operating medium supply valve on controls equipped with pneumatic switch mechanisms.**

1. Determine what change in differential is necessary.
2. Make sure power source is turned off.
3. Unscrew and remove switch housing cover.
4. Disconnect power supply wires from switch mechanism. Pull wires out of cable gland opening in housing base. Refer to **Figure 5**.

5. Perform system shut-down procedures as required to relieve pressure from tank or vessel and drain off liquid head, if required. Allow unit to cool.

*NOTE: The amount of level travel between switch-on and switch-off actuations (differential) may be field adjusted by repositioning the lower jam nuts on the float stem. The standard factory setting is for a minimum amount of play (gap) between the top jam nuts and the attraction sleeve, as shown in **Figure 6**. This setting may be increased to a maximum of 13 mm (0.50"), as shown in **Figure 7**.*

6. Remove switch housing assembly by loosening enclosing tube nut, which is located immediately below housing base. Refer to **Figure 5**.

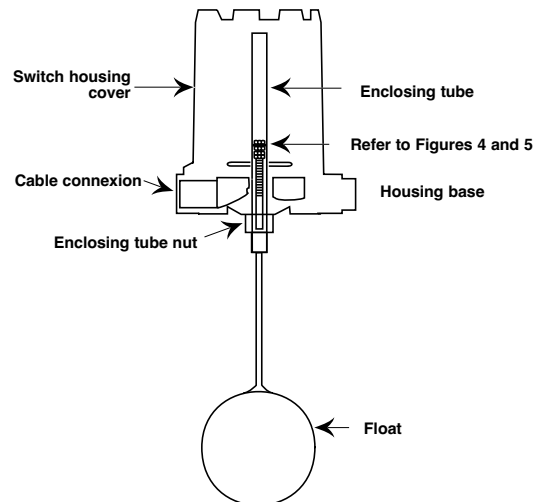
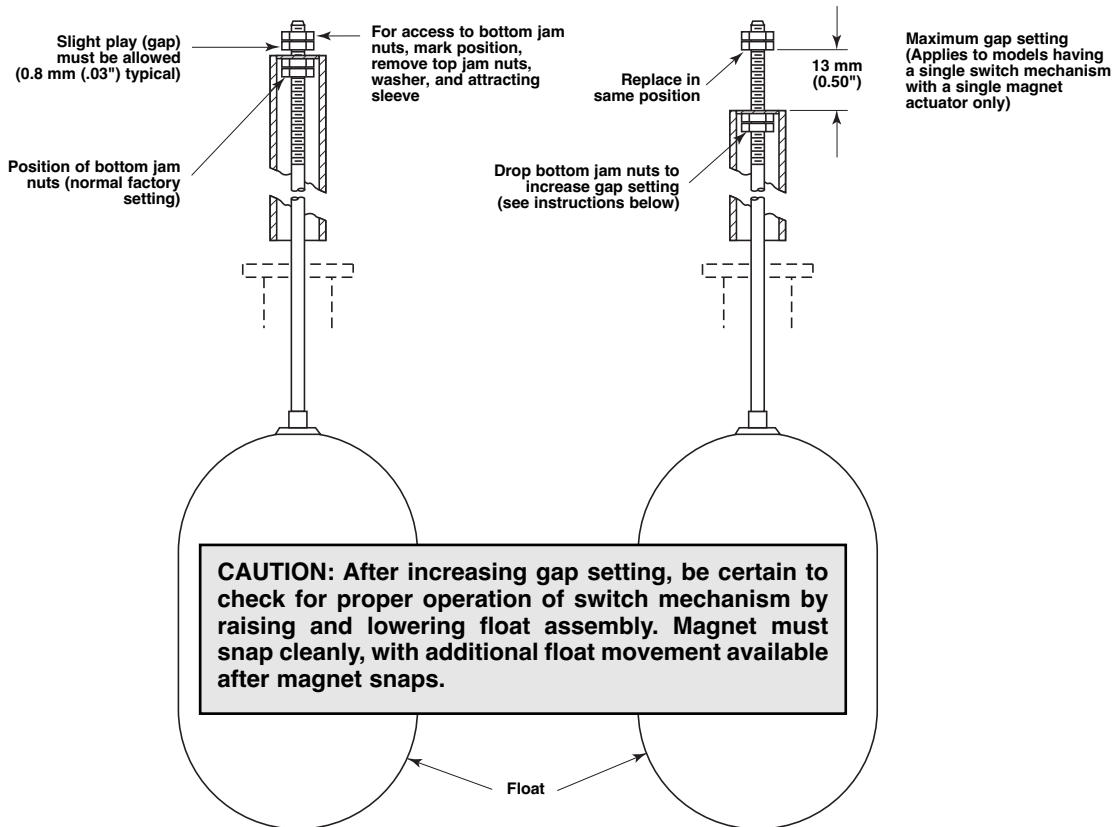

Figure 5



**CAUTION: After increasing gap setting, be certain to check for proper operation of switch mechanism by raising and lowering float assembly. Magnet must snap cleanly, with additional float movement available after magnet snaps.**

Figure 6

Normal Factory Setting  
(minimum differential)

Figure 7

Differential adjustment

## SWITCH DIFFERENTIAL ADJUSTMENT

7. With switch housing and enclosing tube removed, jam nuts and attraction sleeve are accessible. Measure position of upper jam nuts from stem end; then loosen and remove upper jam nuts, guide washer, and attraction sleeve.
8. Loosen and adjust lower jam nuts to desired position. Make certain jam nuts are retightened securely.

**NOTE:** Use new enclosing tube gasket in assembly of switch housing to the mounting bushing or flange. For part numbers, refer to replacement part section.

9. Test switch actuation by varying liquid level in tank or vessel.

**CAUTION:** Instructions given are for standard base model units which use a single magnet switch mechanism only. No differential adjustment should be attempted on tandem float models (T21) in the field. Switch actuation levels have been set at the factory to meet specific customer specifications. Variations in actual conditions from design conditions usually requires special control modifications. Consult with the factory or local representative for assistance.

## PREVENTIVE MAINTENANCE

Periodic inspections are a necessary means to keep your level control in good working order. This control is a safety device to protect the valuable equipment it serves. A systematic program of "preventive maintenance" must be implemented when the control is placed into service. If the following sections on "What to do" and "What to avoid" are observed, your control will provide reliable protection of your equipment for many years.

### What to do

#### 1. Keep control clean

Be sure the switch housing cover is always in place on the control. This cover is designed to keep dust and dirt from interfering with switch mechanism operation. In addition, it protects against damaging moisture and acts as a safety feature by keeping bare wires and terminals from being exposed. Should the housing cover become damaged or misplaced, order a replacement immediately.

#### 2. Inspect switch mechanisms, terminals and connections regularly

Dry contact switches should be inspected for excessive wear on actuating lever or misalignment of adjustment screw at point of contact between screw and lever. Such wear can cause false switch actuating levels<sup>①</sup>.

DO NOT operate your control with defective or maladjusted switch mechanisms<sup>①</sup>.

Level controls may sometimes be exposed to excessive heat or moisture. Under such conditions, insulation on electrical wiring may become brittle, eventually breaking or peeling away. The resulting "bare" wires can cause short circuits.

**NOTE:** Check wiring carefully and replace at the first sign of brittle insulation.

Vibration may sometimes cause terminal screws to loosen. Check all terminal connections to be certain that screws are tight.

On units with pneumatic switches, air (or gas) lines subjected to vibration, may eventually crack or become loose at connections causing leakage. Check lines and connections carefully and repair or replace, if necessary.

**NOTE:** Spare switches should be kept on hand at all times.

#### 3. Inspect entire unit periodically

Isolate control from vessel. Raise and lower liquid level to check for switch contact and reset.

### What to avoid

1. **NEVER** leave switch housing cover of the control longer than necessary to make routine inspections.
2. **NEVER** use lubricants on pivots of switch mechanisms. A sufficient amount of lubricant has been applied at the factory to insure a lifetime of service. Further oiling is unnecessary and will only tend to attract dust and dirt which can interfere with mechanism operation.
3. **NEVER** attempt to make adjustments or replace switches without reading instructions carefully. Certain adjustments provided for in Magnetrol controls should not be attempted in the field. When in doubt, consult the factory or your local Magnetrol representative.
4. **NEVER** place a jumper wire across terminals to "cut-out" the control. If a "jumper" is necessary for test purposes, be certain it is removed before placing control into service.

<sup>①</sup> See switch mechanisms bulletin furnished should switch adjustment or replacement be necessary.

Usually the first indication of improper operation is failure of the controlled equipment to function—pump will not start (or stop), signal lamps fail to light, etc. When these symptoms occur, whether at time of installation or during routing service thereafter, check the following potential external causes first.

- Fuses may be blown.
- Reset button(s) may need resetting.
- Power switch may be open.
- Controlled equipment may be faulty.
- Stem may be bent causing hang-up.
- Wiring (or medium lines) leading to control may be defective.

If a thorough inspection of these possible conditions fails to locate the trouble, proceed next to a check of the control's switch mechanism.

### Check switch mechanism

1. Pull disconnect switch or otherwise assure that electrical circuit(s) through the control is deactivated.
2. Remove switch housing cover.
3. Disconnect power wiring from switch assembly.
4. Swing magnet assembly in and out by hand, checking carefully for any sign of binding. Assembly should require minimal force, to move it through its full swing.
5. If binding exists, magnet may be rubbing enclosing tube. If magnet is rubbing, loosen magnet clamp screw and shift magnet position. Retighten magnet clamp screw.
6. If switch magnet assembly swings freely and mechanism still fails to actuate, check installation of control to be certain it is within the specified three (3°) degrees of vertical (use spirit level on side of enclosing tube in two places, 90° apart).
7. Check switch continuity with ohm meter. Replace immediately if found defective.

*NOTE: Spare switches should be kept on hand at all times.*

8. If switch mechanism is operating satisfactorily, a test of the complete control's performance is the next likely step.

### Test control's performance

1. Reconnect power supply and carefully actuate switch mechanism manually (using a non-conductive tool on electrical switch mechanism) to determine whether controlled equipment will operate.

**CAUTION: With electrical power "on" care should be taken to avoid contact with switch leads and connections at terminal block.**

2. If controlled equipment responds to manual actuation test, trouble may be located in level sensing portion of the control float(s), stem(s) and magnetic attracting sleeve(s).

*NOTE: Check first to be certain liquid is entering tank or vessel. A valve may be closed or pipe line plugged.*

**CAUTION: Be certain to pull disconnect switch or otherwise assure that electrical circuit(s) through control is deactivated. Close operating medium supply valve on controls equipped with pneumatic switch mechanisms.**







3. With liquid in tank or vessel, raise the liquid level above the set points. Magnets should "pull-in" on rising level. On Model T21 the lower float actuates the upper switch, and the upper float actuates the lower switch. If magnets fail to "pull-in", lower the level and purge pressure.
  - A. Disconnect wiring from supply side of switch mechanism(s) and remove electrical conduit or operating medium line connections to switch housing.
  - B. Relieve pressure from tank or vessel and allow unit to cool.
  - C. Remove switch housing assembly by loosening set screw located immediately below housing base.
4. With switch housing assembly removed, inspect attracting sleeve(s) and inside of enclosing tube for excessive corrosion or solids build-up which could restrict movement, preventing sleeve(s) from reaching field of switch magnet(s).
5. If differential has been changed in the field, check tightness and position of the jam nuts.

*NOTE: Differential adjustment affects a change in the amount of level travel between "switch on" and "switch off" actuations. Do NOT attempt adjustment without first consulting factory for assistance in computing level differential change for your control.*

6. Check float to be certain it is buoyant in the liquid (tank or vessel must have adequate liquid level). If float is determined to be filled with liquid or collapsed, it must be replaced immediately. Do NOT attempt to repair a float.

If all the components in the control are in operating condition, the trouble must be (and should be) located external to the control. Repeat inspection of external conditions previously described.

## AGENCY APPROVALS

AGENCY	APPROVED MODEL	AREA CLASSIFICATION
<b>ATEX</b>  	All with electric switch mechanism and housing listed as ATEX Ex d	ATEX II 2 G Ex d IIC T6 Gb
	All with electric switch mechanism and housing listed as ATEX Ex ia	ATEX II 1 G Ex ia IIC T6 Ga
<b>FM</b>  	All with electric switch mechanism and housing listed as NEMA 7/9	Class I, Div 1, groups C & D Class II, Div 1, Groups E, F & G
	Consult factory for proper model numbers	Class I, Div 1, groups B, C & D Class II, Div 1, Groups E, F & G
<b>IECEX</b>  	All with electric switch mechanism and housing listed as IECEX Ex d	Ex d IIC T6
	All with electric switch mechanism and housing listed as IECEX Ex ia	Ex ia IIC T6 Ga
<b>CSA</b>  	Consult factory for proper model numbers	Class I, Div 1, groups C & D Class II, Div 1, Groups E, F & G
	Consult factory for proper model numbers	Class I, Div 1, groups B, C & D Class II, Div 1, Groups E, F & G
<b>EAC (Russia, Kazakhstan, Belarus)</b>  	All with electric switch mechanism and housing listed as ATEX Ex d	1Ex d IIC T6 Gb
	All with electric switch mechanism and housing listed as ATEX Ex ia	0Ex ia IIC T4 Ga
<b>LRS</b>  	Lloyds Register of Shipping	Marine approval
<b>CE</b>  	The units are conform to the ATEX directive 2014/34/EU, The PED directive 2014/68/EU and the Low Voltage Directive 2014/35/EU	
Other approvals are available, consult factory for more details		

## SPECIFICATIONS

### Basic electrical ratings

Voltage	Switch Series and Non-Inductive Ampere Rating										
	B	C	D	F	HS	R	U	W	X	8	9
120 V AC	15.00	15.00	10.00	2.50	5.00	1.00	1.00	1.00	0.50	1.00	1.00
240 V AC	15.00	15.00	—	—	5.00	1.00	—	1.00	0.50	—	—
24 V DC	6.00	6.00	10.00	4.00	5.00	1.00	1.00	3.00	0.50	3.00	1.00
120 V DC	0.50	1.00	10.00	0.30	0.50	0.40	—	0.50	0.50	—	—
240 V DC	0.25	0.50	3.00	—	0.25	—	—	—	—	—	—

### Pressure temperature ratings

Process temperature Process pressure (for higher ratings consult factory)	ø 76 x 127 mm (3" x 5") float	Up to 34,5 bar (500 psi) @ 40 °C (100 °F) Up to 540 °C (1000 °F) @ 23,1 bar (335 psi)
	ø 89 x 152 mm (3 1/2" x 6") float	Up to 34,5 bar (500 psi) @ 40 °C (100 °F) Up to 540 °C (1000 °F) @ 26,4 bar (383 psi)
	ø 102 mm (4") float	Up to 41,3 bar (600 psi) @ 40 °C (100 °F) Up to 540 °C (1000 °F) @ 31,6 bar (459 psi)
	ø 114 mm (4 1/2") float	Up to 34,5 bar (500 psi) @ 40 °C (100 °F) Up to 540 °C (1000 °F) @ 26,4 bar (383 psi)



## SPECIFICATIONS

### Model T20 dimensional data in mm (inches)

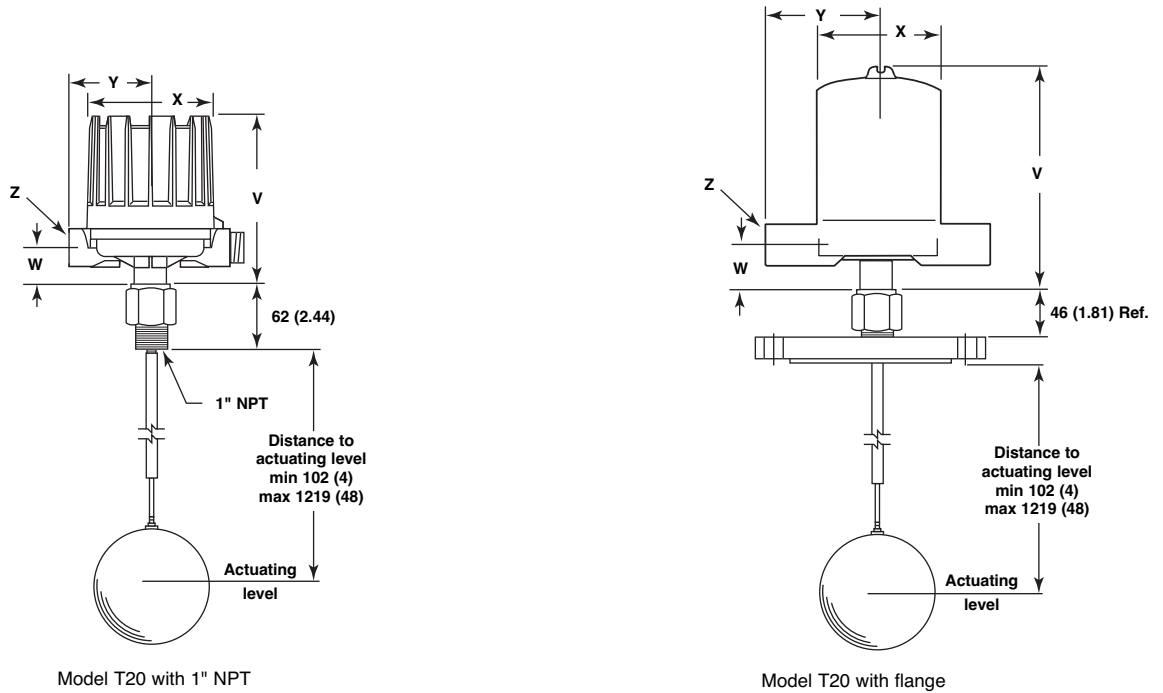

Model T20 with 1" NPT

Model T20 with flange

Housing type	Models	V	W	Ø X	Y	Z
Weatherproof-FM (NEMA 7/9) - ATEX (Cast Alu)	T20 with HS-switch	257 (10.12)	42 (1.66)	151 (5.93)	109 (4.29)	M20 x 1,5 (*) or 1" NPT (2 entries - 1 plugged) (*) not for FM (NEMA 7/9)
	T20 excl. HS-switch	202 (7.94)				
Weatherproof (CS/Aluminium)	T20	165 (6.50)	39 (1.54)	118 (4.65)	83 (3.27)	3/4" NPT (single entry)
ATEX (Cast Iron)	T20	249 (9.80)	45 (1.77)	143 (5.63)	110 (4.33)	M20 x 1,5 or 3/4" NPT (single entry - 2 entries at request)
Pneumatics Series J Bleed Type	T20	165 (6.50)	39 (1.54)	118 (4.65)	110 (4.33)	1/4" NPT
Pneumatics Series K Non Bleed					130 (5.12)	

Allow 200 mm (7.87") overhead clearance / All housings are 360 ° rotatable

### Float selection and max actuating level <sup>①</sup>

Liquid Specific Gravity	Float Size mm (inches)			
	Ø 76 x 127 (3" x 5")	Ø 89 x 152 (3 1/2" x 6")	Ø 102 (4")	Ø 114 (4 1/2")
1,00	991 (39)	1219 (48)	1219 (48)	1219 (48)
0,90	508 (20)	1219 (48)	838 (33)	1219 (48)
0,80	—	1219 (48)	279 (11)	1219 (48)
0,70	—	838 (33)	—	965 (38)
0,60	—	—	—	152 (6)

<sup>①</sup> The minimum actuation level is 102 mm (4")

## SPECIFICATIONS

### Model T21 dimensional data in mm (inches)

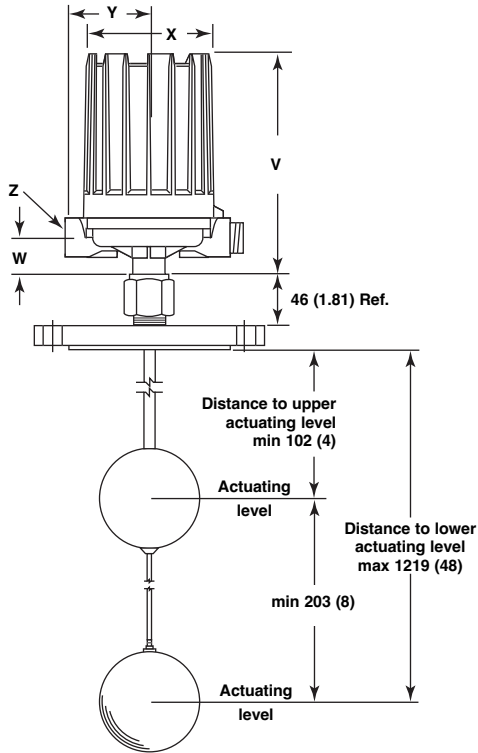

NOTE: On model T21, the lower float actuates the upper switch mechanism. The upper float actuates the lower switch mechanism.

Model T21 with flange

Housing type	Models	V	W	Ø X	Y	Z
Weatherproof-FM (NEMA 7/9) - ATEX (Cast Alu)	T21	257 (10.12)	42 (1.66)	151 (5.93)	109 (4.29)	M20 x 1,5 (*) or 1" NPT (2 entries - 1 plugged) (*) not for FM (NEMA 7/9)
Weatherproof (CS/Aluminium)	T21	216 (8.50)	39 (1.54)	118 (4.65)	83 (3.27)	3/4" NPT (single entry)
ATEX (Cast Iron)	T21	249 (9.80)	45 (1.77)	143 (5.63)	110 (4.33)	M20 x 1,5 or 3/4" NPT (single entry - 2 entries at request)

Allow 200 mm (7.87") overhead clearance / All housings are 360 ° rotatable

### Float selection and max actuating level <sup>①</sup>

Liquid Specific Gravity	Float Size mm (inches)					
	Ø 76 x 127 (3" x 5")		Ø 102 (4")		Ø 114 (4 1/2")	
	Upper	Lower	Upper	Lower	Upper	Lower
1,00	533 (21)	1219 (48)	813 (32)	1219 (48)	1016 (40)	1219 (48)
0,90	229 (9)	762 (30)	457 (18)	1118 (44)	1016 (40)	1219 (48)
0,80	—	—	102 (4)	533 (21)	1016 (40)	1219 (48)
0,70	—	—	—	—	533 (21)	1219 (48)

<sup>①</sup> The minimum actuating level is 102 mm (4"). The minimum distance between the top and bottom actuating levels is 203 mm (8").

# REPLACEMENT PARTS

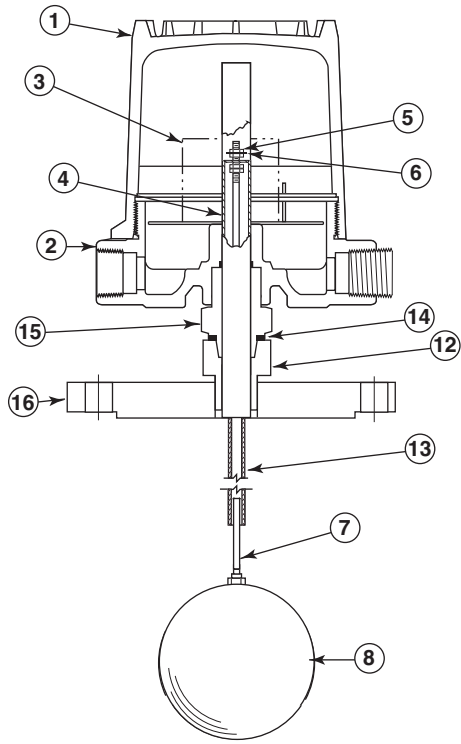

T20

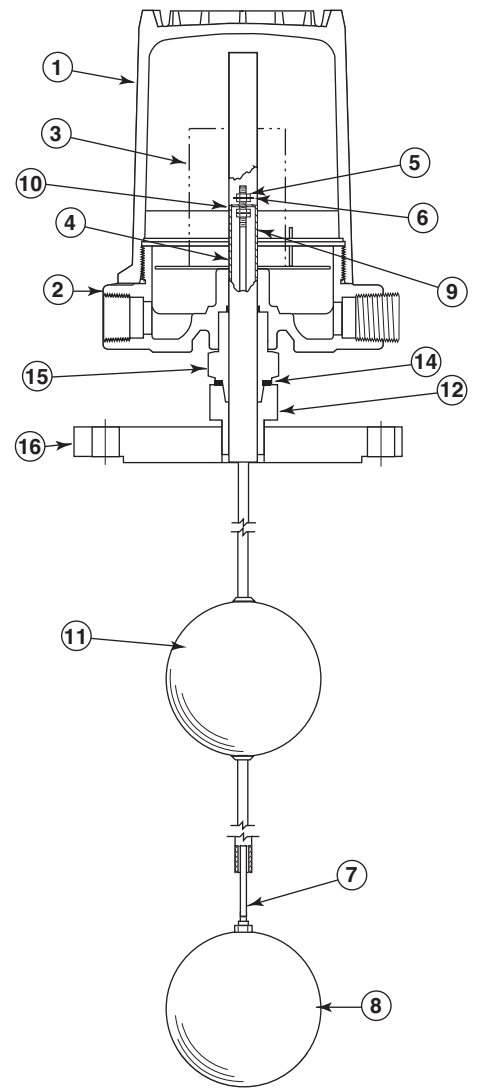

T21

## REPLACEMENT PARTS

ITEM	DESCRIPTION		SINGLE FLOAT MODELS		TANDEM FLOAT MODELS	
			T20-A	T20-B/D	T21-A	T21-B/D
1	Housing Cover	Housing Kits	Refer to bulletin on switch mechanism and housing furnished (listed on page 3).			
2	Housing Base					
3	Switch Mechanism(s)					
4	Attraction Sleeve	Float Stem Kit ① ②	consult factory			
5	Jam Nuts					
6	Guide Washer(s)					
7	Float Stem					
8	Float	FLOAT SIZE 3" x 5"	Z07-1202-003	Z07-1202-003		
		3,5" x 6"	Z07-1202-009	not applicable		
		4"	Z07-1102-008	Z07-1102-008		
		4.50"	Z07-1102-009	Z07-1102-009		
9	Attraction Sleeve, Stop Tube, and Washers	Upper Float and Tube Assy. Kit ① ②	not applicable		consult factory	
10	Retaining Rings					
11	Float and Tube Assy.					
12	Adaptor Bushing	consult factory		004-5734-123		
13	Stem Guide Tube ②			not applicable		
14	E-Tube Gasket	012-1204-001				
15	Enclosing Tube Kit (includes E-tube gasket item 14)	Cast iron housing	089-5933-029			
		Cast aluminium housing	089-5933-027	089-5933-028		
		Pneumatic switch housing	089-5933-027	not applicable		
16	Mounting Flange ③	consult factory				

### IMPORTANT:

When ordering, please specify:

A. Model and serial number of control.

B. Name and number of replacement part or assembly (Kit).

### NOTES:

- ① All replacements furnished in kit form are for standard base models which use single magnet switch mechanisms only. Consult local representative for ordering assistance on all special model replacement parts not included in above listing.
- ② Float stem and tube component lengths are cut to meet original customer specifications. When ordering these replacement kits, be certain to always give complete model and serial numbers of control.
- ③ When ordering flanges, please specify serial number, type and size.

# MODEL IDENTIFICATION T20 SINGLE SWITCH MODEL

A complete measuring system consists of:

Code for **T20** models (each unit is factory calibrated to operate on a given specific gravity within the min and the max values listed per model)

## MODEL NUMBER CODE AND MATERIALS OF CONSTRUCTION

Model No.	Set points	Process /Tank connection	Float and trim	Magnetic sleeve
T20-A	1 - Single float	Carbon steel	316 SST (1.4401)	400 series SST
T20-B				316 SST (1.4401)
T20-D		316 SST (1.4401)		316 SST (1.4401)

**Important:** Actuating level, in either the rising or falling state, and specific gravity must be provided upon placement of order. The maximum available actuating level is governed by the liquid specific gravity and selected float size as given in the table below. The minimum actuating level is 102 mm (4 inches).

### FLOAT SELECTION AND MAX ACTUATING LEVEL <sup>①</sup>

Liquid Specific Gravity	Float Size mm (inches)			
	Ø 76 x 127 (3" x 5")	Ø 89 x 152 (3 1/2" x 6")	Ø 102 (4")	Ø 114 (4 1/2")
1,00	991 (39)	1219 (48)	1219 (48)	1219 (48)
0,90	508 (20)	1219 (48)	838 (33)	1219 (48)
0,80	—	1219 (48)	279 (11)	1219 (48)
0,70	—	838 (33)	—	965 (38)
0,60	—	—	—	152 (6)

<sup>①</sup> The minimum actuation level is 102 mm (4")

### FLOAT PRESSURE RATINGS

Float Size mm (inches)	Pressure Rating bar (PSIG)			
	40 °C (100 °F)	400 °C (750 °F)	480 °C <sup>①</sup> (900 °F)	540 °C <sup>①</sup> (1000 °F)
Ø 76 x 127 (3" x 5")	34,4 (500)	26,0 (377)	24,3 (353)	23,1 (335)
Ø 89 x 152 (3 1/2" x 6")	34,4 (500)	27,7 (403)	26,7 (388)	26,4 (383)
Ø 102 (4")	41,3 (600)	33,3 (483)	32,0 (465)	31,6 (459)
Ø 114 (4 1/2")	34,4 (500)	27,7 (403)	26,7 (388)	26,4 (383)

<sup>①</sup> Upon prolonged exposure to temperatures above 425 °C (800 °F), the carbide phase of steel may be converted to graphite. Permissible but not recommended for prolonged use above 425 °C (800 °F). (Applies to models T20-A & T20-B.)

### TANK CONNECTION AND FLOAT SIZE

Tank Connection	Float sizes			
	Ø 76 x 127 mm (3" x 5")	Ø 102 mm (4")	Ø 114 mm (4 1/2")	Ø 89 x 152 mm (3 1/2" x 6")
<b>Threaded NPT connection</b>				
1" NPT	B2A	B2B	B2C	B2D
<b>ASME Flanges <sup>①</sup></b>				
4" 150 lbs RF	H3A	—	—	H3D <sup>②</sup>
4" 300 lbs RF	H4A	—	—	H4D <sup>②</sup>
5" 150 lbs RF	J3A	J3B	J3C <sup>②</sup>	J3D
5" 300 lbs RF	J4A	J4B	J4C <sup>②</sup>	J4D
6" 150 lbs RF	K3A	K3B	K3C	K3D
6" 300 lbs RF	K4A	K4B	K4C	K4D
8" 150 lbs RF	L3A	L3B	L3C	L3D
<b>EN 1092-1 flanges <sup>①</sup></b>				
DN 100 PN16, Type B1	8FA	—	—	8FD <sup>②</sup>
DN 100 PN 25/40, Type B1	8GA	—	—	8GD <sup>②</sup>
DN 150 PN16, Type B1	9FA	9FB	9FC	9FD
DN 150 PN 25/40, Type B1	9GA	9GB	9GC	9GD

<sup>①</sup> Flanges are threaded onto 1" NPT bushing

<sup>②</sup> Float cannot pass S160 nozzle or greater

SWITCH MECHANISM & HOUSING (next page)



complete code for T20 models

X = product with a specific customer requirement

## MODEL IDENTIFICATION T20 SINGLE SWITCH MODEL

### SELECT ELECTRIC SWITCH MECHANISM & HOUSING

Switch Description	Process ① Temperature Range °C (°F)	Contacts	T20-A Models										T20-B and T20-D Models									
			Weather proof (IP 66)		ATEX - IECEx (IP 66)						FM (IP 66)		Weather proof (IP 66)		ATEX - IECEx (IP 66)						FM (IP 66)	
					II 2G Ex d IIC T6 Gb			II 1G Ex ia IIC T6 Ga			NEMA 7/9	II 2G Ex d IIC T6 Gb			II 1G Ex ia IIC T6 Ga			NEMA 7/9				
			Cast Aluminium		Cast Aluminium		Cast Iron (ATEX only)		Cast Aluminium		Cast Al.	Cast Aluminium		Cast Aluminium		Cast Iron (ATEX only)		Cast Aluminium		Cast Al.		
			M20x1,5	1" NPT	M20x1,5	1" NPT	M20x1,5	3/4" NPT	M20x1,5	1" NPT	1" NPT	M20x1,5	1" NPT	M20x1,5	1" NPT	M20x1,5	3/4" NPT	M20x1,5	1" NPT	1" NPT		
Series B Snap switch	-40 to +120 (-40 to +250)	1x SPDT	B2P	BAP	BHC	BAC	BK7	BU7	–	–	BKP	B2Q	BAQ	BH9	BA9	BK5	BU5	–	–	BKQ		
		1x DPDT	B8P	BDP	BJC	BBC	BD7	BW7	–	–	BNP	B8Q	BDQ	BJ9	BB9	BD5	BW5	–	–	BNQ		
Series C Snap switch	-40 to +230 (-40 to +450)	1x SPDT	C2P	CAP	CHC	CAC	CK7	CU7	C2L	CAL	CKP	C2Q	CAQ	CH9	CA9	CK5	CU5	C2S	CAS	CKQ		
		1x DPDT	C8P	CDP	CJC	CBC	CD7	CW7	C8L	CDL	CNP	C8Q	CDQ	CJ9	CB9	CD5	CW5	C8S	CDS	CNQ		
Series D DC Current Snap switch	-40 to +120 (-40 to +250)	1x SPDT	D2Q	DAQ	DH9	DA9	DK5	DU5	–	–	DKQ	D2Q	DAQ	DH9	DA9	DK5	DU5	–	–	DKQ		
		1x DPDT	D8Q	DDQ	DJ9	DB9	DD5	DW5	–	–	DNQ	D8Q	DDQ	DJ9	DB9	DD5	DW5	–	–	DNQ		
Series F Hermetically sealed Snap switch	-45 to +400 (-50 to +750)	1x SPDT	F2P	FAP	FHC	FAC	FK7	FU7	–	–	FKP	F2Q	FAQ	FH9	FA9	FK5	FU5	–	–	FKQ		
		1x DPDT	F8P	FDP	FJC	FBC	FD7	FW7	–	–	FNP	F8Q	FDQ	FJ9	FB9	FD5	FW5	–	–	FNQ		
Series HS Hermetically sealed Snap switch	-45 to +290 ② (-50 to +550)	1x SPDT	H7A	HM2	HFC	HA9	HB3	HB4	–	–	HM3	H7A	HM2	HFC	HA9	HB3	HB4	–	–	HM3		
		1x DPDT	H7C	HM6	HGC	HB9	HB7	HB8	–	–	HM7	H7C	HM6	HGC	HB9	HB7	HB8	–	–	HM7		
Series U Gold alloy contacts Snap switch	-40 to +120 (-40 to +250)	1x SPDT	U2P	UAP	UHC	UAC	UK7	UU7	U2L	UAL	UKP	U2Q	UAQ	UH9	UA9	UK5	UU5	U2S	UAS	UKQ		
		1x DPDT	U8P	UDP	UJC	UBC	UD7	UW7	U8L	UDL	UNP	U8Q	UDQ	UJ9	UB9	UD5	UW5	U8S	UDS	UNQ		
Series V Inductive Proximity switch	-40 to +100 (-40 to +210)	–	–	–	–	–	–	VFS	VHS	–	–	–	–	–	–	–	–	V5S	VBS	–		
Series W Hermetically sealed Silver plated contacts Snap switch	-45 to +230 (-50 to +450)	1x SPDT	W2P	WAP	WHC	WAC	WK7	WU7	W2L	WAL	WKP	W2Q	WAQ	WH9	WA9	WK5	WU5	W2S	WAS	WKQ		
		1x DPDT	W8P	WDQ	WJ9	WB9	WD5	WW5	W8S	WDS	WNQ	W8Q	WDQ	WJ9	WB9	WD5	WW5	W8S	WDS	WNQ		
Series X Hermetically sealed Gold plated contacts Snap switch	-45 to +230 (-50 to +450)	1x SPDT	X2P	XAP	XHC	XAC	XK7	XU7	X2L	XAL	XKP	X2Q	XAQ	XH9	XA9	XK5	XU5	X2S	XAS	XKQ		
		1x DPDT	X8P	XDQ	XJ9	XB9	XD5	XW5	X8S	XDS	XNQ	X8Q	XDQ	XJ9	XB9	XD5	XW5	X8S	XDS	XNQ		
Series R High temperature Snap switch	-40 to +400 (-40 to +750)	1x SPDT	R2Q	R1Q	RH9	RA9	RK5	RU5	–	–	RKQ	R2Q	R1Q	RH9	RA9	RK5	RU5	–	–	RKQ		
		1x DPDT	R8Q	RDQ	RJ9	RB9	RN5	RF5	–	–	RNQ	R8Q	RDQ	RJ9	RB9	RN5	RF5	–	–	RNQ		
Series 8 Hermetically sealed Snap switch	-45 to +400 (-50 to +750)	1x SPDT	82P	8AP	8HC	8AC	8K7	8U7	–	–	8KP	82Q	8AQ	8H9	8A9	8K5	8U5	–	–	8KQ		
		1x DPDT	88P	8DP	8JC	8BC	8D7	8W7	–	–	8NP	88Q	8DQ	8J9	8B9	8D5	8W5	–	–	8NQ		
Series 9 High temperature Hermetically sealed Snap switch	-45 to +400 (-50 to +750)	1x SPDT	92P	9AP	9HC	9AC	9K7	9U7	–	–	9KP	92Q	9AQ	9H9	9A9	9K5	9U5	–	–	9KQ		
		1x DPDT	98P	9DP	9JC	9BC	9D7	9W7	–	–	9NP	98Q	9DQ	9J9	9B9	9D5	9W5	–	–	9NQ		
Switch Description	Process ① Temperature Range °C (°F)	Contacts	Weather proof (IP 65)		ATEX (IP 66)				Weather proof (IP 65)		ATEX (IP 66)											
					II 2G Ex d IIC T6 Gb						II 2G Ex d IIC T6 Gb											
			CS/Aluminium		Cast Iron				CS/Aluminium		Cast Iron											
			3/4" NPT		M20x1,5		3/4" NPT		3/4" NPT		M20x1,5		3/4" NPT									
Series R High temperature Snap switch	-40 to +540 ③ (-40 to +1000)	1x SPDT	R1Y		RK5		RU5		R1Y		RK5		RU5									
		1x DPDT	RDY		RN5		RF5		RDY		RN5		RF5									
Series 9 High temperature Hermetically sealed Snap switch	-40 to +540 ③ (-40 to +1000)	1x SPDT	9AR		9K7		9U7		9AY		9K5		9U5									
		1x DPDT	9DR		9D7		9W7		9DY		9D5		9W5									

### SELECT PNEUMATIC SWITCH MECHANISM & HOUSING

Switch Description	Max supply pressure bar (psi)	Max liquid temperature ① °C (°F)	Bleed orifice Ø mm (inches)	NEMA 3R (IP 53)	
				T20-A Models	T20-B & T20-D Models
Series J (open air)	6,9 (100)	200 (400)	1,60 (0.063)	JDG	JDE
	4,1 (60)		2,39 (0.094)	JEG	JEE
	4,1 (60)		1,40 (0.055)	JFG	JFE
Series K (closed circuit)	6,9 (100)	200 (400)	–	KOE	KOE
	2,8 (40)		–	KOG	–

① Process temperature based on max. 40 °C (100 °F) ambient temperature and for non steam applications.

② On steam applications, temperature down-rated to +200 °C (+400 °F) process at +40 °C (+100 °F) ambient.

③ Upon prolonged exposure to temperatures above 425 °C (800 °F), the carbide phase of steel may be converted to graphite. Permissible but not recommended for prolonged use above 425 °C (800 °F). (Applies to models T20-A & T20-B.)

# MODEL IDENTIFICATION T21 DUAL SWITCH MODEL

A complete measuring system consists of:

Code for T21 models (each unit is factory calibrated to operate on a given specific gravity within the min and the max values listed per model)

## MODEL NUMBER CODE AND MATERIALS OF CONSTRUCTION

Model No.	Set points	Process /Tank connection	Float and trim	Magnetic sleeve
T21-A	2 - Tandem float	Carbon steel	316 SST (1.4401)	400 series SST
T21-B				316 SST (1.4401)
T21-D		316 SST (1.4401)		316 SST (1.4401)

**Important:** Actuating level, in either the rising or falling state, and specific gravity must be provided upon placement of order. The maximum available actuating level is governed by the liquid specific gravity and selected float size as given in the table below. The minimum actuating level is 102 mm (4 inches). The minimum distance between the top and bottom actuating levels is 203 mm (8 inches).

### FLOAT SELECTION AND MAX ACTUATING LEVEL <sup>①</sup>

Liquid Specific Gravity	Float Size mm (inches)					
	Ø 76 x 127 (3" x 5")		Ø 102 (4")		Ø 114 (4 1/2")	
	Upper	Lower	Upper	Lower	Upper	Lower
1,00	533 (21)	1219 (48)	813 (32)	1219 (48)	1016 (40)	1219 (48)
0,90	229 (9)	762 (30)	457 (18)	1118 (44)	1016 (40)	1219 (48)
0,80	—	—	102 (4)	533 (21)	1016 (40)	1219 (48)
0,70	—	—	—	—	533 (21)	1219 (48)

<sup>①</sup> The minimum actuating level is 102 mm (4"). The minimum distance between the top and bottom actuating levels is 203 mm (8").

### FLOAT PRESSURE RATINGS

Float Size mm (inches)	Pressure Rating bar (PSIG)			
	40 °C (100 °F)	400 °C (750 °F)	480 °C <sup>①</sup> (900 °F)	540 °C <sup>①</sup> (1000 °F)
Ø 76 x 127 (3" x 5")	34,4 (500)	26,0 (377)	24,3 (353)	23,1 (335)
Ø 102 (4")	41,3 (600)	33,3 (483)	32,0 (465)	31,6 (459)
Ø 114 (4 1/2")	34,4 (500)	27,7 (403)	26,7 (388)	26,4 (383)

<sup>①</sup> Upon prolonged exposure to temperatures above 425 °C (800 °F), the carbide phase of steel may be converted to graphite. Permissible but not recommended for prolonged use above 425 °C (800 °F). (Applies to models T20-A & T20-B.)

### TANK CONNECTION AND FLOAT SIZE

Tank Connection	Float sizes		
	Ø 76 x 127 mm (3" x 5")	Ø 102 mm (4")	Ø 114 mm (4 1/2")
<b>ASME Flanges <sup>①</sup></b>			
4" 150 lbs RF	H3A	—	—
4" 300 lbs RF	H4A	—	—
5" 150 lbs RF	J3A	J3B	J3C <sup>②</sup>
5" 300 lbs RF	J4A	J4B	J4C <sup>②</sup>
6" 150 lbs RF	K3A	K3B	K3C
6" 300 lbs RF	K4A	K4B	K4C
8" 150 lbs RF	L3A	L3B	L3C
<b>EN 1092-1 flanges <sup>①</sup></b>			
DN 100 PN16, Type B1	8FA	—	—
DN 100 PN 25/40, Type B1	8GA	—	—
DN 150 PN16, Type B1	9FA	9FB	9FC
DN 150 PN 25/40, Type B1	9GA	9GB	9GC

<sup>①</sup> Flanges are threaded onto 1" NPT bushing

<sup>②</sup> Float cannot pass S160 nozzle or greater

SWITCH MECHANISM & HOUSING (next page)

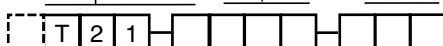

complete code for T21 models

X = product with a specific customer requirement

# MODEL IDENTIFICATION T21 DUAL SWITCH MODEL

## SELECT ELECTRIC SWITCH MECHANISM & HOUSING

Switch Description	Process ① Temperature Range °C (°F)	Contacts	T21-A Models										T21-B and T21-D Models											
			Weather proof (IP 66)	ATEX - IECEx (IP 66)								FM (IP 66)	Weather proof (IP 66)	ATEX - IECEx (IP 66)								FM (IP 66)		
				II 2G Ex d IIC T6 Gb					II 1G Ex ia IIC T6 Ga					NEMA 7/9	II 2G Ex d IIC T6 Gb					II 1G Ex ia IIC T6 Ga			NEMA 7/9	
				Cast Aluminium		Cast Iron (ATEX only)			Cast Aluminium		Cast Alu.				Cast Aluminium		Cast Iron (ATEX only)			Cast Aluminium				Cast Alu.
				M20x1,5	1" NPT	M20x1,5	1" NPT	M20x1,5	3/4" NPT	M20x1,5					1" NPT	1" NPT	M20x1,5	1" NPT	M20x1,5	3/4" NPT	M20x1,5			
Series B Snap switch	-40 to +120 (-40 to +250)	2x SPDT	B4A	BBA	BLC	BDC	BL7	BV7	–	–	BLA	B4B	BBB	BL9	BD9	BL5	BV5	–	–	BLB				
		2x DPDT	B1A	BEA	BPC	BGC	BO7	BY7	–	–	BOA	B1B	BEB	BP9	BG9	BO5	BY5	–	–	BOB				
Series C Snap switch	-40 to +230 (-40 to +450)	2x SPDT	C4A	CBA	CLC	CDC	CL7	CV7	C4X	CBX	CLA	C4B	CBB	CL9	CD9	CL5	CV5	C4T	CBT	CLB				
		2x DPDT	C1A	CEA	CPC	CGC	CO7	CY7	C1X	CEX	COA	C1B	CEB	CP9	CG9	CO5	CY5	C1T	CET	COB				
Series D DC Current Snap switch	-40 to +120 (-40 to +250)	2x SPDT	D4B	DBB	DL9	DD9	DL5	DV5	–	–	DLB	D4B	DBB	DL9	DD9	DL5	DV5	–	–	DLB				
		2x DPDT	D1B	DEB	DP9	DG9	DO5	DY5	–	–	DOB	D1B	DEB	DP9	DG9	DO5	DY5	–	–	DOB				
Series F Hermetically sealed Snap switch	-45 to +400 (-50 to +750)	2x SPDT	FFA	FBA	FLC	FDC	FL7	FV7	–	–	FLA	FFB	FBB	FL9	FD9	FL5	FV5	–	–	FLB				
		2x DPDT	FHA	FEA	FPC	FGC	FO7	FY7	–	–	FOA	FHB	FEB	FP9	FG9	FO5	FY5	–	–	FOB				
Series U Gold alloy contacts Snap switch	-40 to +120 (-40 to +250)	2x SPDT	U4A	UBA	ULC	UDC	UL7	UV7	U4X	UBX	ULA	U4B	UBB	UL9	UD9	UL5	UV5	U4T	UBT	ULB				
		2x DPDT	U1A	UEA	UPC	UGC	UO7	UY7	U1X	UEX	UOA	U1B	UEB	UP9	UG9	UO5	UY5	U1T	UET	UOB				
Series W Hermetically sealed Silver plated contacts Snap switch	-45 to +230 (-50 to +450)	2x SPDT	W4A	WBA	WLC	WDC	WL7	WV7	W4X	WBX	WLA	W4B	WBB	WL9	WD9	WL5	WV5	W4T	WBT	WLB				
		2x DPDT	W1B	WEB	WP9	WG9	WO5	WY5	W1T	WET	WOB	W1B	WEB	WP9	WG9	WO5	WY5	W1T	WET	WOB				
Series X Hermetically sealed Gold plated contacts Snap switch	-45 to +230 (-50 to +450)	2x SPDT	X4A	XBA	XLC	XDC	XL7	XV7	X4X	XBX	XLA	X4B	XBB	XL9	XD9	XL5	XV5	X4T	XBT	XLB				
		2x DPDT	X1B	XEB	XP9	XG9	XO5	XY5	X1T	XET	XOB	X1B	XEB	XP9	XG9	XO5	XY5	X1T	XET	XOB				
Series R High temperature Snap switch	-40 to +400 (-40 to +750)	2x SPDT	R4B	R3B	RL9	RD9	RL5	RV5	–	–	RLB	R4B	R3B	RL9	RD9	RL5	RV5	–	–	RLB				
		2x DPDT	RHB	REB	RP9	RG9	RO5	RG5	–	–	ROB	RHB	REB	RP9	RG9	RO5	RG5	–	–	ROB				
Series 8 Hermetically sealed Snap switch	-45 to +400 (-50 to +750)	2x SPDT	84A	8BA	8LC	8DC	8L7	8V7	–	–	8LA	84B	8BB	8L9	8D9	8L5	8V5	–	–	8LB				
		2x DPDT	81A	8EA	8PC	8GC	8O7	8Y7	–	–	8OA	81B	8EB	8P9	8G9	8O5	8Y5	–	–	8OB				
Series 9 High temperature Hermetically sealed Snap switch	-45 to +400 (-50 to +750)	2x SPDT	94A	9BA	9LC	9DC	9L7	9V7	–	–	9LA	94B	9BB	9L9	9D9	9L5	9V5	–	–	9LB				
		2x DPDT	91A	9EA	9PC	9GC	9O7	9Y7	–	–	9OA	91B	9EB	9P9	9G9	9O5	9Y5	–	–	9OB				
Switch Description	Process ① Temperature Range °C (°F)	Contacts	Weather proof (IP 65)	ATEX (IP 66)						Weather proof (IP 65)	ATEX (IP 66)													
				II 2G Ex d IIC T6 Gb							II 2G Ex d IIC T6 Gb													
				CS/Aluminium			Cast Iron				CS/Aluminium			Cast Iron										
				3/4" NPT		M20x1,5	3/4" NPT				3/4" NPT		M20x1,5	3/4" NPT										
Series R High temperature Snap switch	-40 to +540 ② (-40 to +1000)	2x SPDT	R3M			RL5			RV5			R3M			RL5			RV5						
		2x DPDT	REM			RO5			RG5			REM			RO5			RG5						
Series 9 High temperature Hermetically sealed Snap switch	-40 to +540 ② (-40 to +1000)	2x SPDT	9BD			9L7			9V7			9BM			9L5			9V5						
		2x DPDT	9ED			9O7			9Y7			9EM			9O5			9Y5						

① Process temperature based on max. 40 °C (100 °F) ambient temperature and for non steam applications.

② Upon prolonged exposure to temperatures above 425 °C (800 °F), the carbide phase of steel may be converted to graphite. Permissible but not recommended for prolonged use above 425 °C (800 °F). (Applies to models T20-A & T20-B.)









# IMPORTANT

## SERVICE POLICY

Owners of Magnetrol products may request the return of a control; or, any part of a control for complete rebuilding or replacement. They will be rebuilt or replaced promptly. Magnetrol International will repair or replace the control, at no cost to the purchaser, (or owner) **other than transportation cost** if:

- a. Returned within the warranty period; and,
- b. The factory inspection finds the cause of the malfunction to be defective material or workmanship.

If the trouble is the result of conditions beyond our control; or, is **NOT** covered by the warranty, there will be charges for labour and the parts required to rebuild or replace the equipment.

In some cases, it may be expedient to ship replacement parts; or, in extreme cases a complete new control, to replace the original equipment before it is returned. If this is desired, notify the factory of both the model and serial numbers of the control to be replaced. In such cases, credit for the materials returned, will be determined on the basis of the applicability of our warranty.

No claims for misapplication, labour, direct or consequential damage will be allowed.

## RETURNED MATERIAL PROCEDURE

So that we may efficiently process any materials that are returned, it is essential that a "Return Material Authorisation" (RMA) form will be obtained from the factory. It is mandatory that this form will be attached to each material returned. This form is available through Magnetrol's local representative or by contacting the factory. Please supply the following information:

1. Purchaser Name
2. Description of Material
3. Serial Number and Ref Number
4. Desired Action
5. Reason for Return
6. Process details

Any unit that was used in a process must be properly cleaned in accordance with the proper health and safety standards applicable by the owner, before it is returned to the factory.

A material Safety Data Sheet (MSDS) must be attached at the outside of the transport crate or box.

All shipments returned to the factory must be by prepaid transportation. Magnetrol **will not accept** collect shipments.

All replacements will be shipped Ex Works.

UNDER RESERVE OF MODIFICATIONS

BULLETIN: BE 44-604.12  
EFFECTIVE: OCTOBER 2019  
SUPERSEDES: April 2018

---

### European Headquarters & Manufacturing Facility

Heikensstraat 6

9240 Zele, Belgium

Tel: +32-(0)52-45.11.11 • Fax: +32-(0)52-45.09.93

e-mail: info@magnetrol.be

**www.magnetrol.com**

