

Displacer Type

Installation and Operating Manual

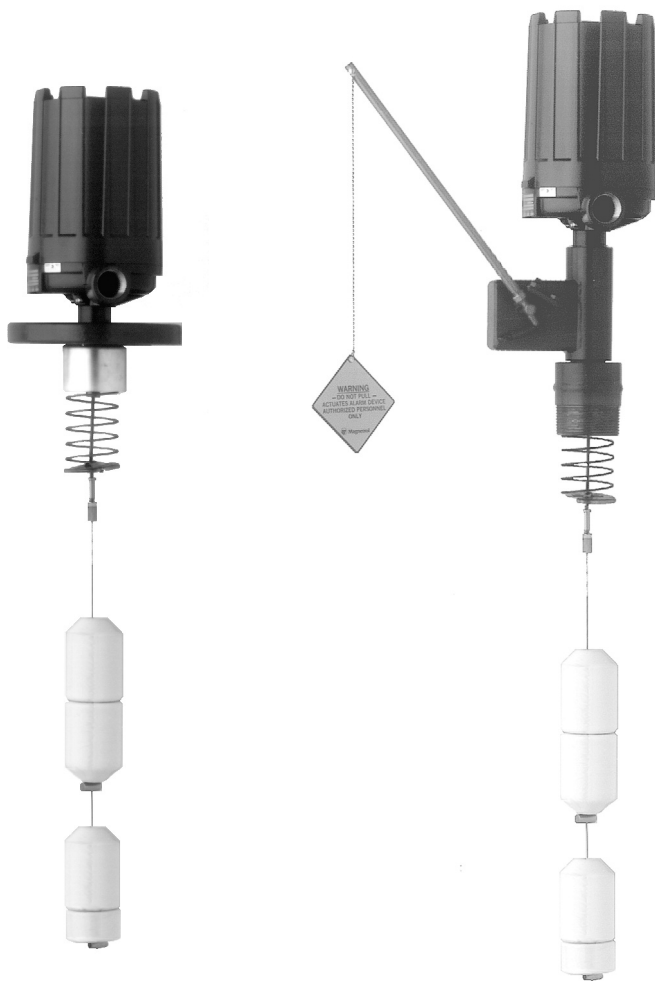

*Liquid
Level
and
Proof-er[®]
Switches*

UNPACKING

Top mounting displacer units are shipped from the factory with the displacer and cable assembly removed from the head assembly and packed separately in the same container. Unpack the instrument carefully. Make sure all components have been removed from the packing material. Inspect all components for damage. Report any concealed damage to the carrier within 24 hours. Check the contents of the packing slip and report any discrepancies to the factory. Check the nameplate model number to be sure it agrees with the packing slip and purchase order. Check and record the serial number for future reference when ordering parts.

CAUTION: If re-shipping to another location, displacer assembly must again be secured using same strap and wire assembly.

After unpacking, inspect all components to see that no damage has occurred during shipment.

Nameplate:
- part number
- serial n°

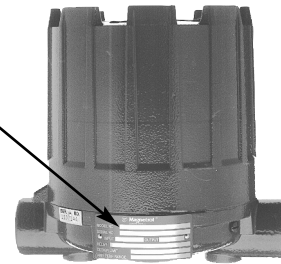

These units are in conformity with the provisions of:

1. Directive 2014/34/EU for equipment or protective system intended for use in potentially explosive atmospheres. EC-type examination certificate number ISSeP09ATEX024X (Ex d units) or KIWA18ATEX0022X (Ex i units).

CAUTION: The threaded connection link protruding from the head assembly is extremely fragile. DO NOT handle or place in a position such that any amount of force is placed on the stem. Proper operation of the control requires that the stem is not damaged or bent.

SPECIAL CONDITIONS FOR ATEX INTRINSICALLY SAFE USE

When the product is installed in an area requiring EPL Ga and the enclosure is made of aluminium, all precautions shall be taken in order to avoid all impacts or frictions which can result in the ignition of the potentially explosive atmosphere.

INTRODUCTION

Displacement type level switches offer the industrial user a wide choice of alarm and control configurations. These units utilize simple buoyancy principle and are well suited for simple or complex applications.

PRINCIPLE OF OPERATION

Standard controls

Operation is based upon simple buoyancy, whereby a spring is loaded with weighted displacers which are heavier than the liquid. Immersion of the displacers in the liquid results in buoyancy force change, which moves the spring upward. Since the spring moves only when the level moves on a displacer, spring movement (1) is always a small fraction of the level travel between displacers (2).

A magnetic sleeve (3) is connected to the spring and operates within a non-magnetic barrier tube (4). Spring movement causes the magnetic sleeve to attract a pivoted magnet (5), actuating a switch mechanism (6) located outside the barrier tube. Built-in limit stops, prevent over stroking of the spring under level surge conditions.

Proof-er® controls

The purpose of the PROOF-ER is to check the operation of a displacer control without having to raise the level in the tank. This is accomplished by pulling downward on the PROOF-ER cable. A spring-loaded lever arm then lifts the cable actuator simulating a high or high-high level condition. When the cable is released, the PROOF-ER returns the actuator to its previous position to resume normal operation.

Floating roof controls

The floating roof control is designed for installation on 'barrier' (floating roof) tanks. The control may be furnished with a brass displacer to prevent sparking. A hollow brass displacer is required if the control is to actuate in liquid as well as by the barrier. A stainless steel displacer is also available.

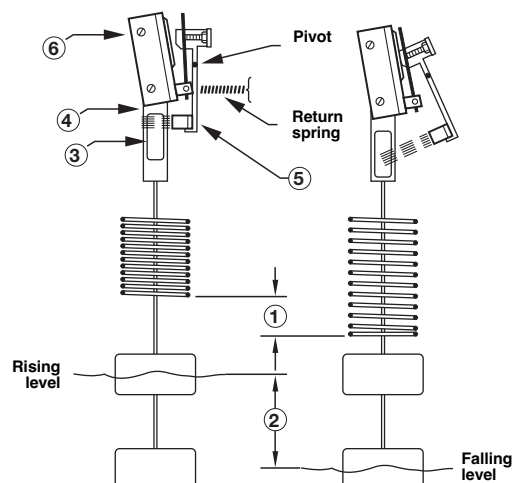

MOUNTING

CAUTION: Displacer spring and stem are fragile. Do not drop displacers into tank. Hand feed cable into position to avoid bending stem.

Adjust the displacers on the displacer cable for the desired switch actuating levels. (Instruction tag attached to cable.) Screw displacer cable fitting to threaded connection link protruding from the underside of control.

Be sure there are no tubes, rods, or other obstacles in the tank or vessel to interfere with the operation of the displacers. No guides into the tank are necessary unless liquid turbulence is excessive, in which case a "guided pipe" or tube should be at least 25 mm larger than the displacer diameter, open at the bottom end and with several vent holes located above the maximum high level of the liquid.

Check installation of pipe or tube to be certain it is plumb.

CAUTION: Before attaching Magnetrol control to tank or vessel, using a level, check to see that tank mounting flange is within 3° of horizontal in all directions. Proper operation of the control depends on the switch housing being plumb.

For floating roof top applications, the displacer switch may be mounted via flange or threaded mounting on a bracket, catwalk, etc. or through an opening in an outer dome roof. Ensure that there are no obstacles to interfere with the operation of the displacers or weights and that there is a level surface on the roof beneath the displacer/weight.

CAUTION: Operation of all buoyancy type level devices should be done in such a way as to minimize the action of dynamic forces on the float or displacer sensing element. Good practice for reducing the likelihood of damage to the control is to equalize pressure across the device slowly.

CAUTION: All units are shipped from the factory with the enclosing tube tightened and the switch housing set screw locked to the enclosing tube. Failure to loosen the set screw prior to repositioning the supply and output connections may cause the enclosing tube to loosen, resulting in possible leakage of the process liquid or vapor.

NOTE: If control is equipped with pneumatic switch mechanism, disregard these instruction and refer to instruction bulletin BE 42-685 and BE 42-686 on mechanism furnished for air (or gas) connections.

The units are shipped with the cable entry of the switch housing placed 90° opposite the tank connections to simplify installation in most cases. If the location of the cable entry on the level switch is appropriate to the installation, proceed to Step 4 to begin wiring the unit. If another configuration is desired, the switch housing can be easily rotated by first following Steps 1, 2, and 3.

1. Loosen set screw(s) at base of switch housing. Refer to Figure 3.
2. Switch housing may be rotated 360° to allow correct positioning of cable entry.
3. Tighten set screw(s) at base of switch housing.
4. Unscrew and remove switch housing cover. The threads have been lubricated to facilitate removal.

CAUTION: DO NOT attempt to unscrew cover of ATEX explosion proof housings before loosening locking screw in cover (Figure 3 - ATEX cast aluminium) or base (Figure 4 - ATEX cast iron) of housing. ALWAYS retighten locking screw after replacing cover.

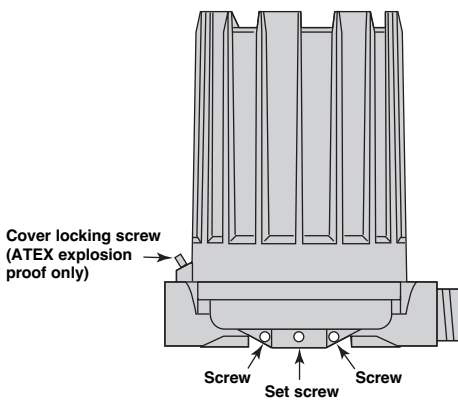

Figure 3
Cast aluminium switch housing

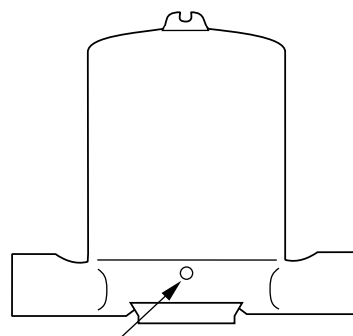

Figure 4
ATEX cast iron switch housing

NOTE: For supply connections use wire with a minimum rating of 75 °C, as required by process conditions. Use a minimum of 14 AWG wire for power and ground field wires. On high temperature applications (above 120 °C [250 °F] at mounting flange or bushing), high temperature wire should be used between control and first junction box located in a cooler area.

5. The switch terminals are located next to the cable entry to facilitate wiring. Bring supply wires through cable entry. Route extra wire around enclosing tube under the baffle plate, and connect them to the proper terminals. Refer to the wiring diagram.
6. Dress wiring to ensure no interference or contact with the switch actuation arm, or replacement of switch housing cover.

NOTE: Observe all applicable electrical codes and proper wiring procedures.

Prevent moisture seepage into the enclosure by installing approved cable glands.

CAUTION: For units with explosion proof housing, do not power the unit until the cable gland is sealed and the enclosure cover is screwed down securely.

7. Replace housing cover and retighten locking screw in case of ATEX explosion proof housing.
8. Test switch action by varying liquid level in the tank or vessel.

NOTE: If switch mechanism fails to function properly, check vertical alignment of control housing and consult installation bulletin on switch mechanisms furnished.

9. Check cover to base fit to be certain gasketed joint is tight. A positive seal is necessary to prevent infiltration of moisture laden air or corrosive gasses into switch housing.

For wiring diagrams, refer to the specific bulletin listed in the chart below:

Switch Series Letter	Description	Bulletin No.
B, C, D, F, O, Q, U, W, X, 8	Dry Contact Switch	BE 42-683
HS	Hermetically Sealed Snap Switch	BE 42-694
V	Inductive Proximity Switch	BE 42-798
J	Bleed Type Pneumatic Switch	BE 42-685
K	Non-Bleed Type Pneumatic Switch	BE 42-686

PREVENTIVE MAINTENANCE

Periodic inspections are a necessary means to keep your level control in good working order. This control is a safety device to protect the valuable equipment it serves. A systematic program of "preventive maintenance" must be implemented when the control is placed into service. If the following sections on "What to do" and "What to avoid" are observed, your control will provide reliable protection of your equipment for many years.

What to do

1. Keep control clean

Be sure the switch housing cover is always in place on the control. This cover is designed to keep dust and dirt from interfering with switch mechanism operation. In addition, it protects against damaging moisture and acts as a safety feature by keeping bare wires and terminals from being exposed. Should the housing cover become damaged or misplaced, order a replacement immediately.

2. Inspect switch mechanisms, terminals and connections regularly

Dry contact switches should be inspected for excessive wear on actuating lever or misalignment of adjustment screw at point of contact between screw and lever. Such wear can cause false switch actuating levels^①.

DO NOT operate your control with defective or maladjusted switch mechanisms^①.

Level controls may sometimes be exposed to excessive heat or moisture. Under such conditions, insulation on electrical wiring may become brittle, eventually breaking or peeling away. The resulting "bare" wires can cause short circuits.

NOTE: Check wiring carefully and replace at the first sign of brittle insulation.

Vibration may sometimes cause terminal screws to loosen. Check all terminal connections to be certain that screws are tight.

On units with pneumatic switches, air (or gas) lines subjected to vibration, may eventually crack or become loose at connections causing leakage. Check lines and connections carefully and repair or replace, if necessary.

NOTE: Spare switches should be kept on hand at all times.

What to avoid

1. **NEVER** leave switch housing cover of the control longer than necessary to make routine inspections.
2. **NEVER** use lubricants on pivots of switch mechanisms. A sufficient amount of lubricant has been applied at the factory to insure a lifetime of service. Further oiling is unnecessary and will only tend to attract dust and dirt which can interfere with mechanism operation.
3. **NEVER** attempt to make adjustments or replace switches without reading instructions carefully. Certain adjustments provided for in Magnetrol controls should not be attempted in the field. When in doubt, consult the factory or your local Magnetrol representative.
4. **NEVER** attempt to readjust magnetic attraction sleeves which are factory set. Tampering may cause failure of control while in service even though manual operation actuates switches.
5. **NEVER** place a jumper wire across terminals to "cut-out" the control. If a "jumper" is necessary for test purposes, be certain it is removed before placing control into service.

^① See switch mechanisms bulletin furnished should switch adjustment or replacement be necessary.

Usually the first indication of improper operation is failure of the controlled equipment to function—pump will not start (or stop), signal lamps fail to light, etc. When these symptoms occur, whether at time of installation or during routing service thereafter, check the following potential external causes first.

- Fuses may be blown.
- Reset button(s) may need resetting.
- Power switch may be open.
- Controlled equipment may be faulty.
- Stem may be bent causing hang-up.
- Wiring (or medium lines) leading to control may be defective.

If a thorough inspection of these possible conditions fails to locate the trouble, proceed next to a check of the control's switch mechanism.

Check switch mechanism

1. Pull disconnect switch or otherwise assure that electrical circuit(s) through the control is deactivated.
2. Remove switch housing cover.
3. Disconnect power wiring from switch assembly.
4. Swing magnet assembly in and out by hand, checking carefully for any sign of binding. Assembly should require minimal force, to move it through its full swing.
5. If binding exists, magnet may be rubbing enclosing tube. If magnet is rubbing, loosen magnet clamp screw and shift magnet position. Retighten magnet clamp screw.
6. If switch magnet assembly swings freely and mechanism still fails to actuate, check installation of control to be certain it is within the specified three (3°) degrees of vertical (use spirit level on side of enclosing tube in two places, 90° apart).
7. Check switch continuity with ohm meter. Replace immediately if found defective.

NOTE: Spare switches should be kept on hand at all times.

8. If switch mechanism is operating satisfactorily, a test of the complete control's performance is the next likely step.

Test control's performance

1. Reconnect power supply and carefully actuate switch mechanism manually (using a non-conductive tool on electrical switch mechanism) to determine whether controlled equipment will operate.

CAUTION: With electrical power "on" care should be taken to avoid contact with switch leads and connections at terminal block.

2. If controlled equipment responds to manual actuation test, trouble may be located in level sensing portion of the control (displacers, spring, stem and magnetic attracting sleeve).

NOTE: Check first to be certain liquid is entering tank or vessel. A valve may be closed or pipe line plugged.

CAUTION: Be certain to pull disconnect switch or otherwise assure that electrical circuit(s) through control is deactivated. Close operating medium supply valve on controls equipped with pneumatic switch mechanisms.

3. With liquid in tank or vessel, proceed to check level sensing action by removing switch housing assembly.
 - A. Disconnect wiring from supply side of switch mechanism(s) and remove electrical conduit or operating medium line connections to switch housing.
 - B. Relieve pressure from tank or vessel and allow unit to cool.
 - C. Remove switch housing assembly by loosening set screw located immediately below housing base.
4. With switch housing assembly removed, inspect attracting sleeve(s) and inside of enclosing tube for excessive corrosion or solids build-up which could restrict movement, preventing sleeve(s) from reaching field of switch magnet(s).
5. Inspect displacer stem and spring assembly to assure it is not damaged. If stem or spring is bent or otherwise damaged, movement of the attraction sleeve inside the e-tube will be restricted, preventing proper function of the control.
6. If trouble is still not located, proceed to remove the entire sensing unit from the tank or vessel by unbolting head flange or unscrewing mounting bushing. Inspect displacer assembly and all internal parts for any signs of damage. Check assembly for binding by supporting head flange or mounting bushing over the edge of a bench and move displacer assembly by hand.

NOTE: When in doubt about the condition or performance of a Magnetrol control, contact the factory or consult your local representative.

TROUBLESHOOTING

Proof-er

If the Proof-er is not functioning properly, listed below are potential problems and corrective action.







1. Proof-er does not return to the down position after it is activated.

CAUSE	REMEDY
Defective return spring.	Replace Spring.
Buildup between the shaft and housing restricting movement.	Clean Proof-er to remove buildup.
Handle stops are not adjusted properly.	Adjust handle stop screws in or out to allow the handle to move to the proper position.

2. Switch will not trip when Proof-er is activated.

CAUSE	REMEDY
The switch mechanism is defective and not the Proof-er.	Check switch mechanism.
Handle stops are not adjusted properly.	Adjust handle stop screws in or out to allow the handle to move to the proper position.

AGENCY APPROVALS

AGENCY	APPROVED MODEL	AREA CLASSIFICATION
ATEX 	All with electric switch mechanism and housing listed as ATEX Ex d	ATEX II 2 G Ex d IIC T6 Gb
	All with electric switch mechanism and housing listed as ATEX Ex ia	ATEX II 1 G Ex ia IIC T6 Ga
FM 	All with electric switch mechanism and housing listed as NEMA 7/9	Class I, Div 1, groups C & D Class II, Div 1, Groups E, F & G
	Consult factory for proper model numbers	Class I, Div 1, groups B, C & D Class II, Div 1, Groups E, F & G
IECEX 	All with electric switch mechanism and housing listed as IECEX Ex d	Ex d IIC T6
	All with electric switch mechanism and housing listed as IECEX Ex ia	Ex ia IIC T6 Ga
CSA 	Consult factory for proper model numbers	Class I, Div 1, groups C & D Class II, Div 1, Groups E, F & G
	Consult factory for proper model numbers	Class I, Div 1, groups B, C & D Class II, Div 1, Groups E, F & G
EAC (Russia, Kazakhstan, Belarus) 	All with electric switch mechanism and housing listed as ATEX Ex d	1Ex d IIC T6 Gb
	All with electric switch mechanism and housing listed as ATEX Ex ia	0Ex ia IIC T4 Ga
LRS 	Lloyds Register of Shipping	Marine approval
CE 	The units are conform to the ATEX directive 2014/34/EU, The PED directive 2014/68/EU and the Low Voltage Directive 2014/35/EU	
Other approvals are available, consult factory for more details		

SPECIFICATIONS

Basic electrical ratings

Voltage	Switch Series and Non-Inductive Ampere Rating										
	B	C	D	F	HS	O	Q	U	W	X	8
120 V AC	15.00	15.00	10.00	2.50	5.00	15.00	15.00	1.00	1.00	0.50	1.00
240 V AC	15.00	15.00	—	—	5.00	15.00	15.00	—	1.00	0.50	—
24 V DC	6.00	6.00	10.00	4.00	5.00	6.00	6.00	1.00	3.00	0.50	3.00
120 V DC	0.50	1.00	10.00	0.30	0.50	1.00	0.50	—	0.50	0.50	—
240 V DC	0.25	0.50	3.00	—	0.25	0.50	0.25	—	—	—	—

Pressure temperature ratings

Process temperature Process pressure (for higher ratings consult factory)	Threaded models Flanged models	<p><u>Porcelain displacers:</u> ^① 55,1 bar @ 40 °C (800 psi @ 100 °F) – for threaded tank connections 260 °C @ 17,2 bar (500 °F @ 250 psi) – for threaded tank connections 96,5 bar @ 40 °C (1400 psi @ 100 °F) – for flanged 600 lbs rated tank connections</p> <p><u>Stainless steel displacers:</u> 49,6 bar @ 40 °C (720 psi @ 100 °F) 260 °C @ 34,5 bar (500 °F @ 500 psi) Flanged models are downrated to the design pressure of the selected flange</p> <p><u>Hollow brass displacers:</u> 6,9 bar @ 40 °C (100 psi @ 100 °F)</p>
	Medium pressure Proof-er® models	8,6 bar @ 150 °C (125 psi @ 300 °F)
	Low pressure Proof-er® models	1,7 bar @ 90 °C (25 psi @ 200 °F)

^① Do not use porcelain displacers on non-vented boiler water condensate systems over 90 °C (200 °F).

SPECIFICATIONS

Model A15 dimensional data and actuating levels in mm (inches)^①

Threaded mounting

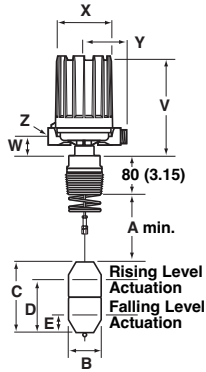

Flanged mounting

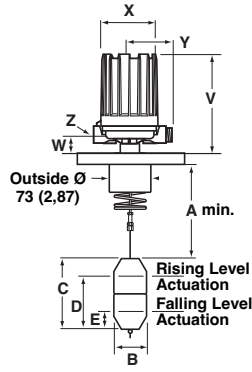

Housing type		V	W	ø X	Y	Z
		mm (inches)	mm (inches)	mm (inches)	mm (inches)	
Weatherproof - FM (NEMA 7/9) - ATEX (Cast Alu)	with HS-switch	257 (10.12)	45 (1.77)	151 (5.93)	109 (4.29)	M20 x 1,5 (*) or 1" NPT (2 entries - 1 plugged) (*) not for FM (NEMA 7/9)
	excl. HS-switch	202 (7.94)				
ATEX (Cast Iron)		249 (9.80)	45 (1.77)	143 (5.63)	110 (4.33)	M20 x 1,5 or 3/4" NPT (single entry - 2 entries at request)
Pneumatics Switch Module J		165 (6.50)	39 (1.54)	118 (4.65)	110 (4.33)	1/4" NPT (1 entry)
Pneumatics Switch Module K		165 (6.50)			130 (5.12)	1/4" NPT (2 entries)

Allow 200 mm (7.87") overhead clearance / All housings are 360 ° rotatable

Outline Dimension A min		
Displacer Type	Threaded Mounting	Flanged Mounting
Porcelain	143 (5.62)	194 (7.62)
Stainless Steel	143 (5.62)	194 (7.62)

Displacer Type	B	C
Porcelain	65 (2.56)	184 (7.25)
Stainless Steel	64 (2.50)	229 (9.00)

Standard actuating levels and liquid specific gravity

Displacer Type	Liquid Temp. ° C (°F)	0.40		0.50		0.60		0.70		0.80		0.90		1.00	
		D	E	D	E	D	E	D	E	D	E	D	E	D	E
Porcelain	+40 (100)	—	—	—	—	129 (5.10)	53 (2.10)	114 (4.50)	43 (1.70)	99 (3.90)	43 (1.70)	88 (3.50)	38 (1.50)	81 (3.20)	35 (1.40)
	+95 (200)	—	—	—	—	142 (5.60)	66 (2.60)	124 (4.90)	53 (2.10)	109 (4.30)	53 (2.10)	96 (3.80)	45 (1.80)	88 (3.50)	43 (1.70)
	+150 (300)	—	—	—	—	—	—	132 (5.20)	60 (2.40)	114 (4.50)	58 (2.30)	104 (4.10)	53 (2.10)	93 (3.70)	48 (1.90)
	+205 (400)	—	—	—	—	—	—	142 (5.60)	71 (2.80)	121 (4.80)	66 (2.60)	109 (4.30)	58 (2.30)	99 (3.90)	53 (2.10)
	+260 (500)	—	—	—	—	—	—	—	—	129 (5.10)	73 (2.90)	116 (4.60)	66 (2.60)	106 (4.20)	60 (2.40)
Stainless Steel	+40 (100)	171 (6.70)	64 (2.50)	137 (5.40)	50 (2.00)	114 (4.50)	40 (1.60)	99 (3.90)	35 (1.40)	86 (3.40)	30 (1.20)	76 (3.00)	27 (1.10)	68 (2.70)	25 (1.00)
	+95 (200)	—	—	152 (6.00)	66 (2.60)	127 (5.00)	53 (2.10)	109 (4.30)	45 (1.80)	93 (3.70)	40 (1.60)	83 (3.30)	35 (1.40)	76 (3.00)	33 (1.30)
	+150 (300)	—	—	162 (6.40)	76 (3.00)	134 (5.30)	60 (2.40)	116 (4.60)	53 (2.10)	101 (4.00)	45 (1.80)	91 (3.60)	43 (1.70)	81 (3.20)	38 (1.50)
	+205 (400)	—	—	175 (6.90)	88 (3.50)	144 (5.70)	71 (2.80)	124 (4.90)	60 (2.40)	109 (4.30)	53 (2.10)	96 (3.80)	48 (1.90)	86 (3.40)	43 (1.70)
	+260 (500)	—	—	—	—	154 (6.10)	81 (3.20)	132 (5.20)	71 (2.80)	116 (4.60)	60 (2.40)	104 (4.10)	55 (2.20)	93 (3.70)	50 (2.00)

Note: All levels ±6 mm (0.25").

Consult factory for other specific gravities

^① See page 24 for Proof-er and/or Floating roof top switch dimensions

SPECIFICATIONS

Model A10 dimensional data and actuating levels in mm (inches)^①

Threaded mounting

Flanged mounting

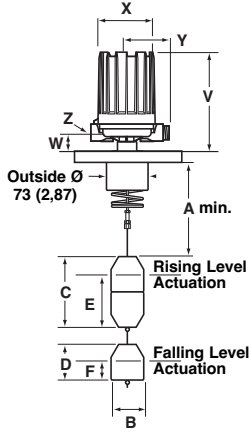
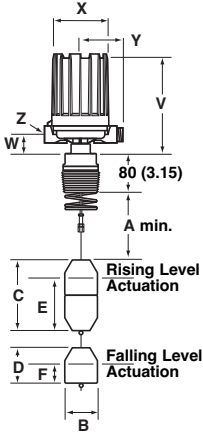

Housing type	V	W	ø X	Y	Z
	mm (inches)	mm (inches)	mm (inches)	mm (inches)	
Weatherproof - FM (NEMA 7/9) - ATEX (Cast Alu)	257 (10.12)	45 (1.77)	151 (5.93)	109 (4.29)	M20 x 1,5 (*) or 1" NPT (2 entries - 1 plugged) (*) not for FM (NEMA 7/9)
ATEX (Cast Iron)	249 (9.80)	45 (1.77)	143 (5.63)	110 (4.33)	M20 x 1,5 or 3/4" NPT (single entry - 2 entries at request)
Pneumatics Switch Module J	216 (8.50)	39 (1.54)	118 (4.65)	110 (4.33)	1/4" NPT (1 entry)
Pneumatics Switch Module K	216 (8.50)			130 (5.12)	1/4" NPT (2 entries)

Allow 200 mm (7.87") overhead clearance / All housings are 360 ° rotatable

Outline Dimension A min		
Displacer Type	Threaded Mounting	Flanged Mounting
Porcelain	127 (5.00)	178 (7.00)
Stainless Steel	121 (4.75)	171 (6.75)

Displacer Type	B	C	D
Porcelain	65 (2.56)	184 (7.25)	92 (3.62)
Stainless Steel	64 (2.50)	229 (9.00)	114 (4.50)

Standard actuating levels and liquid specific gravity

Displacer Type	Liquid Temp. °C (°F)	0.60		0.70		0.80		0.90		1.00	
		E	F	E	F	E	F	E	F	E	F
Porcelain	+40 (100)	134 (5.30)	38 (1.50)	104 (4.10)	30 (1.20)	81 (3.20)	27 (1.10)	63 (2.50)	25 (1.00)	50 (2.00)	22 (0.90)
	+95 (200)	—	—	121 (4.80)	50 (2.00)	96 (3.80)	45 (1.80)	76 (3.00)	40 (1.60)	63 (2.50)	38 (1.50)
	+150 (300)	—	—	—	—	109 (4.30)	60 (2.40)	86 (3.40)	53 (2.10)	73 (2.90)	48 (1.90)
	+205 (400)	—	—	—	—	—	—	86 (3.40)	66 (2.60)	73 (2.90)	60 (2.40)
Stainless Steel	+40 (100)	177 (7.00)	60 (2.40)	134 (5.30)	50 (2.00)	104 (4.10)	45 (1.80)	78 (3.10)	40 (1.60)	60 (2.40)	35 (1.40)
	+95 (200)	—	—	149 (5.90)	71 (2.80)	119 (4.70)	63 (2.50)	91(3.60)	55 (2.20)	71 (2.80)	50 (2.00)
	+150 (300)	—	—	—	—	129 (5.10)	78 (3.10)	101(4.00)	68 (2.70)	81 (3.20)	60 (2.40)
	+205 (400)	—	—	—	—	—	—	111(4.40)	81 (3.20)	91 (3.60)	73 (2.90)
	+260 (500)	—	—	—	—	—	—	—	—	99 (3.90)	83 (3.30)

Note: All levels ±6 mm (0.25").
Consult factory for other specific gravities

^① See page 24 for Proof-er and/or Floating roof top switch dimensions

SPECIFICATIONS

Model B15 dimensional data and actuating levels in mm (inches)^①

Threaded mounting

Flanged mounting

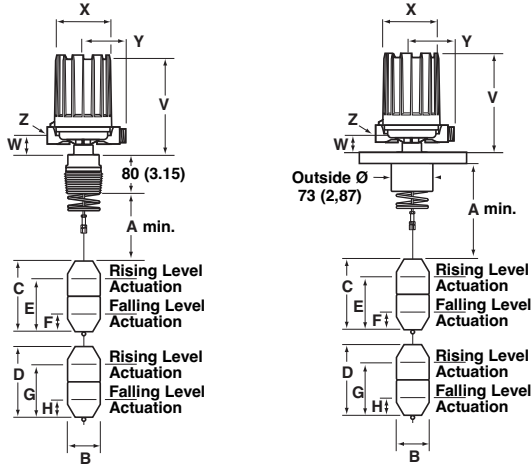

Housing type	V	W	ø X	Y	Z
	mm (inches)	mm (inches)	mm (inches)	mm (inches)	
Weatherproof - FM (NEMA 7/9) - ATEX (Cast Alu)	257 (10.12)	45 (1.77)	151 (5.93)	109 (4.29)	M20 x 1,5 (*) or 1" NPT (2 entries - 1 plugged) (*) not for FM (NEMA 7/9)
ATEX (Cast Iron)	249 (9.80)	45 (1.77)	143 (5.63)	110 (4.33)	M20 x 1,5 or 3/4" NPT (single entry - 2 entries at request)

Allow 200 mm (7.87") overhead clearance / All housings are 360 ° rotatable

Outline Dimensions A min		
Displacer Type	Threaded Mounting	Flanged Mounting
Porcelain	140 (5.50)	191 (7.50)
Stainless Steel	149 (5.88)	200 (7.88)

Displacer Type	B	C	D
Porcelain	65 (2.56)	184 (7.25)	127 (5.00)
Stainless Steel	64 (2.50)	267 (10.50)	152 (6.00)

Standard actuating levels and liquid specific gravity

Displacer Type	Liquid Temp. °C (°F)	0.70				0.80			
		E	F	G	H	E	F	G	H
Stainless Steel	+40 (100)	241 (9.50)	127 (5.00)	124 (4.90)	33 (1.30)	193 (7.60)	93 (3.70)	109 (4.30)	27 (1.10)
	+95 (200)	—	—	—	—	208 (8.20)	109 (4.30)	127 (5.00)	45 (1.80)

Displacer Type	Liquid Temp. °C (°F)	0.95				1.00			
		E	F	G	H	E	F	G	H
Porcelain	+40 (100)	139 (5.50)	50 (2.00)	93 (3.70)	25 (1.00)	127 (5.00)	43 (1.70)	88 (3.50)	20 (0.80)
Stainless Steel	+40 (100)	139 (5.50)	50 (2.00)	93 (3.70)	25 (1.00)	124 (4.90)	43 (1.70)	86 (3.40)	22 (0.90)
	+95 (200)	152 (6.00)	68 (2.70)	106 (4.20)	38 (1.50)	137 (5.40)	55 (2.20)	101 (4.00)	38 (1.50)
	+150 (300)	162 (6.40)	78 (3.10)	119 (4.70)	50 (2.00)	144 (5.70)	63 (2.50)	111 (4.40)	48 (1.90)
	+205 (400)	—	—	—	—	154 (6.10)	73 (2.90)	124 (4.90)	60 (2.40)

Note: All levels ±6 mm (0.25").
Consult factory for other specific gravities

^① See page 24 for Proof-er and/or Floating roof top switch dimensions

SPECIFICATIONS

Model B10 dimensional data and actuating levels in mm (inches)^①

Threaded mounting and displacer arrangement 1

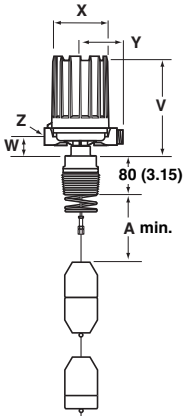

Flanged mounting and displacer arrangement 1

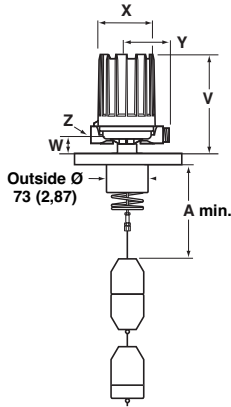

Outline Dimensions A min		
Displacer Type	Threaded Mounting	Flanged Mounting
Porcelain	124 (4.88)	175 (6.88)
Stainless Steel	121 (4.75)	171 (6.75)

Housing type	V	W	ø X	Y	Z
	mm (inches)	mm (inches)	mm (inches)	mm (inches)	
Weatherproof - FM (NEMA 7/9) - ATEX (Cast Alu)	257 (10.12)	45 (1.77)	151 (5.93)	109 (4.29)	M20 x 1,5 (*) or 1" NPT (2 entries - 1 plugged) (*) not for FM (NEMA 7/9)
ATEX (Cast Iron)	249 (9.80)	45 (1.77)	143 (5.63)	110 (4.33)	M20 x 1,5 or 3/4" NPT (single entry - 2 entries at request)

Allow 200 mm (7.87") overhead clearance / All housings are 360 ° rotatable

Model B10 actuating levels – arrangement 1

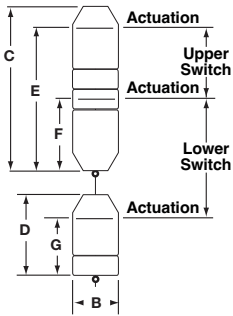

Displacer Type	B	C	D
Porcelain	65 (2.56)	255 (10.04)	127 (5.00)
Stainless Steel	64 (2.50)	305 (12.00)	152 (6.00)

Standard actuating levels and liquid specific gravity with displacer arrangement 1 – porcelain

Displacer Type	Liquid Temp. °C (°F)	Level	0.60 – 0.64	0.65 – 0.71	0.72 – 0.73	0.74 – 0.82	0.83 – 0.92	0.93 – 1.00	1.01 – 1.07
Porcelain	+40 (100)	E	197 – 178 (7.79 – 7.04)	194 – 168 (7.66 – 6.65)	133 – 179 (7.22 – 7.06)	175 – 147 (6.91 – 5.81)	180 – 143 (6.73 – 5.65)	140 – 123 (5.55 – 4.86)	126 – 115 (4.97 – 4.53)
		F	56 – 55 (2.62 – 2.19)	73 – 57 (2.88 – 2.28)	73 – 71 (2.91 – 2.81)	68 – 51 (2.71 – 2.03)	75 – 57 (2.99 – 2.28)	56 – 44 (2.21 – 1.76)	48 – 41 (1.90 – 1.63)
		G	51 – 48 (2.01 – 1.89)	47 – 43 (1.86 – 1.70)	42 – 41 (1.68 – 1.65)	41 – 37 (1.63 – 1.47)	36 – 33 (1.45 – 1.31)	33 – 30 (1.30 – 1.21)	25 – 24 (1.02 – 0.97)
	+95 (200)	E	200 (7.91)	196 – 170 (7.72 – 6.71)	166 – 162 (6.56 – 6.41)	170 – 143 (6.73 – 5.66)	161 – 135 (6.37 – 5.33)	156 – 137 (6.15 – 5.42)	127 – 116 (5.02 – 4.57)
		F	77 (3.06)	74 – 59 (2.95 – 2.34)	57 – 54 (2.25 – 2.16)	64 – 47 (2.54 – 1.87)	66 – 49 (2.63 – 1.95)	71 – 58 (2.81 – 2.32)	49 – 42 (1.94 – 1.67)
		G	70 (2.76)	69 – 63 (2.72 – 2.49)	62 – 61 (2.45 – 2.42)	60 – 54 (2.39 – 2.15)	54 – 48 (2.13 – 1.92)	48 – 44 (1.90 – 1.77)	40 – 37 (1.58 – 1.49)
	+150 (300)	E	—	—	—	189 – 161 (7.48 – 6.34)	178 – 150 (7.04 – 5.93)	171 – 151 (6.75 – 5.98)	141 – 129 (5.57 – 5.10)
		F	—	—	—	83 – 64 (3.29 – 2.55)	83 – 65 (3.30 – 2.56)	86 – 72 (3.41 – 2.87)	63 – 55 (2.50 – 2.19)
		G	—	—	—	79 – 71 (3.14 – 2.83)	71 – 64 (2.80 – 2.53)	63 – 58 (2.50 – 2.32)	54 – 51 (2.13 – 2.01)
	+205 (400)	E	—	—	—	—	—	—	155 – 142 (6.12 – 5.62)
		F	—	—	—	—	—	—	77 – 69 (3.05 – 2.72)
		G	—	—	—	—	—	—	68 – 64 (2.68 – 2.53)

Note: All levels ±6 mm (0.25").

Consult factory for other specific gravities

^① See page 24 for Proof-er and/or Floating roof top switch dimensions

SPECIFICATIONS

Standard actuating levels and liquid specific gravity with displacer arrangement 1 – porcelain

Displacer Type	Liquid Temp. °C (°F)	Level	1.08 – 1.12	1.13 – 1.17	1.18 – 1.27	1.28 – 1.30	1.31 – 1.39	1.40 – 1.50
Porcelain	+40 (100)	E	113 – 106 (4.47 – 4.20)	124 – 117 (4.90 – 4.64)	116 – 102 (4.57 – 4.05)	101 – 98 (3.99 – 3.89)	107 – 97 (4.23 – 3.82)	95 – 84 (3.77 – 3.33)
		F	40 – 36 (1.59 – 1.43)	54 – 50 (2.16 – 1.99)	49 – 40 (1.94 – 1.60)	39 – 38 (1.57 – 1.50)	47 – 40 (1.86 – 1.59)	39 – 32 (1.56 – 1.26)
		G	24 – 23 (0.96 – 0.92)	23 – 22 (0.92 – 0.88)	22 – 20 (0.88 – 0.81)	20 – 20 (0.81 – 0.80)	20 – 18 (0.79 – 0.74)	18 – 17 (0.74 – 0.69)
	+95 (200)	E	118 – 111 (4.66 – 4.39)	109 – 103 (4.33 – 4.08)	109 – 96 (4.32 – 3.81)	108 – 106 (4.29 – 4.18)	104 – 94 (4.13 – 3.73)	99 – 88 (3.93 – 3.47)
		F	45 – 41 (1.79 – 1.62)	40 – 36 (1.58 – 1.43)	42 – 34 (1.69 – 1.36)	47 – 45 (1.87 – 1.80)	44 – 37 (1.76 – 1.49)	43 – 35 (1.71 – 1.40)
		G	37 – 36 (1.48 – 1.42)	35 – 34 (1.41 – 1.36)	34 – 31 (1.35 – 1.25)	31 – 31 (1.24 – 1.23)	30 – 29 (1.22 – 1.15)	28 – 26 (1.14 – 1.06)
	+150 (300)	E	131 – 124 (5.18 – 4.89)	122 – 115 (4.82 – 4.56)	121 – 107 (4.79 – 4.25)	120 – 117 (4.73 – 4.61)	115 – 104 (4.56 – 4.13)	109 – 97 (4.32 – 3.84)
		F	58 – 53 (2.31 – 2.12)	52 – 48 (2.08 – 1.91)	54 – 45 (2.16 – 1.80)	58 – 56 (2.31 – 2.23)	55 – 48 (2.19 – 1.90)	53 – 45 (2.11 – 1.78)
		G	50 – 48 (1.99 – 1.92)	48 – 46 (1.90 – 1.84)	45 – 42 (1.82 – 1.69)	42 – 42 (1.68 – 1.66)	41 – 39 (1.64 – 1.55)	39 – 36 (1.54 – 1.43)
	+205 (400)	E	144 – 136 (5.70 – 5.39)	135 – 128 (5.32 – 5.04)	133 – 119 (5.26 – 4.69)	131 – 128 (5.17 – 5.04)	126 – 115 (4.98 – 4.53)	119 – 107 (4.72 – 4.22)
		F	71 – 66 (2.82 – 2.62)	65 – 60 (2.57 – 2.39)	66 – 56 (2.63 – 2.24)	69 – 67 (2.74 – 2.66)	66 – 58 (2.61 – 2.30)	63 – 54 (2.51 – 2.15)
		G	63 – 61 (2.51 – 2.42)	60 – 58 (2.40 – 2.32)	58 – 54 (2.30 – 2.13)	53 – 52 (2.12 – 2.08)	52 – 49 (2.07 – 1.95)	49 – 45 (1.94 – 1.81)
	+260 (500)	E	157 – 149 (6.22 – 5.89)	147 – 140 (5.81 – 5.52)	145 – 130 (5.74 – 5.13)	142 – 138 (5.60 – 5.47)	137 – 125 (5.41 – 4.93)	130 – 116 (5.12 – 4.59)
		F	84 – 79 (3.34 – 3.12)	77 – 72 (3.07 – 2.86)	78 – 68 (3.11 – 2.68)	80 – 78 (3.18 – 3.09)	77 – 68 (3.04 – 2.70)	73 – 64 (2.91 – 2.52)
		G	76 – 74 (3.03 – 2.92)	73 – 70 (2.89 – 2.79)	70 – 65 (2.77 – 2.57)	64 – 63 (2.55 – 2.51)	63 – 59 (2.50 – 2.35)	59 – 55 (2.33 – 2.18)

Note: All levels ±6 mm (0.25").

Consult factory for other specific gravities

Standard actuating levels and liquid specific gravity with displacer arrangement 1 – stainless steel

Displacer Type	Liquid Temp. °C (°F)	Level	0.50 – 0.58	0.59 – 0.71	0.72 – 0.79	0.80 – 0.85	0.86 – 1.00	1.01 – 1.03
Stainless Steel	+40 (100)	E	251 – 196 (9.91 – 7.72)	233 – 168 (9.19 – 6.62)	214 – 181 (8.44 – 7.16)	194 – 174 (7.66 – 6.86)	170 – 125 (6.71 – 4.93)	122 – 117 (4.82 – 4.61)
		F	86 – 54 (3.46 – 2.16)	94 – 52 (3.72 – 2.08)	100 – 77 (3.96 – 3.07)	92 – 77 (3.63 – 3.07)	75 – 43 (2.96 – 1.71)	41 – 37 (1.63 – 1.48)
		G	63 – 54 (2.51 – 2.16)	54 – 44 (2.13 – 1.77)	44 – 40 (1.74 – 1.59)	39 – 37 (1.57 – 1.48)	37 – 31 (1.46 – 1.25)	31 – 30 (1.24 – 1.22)
	+95 (200)	E	259 – 202 (10.22 – 7.98)	196 – 188 (7.74 – 7.44)	190 – 160 (7.50 – 6.30)	156 – 138 (6.15 – 5.44)	177 – 130 (6.97 – 5.15)	—
		F	95 – 61 (3.76 – 2.42)	57 – 48 (2.27 – 1.89)	76 – 56 (3.02 – 2.22)	53 – 41 (2.12 – 1.64)	81 – 49 (3.22 – 1.93)	—
		G	93 – 80 (3.67 – 3.16)	78 – 65 (3.11 – 2.58)	64 – 58 (2.55 – 2.32)	58 – 54 (2.29 – 2.16)	54 – 46 (2.13 – 1.84)	—
	+150 (300)	E	—	245 – 184 (9.68 – 7.25)	211 – 178 (8.31 – 7.04)	174 – 155 (6.88 – 6.12)	194 – 145 (7.65 – 5.73)	—
		F	—	109 – 68 (4.30 – 2.70)	97 – 75 (3.83 – 2.96)	72 – 58 (2.84 – 2.32)	98 – 63 (3.89 – 2.51)	—
		G	—	102 – 86 (4.03 – 3.40)	85 – 77 (3.36 – 3.06)	76 – 72 (3.02 – 2.84)	71 – 61 (2.81 – 2.42)	—
	+205 (400)	E	—	—	231 – 197 (9.11 – 7.77)	193 – 172 (7.60 – 6.80)	211 – 160 (8.32 – 6.32)	—
		F	—	—	117 – 93 (4.63 – 3.69)	90 – 76 (3.57 – 3.01)	116 – 78 (4.57 – 3.09)	—
		G	—	—	105 – 96 (4.16 – 3.79)	95 – 89 (3.75 – 3.53)	88 – 76 (3.48 – 3.00)	—
	+260 (500)	E	—	—	—	—	228 – 175 (9.00 – 6.90)	—
		F	—	—	—	—	133 – 93 (5.24 – 3.67)	—
		G	—	—	—	—	105 – 90 (4.16 – 3.58)	—

Note: All levels ±6 mm (0.25").

Consult factory for other specific gravities

SPECIFICATIONS

Model B10 actuating levels – arrangement 2

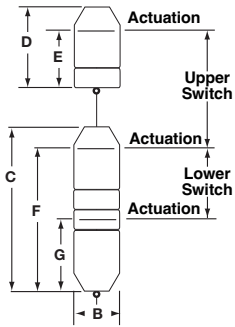

Displacer Type	B	C	D
Porcelain	65 (2.56)	255 (10.04)	127 (5.00)
Stainless Steel	64 (2.50)	305 (12.00)	152 (6.00)

Standard actuating levels and liquid specific gravity with displacer arrangement 2 – stainless steel

Displacer Type	Liquid Temp. °C (°F)	Level	0.50 – 0.58	0.59 – 0.71	0.72 – 0.79	0.80 – 0.85	0.86 – 1.00	1.01 – 1.03
Stainless Steel	+40 (100)	E	95 – 40 (3.77 – 1.60)	104 – 35 (4.10 – 1.38)	112 – 75 (4.43 – 2.97)	24 – 91 (4.58 – 3.60)	86 – 31 (3.42 – 1.26)	28 – 22 (1.13 – 0.88)
		F	240 – 207 (9.46 – 8.16)	246 – 205 (9.72 – 8.08)	252 – 230 (9.96 – 9.07)	244 – 230 (9.63 – 9.07)	227 – 195 (8.96 – 7.71)	193 – 189 (7.63 – 7.48)
		G	94 – 81 (3.73 – 3.21)	123 – 102 (4.86 – 4.04)	151 – 138 (5.97 – 5.44)	153 – 144 (6.05 – 5.69)	143 – 122 (5.63 – 4.84)	121 – 119 (4.79 – 4.70)
	+95 (200)	E	107 – 50 (4.22 – 1.98)	44 – 36 (1.74 – 1.44)	94 – 59 (3.74 – 2.35)	55 – 33 (2.17 – 1.33)	98 – 42 (3.89 – 1.66)	—
		F	247 – 213 (9.76 – 8.42)	210 – 174 (8.27 – 6.88)	229 – 208 (9.02 – 8.22)	206 – 194 (8.12 – 7.64)	234 – 201 (9.22 – 7.93)	—
		G	102 – 88 (4.03 – 3.47)	86 – 62 (3.41 – 2.84)	128 – 116 (5.04 – 4.59)	115 – 108 (4.53 – 4.27)	149 – 128 (5.88 – 5.06)	—
	+150 (300)	E	—	123 – 57 (4.87 – 2.26)	115 – 78 (4.55 – 3.08)	73 – 51 (2.89 – 2.02)	115 – 56 (4.56 – 2.24)	—
		F	—	261 – 220 (10.30 – 8.70)	249 – 227 (9.83 – 8.96)	224 – 211 (8.84 – 8.32)	251 – 216 (9.89 – 8.51)	—
		G	—	140 – 118 (5.52 – 4.66)	148 – 135 (5.84 – 5.33)	133 – 125 (5.26 – 4.95)	166 – 131 (6.56 – 5.64)	—
	+205 (400)	E	—	—	135 – 97 (5.35 – 3.82)	91 – 68 (3.62 – 2.70)	133 – 71 (5.24 – 2.82)	—
		F	—	—	270 – 246 (10.63 – 9.69)	243 – 228 (9.57 – 9.01)	183 – 157 (7.21 – 6.22)	—
		G	—	—	168 – 153 (6.65 – 6.06)	152 – 143 (5.99 – 5.63)	183 – 157 (7.24 – 6.22)	—
	+260 (500)	E	—	—	—	—	150 – 86 (5.91 – 3.41)	—
		F	—	—	—	—	285 – 245 (11.24 – 9.67)	—
		G	—	—	—	—	200 – 172 (7.91 – 6.80)	—

Note: All levels ± 6 mm (0.25").

Consult factory for other specific gravities

SPECIFICATIONS

Standard actuating levels and liquid specific gravity with displacer arrangement 2 – porcelain

Displacer Type	Liquid Temp. °C (°F)	Level	0.60 – 0.64	0.65 – 0.71	0.72 – 0.73	0.74 – 0.82	0.83 – 0.92	0.93 – 1.00	1.01 – 1.07
Porcelain	+40 (100)	E	70 – 51 (2.77 – 2.01)	66 – 41 (2.63 – 1.62)	67 – 63 (2.67 – 2.51)	65 – 36 (2.58 – 1.42)	80 – 49 (3.16 – 1.94)	45 – 26 (1.82 – 1.04)	42 – 31 (1.69 – 1.23)
		F	184 – 173 (7.27 – 6.84)	191 – 176 (7.54 – 6.93)	192 – 189 (7.56 – 7.46)	186 – 169 (7.36 – 6.68)	194 – 176 (7.64 – 6.93)	174 – 162 (6.86 – 6.41)	130 – 124 (5.15 – 4.89)
		G	67 – 64 (2.67 – 2.53)	83 – 77 (3.29 – 3.05)	94 – 93 (3.73 – 3.68)	92 – 84 (3.64 – 3.32)	109 – 99 (4.32 – 3.93)	99 – 92 (3.90 – 3.65)	61 – 58 (2.42 – 2.31)
	+95 (200)	E	80 (3.15)	75 – 49 (2.96 – 1.93)	44 – 41 (1.77 – 1.62)	67 – 37 (2.64 – 1.47)	70 – 40 (2.79 – 1.61)	70 – 49 (2.79 – 1.94)	39 – 28 (1.56 – 1.11)
		F	195 (7.71)	193 – 177 (7.60 – 6.99)	175 – 172 (6.90 – 6.81)	182 – 165 (7.19 – 6.52)	184 – 167 (7.28 – 6.60)	189 – 177 (7.46 – 6.97)	131 – 124 (5.19 – 4.92)
		G	86 (3.40)	85 – 78 (3.36 – 3.10)	77 – 76 (3.07 – 3.03)	87 – 80 (3.46 – 3.16)	100 – 91 (3.96 – 3.61)	114 – 106 (4.50 – 4.21)	62 – 59 (2.46 – 2.35)
	+150 (300)	E	—	—	—	86 – 54 (3.39 – 2.15)	88 – 56 (3.47 – 2.22)	86 – 63 (3.39 – 2.50)	53 – 41 (2.11 – 1.63)
		F	—	—	—	201 – 182 (7.94 – 7.20)	201 – 183 (7.95 – 7.21)	204 – 191 (8.06 – 7.53)	146 – 138 (5.75 – 5.45)
		G	—	—	—	106 – 97 (4.21 – 3.84)	117 – 106 (4.63 – 4.21)	129 – 121 (5.10 – 4.77)	76 – 72 (3.02 – 2.87)
	+205 (400)	E	—	—	—	—	—	—	67 – 54 (2.67 – 2.15)
		F	—	—	—	—	—	—	160 – 151 (6.30 – 5.97)
		G	—	—	—	—	—	—	90 – 86 (3.57 – 3.39)

Note: All levels ±6 mm (0.25").
Consult factory for other specific gravities

Standard actuating levels and liquid specific gravity with displacer arrangement 2 – porcelain

Displacer Type	Liquid Temp. °C (°F)	Level	1.08 – 1.12	1.13 – 1.17	1.18 – 1.27	1.28 – 1.30	1.31 – 1.39	1.40 – 1.50
Porcelain	+40 (100)	E	29 – 22 (1.16 – 0.89)	51 – 44 (2.04 – 1.75)	42 – 27 (1.68 – 1.10)	26 – 23 (1.04 – 0.92)	52 – 39 (2.05 – 1.56)	38 – 24 (1.50 – 0.97)
		F	122 – 118 (4.84 – 4.68)	137 – 133 (5.41 – 5.24)	132 – 123 (5.20 – 4.85)	122 – 120 (4.82 – 4.75)	129 – 122 (5.11 – 4.84)	122 – 114 (4.81 – 4.51)
		G	58 – 56 (2.29 – 2.22)	75 – 73 (2.97 – 2.88)	72 – 68 (2.86 – 2.68)	67 – 66 (2.66 – 2.63)	76 – 72 (3.01 – 2.85)	72 – 67 (2.84 – 2.67)
	+95 (200)	E	42 – 35 (1.68 – 1.38)	33 – 26 (1.31 – 1.05)	43 – 28 (1.71 – 1.13)	44 – 41 (1.75 – 1.62)	39 – 27 (1.56 – 1.09)	38 – 25 (1.53 – 1.00)
		F	128 – 123 (5.04 – 4.88)	122 – 118 (4.84 – 4.68)	125 – 117 (4.94 – 4.62)	130 – 128 (5.12 – 5.05)	127 – 120 (5.01 – 4.75)	125 – 118 (4.96 – 4.65)
		G	63 – 61 (2.49 – 2.41)	60 – 59 (2.39 – 2.33)	66 – 61 (2.60 – 2.44)	73 – 70 (2.97 – 2.93)	73 – 70 (2.91 – 2.76)	75 – 77 (2.99 – 2.82)
	+150 (300)	E	55 – 47 (2.19 – 1.88)	45 – 38 (1.81 – 1.52)	2.19 – 1.57 (55 – 39)	50 – 37 (2.18 – 2.05)	50 – 37 (1.98 – 1.49)	49 – 34 (1.93 – 1.37)
		F	141 – 136 (5.56 – 5.37)	135 – 131 (5.33 – 5.16)	137 – 128 (5.41 – 5.06)	138 – 130 (5.56 – 5.48)	138 – 130 (5.44 – 5.15)	136 – 127 (5.36 – 5.03)
		G	76 – 73 (3.01 – 2.91)	73 – 71 (2.89 – 2.80)	77 – 73 (3.07 – 2.88)	84 – 80 (3.40 – 3.36)	84 – 80 (3.33 – 3.16)	86 – 81 (3.39 – 3.19)
	+205 (400)	E	68 – 60 (2.71 – 2.38)	58 – 50 (2.30 – 2.00)	67 – 51 (2.66 – 2.01)	61 – 48 (2.62 – 2.48)	61 – 48 (2.41 – 1.90)	59 – 44 (2.33 – 1.74)
		F	154 – 149 (6.08 – 5.87)	147 – 143 (5.82 – 5.64)	149 – 139 (5.89 – 5.49)	152 – 150 (5.99 – 5.91)	149 – 140 (5.87 – 5.55)	146 – 137 (5.76 – 5.40)
		G	89 – 86 (3.52 – 3.41)	85 – 83 (3.38 – 3.28)	90 – 84 (3.55 – 3.32)	97 – 96 (3.84 – 3.79)	95 – 90 (3.76 – 3.56)	96 – 90 (3.79 – 3.56)
+260 (500)	E	82 – 73 (3.23 – 2.88)	71 – 62 (2.80 – 2.48)	79 – 62 (3.13 – 2.45)	77 – 73 (3.05 – 2.91)	72 – 58 (2.84 – 2.30)	69 – 53 (2.73 – 2.11)	
	F	167 – 161 (6.59 – 6.37)	160 – 155 (6.32 – 6.12)	161 – 150 (6.36 – 5.93)	163 – 161 (6.43 – 6.34)	159 – 151 (6.29 – 5.95)	156 – 146 (6.16 – 5.77)	
	G	102 – 99 (4.04 – 3.91)	98 – 95 (3.88 – 3.76)	102 – 95 (4.02 – 3.76)	108 – 106 (4.28 – 4.21)	106 – 100 (4.19 – 3.97)	106 – 99 (4.19 – 3.93)	

Note: All levels ±6 mm (0.25").
Consult factory for other specific gravities

SPECIFICATIONS

Model B10 actuating levels – arrangement 3, 4, 5

Arrangement 3

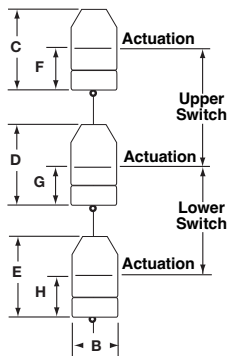

Arrangement 4

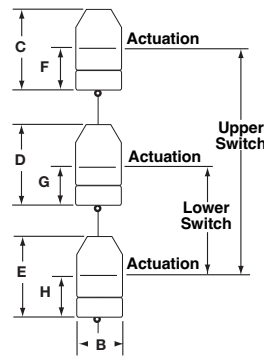

Arrangement 5

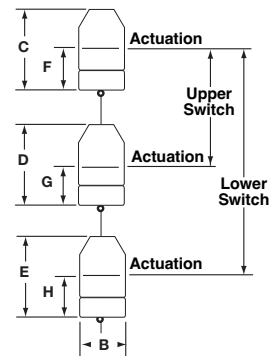

Displacer Type	B	C	D	E
Porcelain	65 (2.56)	127 (5.00)	127 (5.00)	127 (5.00)
Stainless Steel	64 (2.50)	152 (6.00)	152 (6.00)	152 (6.00)

Standard actuating levels and liquid specific gravity with displacer arrangements 3, 4 and 5 – stainless steel

Displacer Type	Liquid Temp. °C (°F)	Level	0.50 – 0.58	0.59 – 0.71	0.72 – 0.79	0.80 – 0.85	0.86 – 1.00	1.01 – 1.03
Stainless Steel	+40 (100)	F	95 – 40 (3.77 – 1.60)	104 – 35 (4.10 – 1.38)	112 – 75 (4.43 – 2.97)	24 – 91 (4.58 – 3.60)	86 – 31 (3.42 – 1.26)	28 – 22 (1.13 – 0.88)
		G	87 – 54 (3.46 – 2.16)	94 – 52 (3.72 – 2.08)	100 – 77 (3.96 – 3.07)	92 – 77 (3.63 – 3.07)	75 – 43 (2.96 – 1.71)	36 – 33 (1.45 – 1.31)
		H	63 – 54 (2.51 – 2.16)	54 – 44 (2.13 – 1.77)	44 – 40 (1.74 – 1.59)	39 – 37 (1.57 – 1.48)	37 – 31 (1.46 – 1.25)	31 – 30 (1.24 – 1.22)
	+95 (200)	F	107 – 50 (4.22 – 1.98)	44 – 36 (1.74 – 1.44)	94 – 59 (3.74 – 2.35)	55 – 33 (2.17 – 1.33)	98 – 42 (3.89 – 1.66)	—
		G	95 – 61 (3.76 – 2.42)	57 – 48 (2.27 – 1.89)	76 – 56 (3.02 – 2.22)	53 – 41 (2.12 – 1.64)	81 – 49 (3.22 – 1.93)	—
		H	93 – 80 (3.67 – 3.16)	78 – 65 (3.11 – 2.58)	64 – 58 (2.55 – 2.32)	58 – 54 (2.29 – 2.16)	54 – 46 (2.13 – 1.84)	—
	+150 (300)	F	—	123 – 57 (4.87 – 2.26)	115 – 78 (4.55 – 3.08)	73 – 51 (2.89 – 2.02)	115 – 56 (4.56 – 2.24)	—
		G	—	109 – 68 (4.30 – 2.70)	97 – 75 (3.83 – 2.96)	72 – 58 (2.84 – 2.32)	98 – 63 (3.89 – 2.51)	—
		H	—	102 – 86 (4.03 – 3.40)	85 – 77 (3.36 – 3.06)	76 – 72 (3.02 – 2.84)	71 – 61 (2.81 – 2.42)	—
	+205 (400)	F	—	—	135 – 97 (5.35 – 3.82)	91 – 68 (3.62 – 2.70)	133 – 71 (5.24 – 2.82)	—
		G	—	—	117 – 93 (4.63 – 3.69)	90 – 76 (3.57 – 3.01)	116 – 78 (4.57 – 3.09)	—
		H	—	—	105 – 96 (4.16 – 3.79)	95 – 89 (3.75 – 3.53)	88 – 76 (3.48 – 3.00)	—
+260 (500)	F	—	—	—	—	150 – 86 (5.91 – 3.41)	—	
	G	—	—	—	—	133 – 93 (5.24 – 3.67)	—	
	H	—	—	—	—	105 – 90 (4.16 – 3.58)	—	

Note: All levels ±6 mm (0.25").
Consult factory for other specific gravities

SPECIFICATIONS

Standard actuating levels and liquid specific gravity with displacer arrangements 3, 4 and 5 – porcelain

Displacer Type	Liquid Temp. °C (°F)	Level	0.60 – 0.64	0.65 – 0.71	0.72 – 0.73	0.74 – 0.82	0.83 – 0.92	0.93 – 1.00	1.01 – 1.07
Porcelain	+40 (100)	F	70 – 51 (2.77 – 2.01)	66 – 41 (2.63 – 1.62)	67 – 63 (2.67 – 2.51)	65 – 36 (2.58 – 1.42)	80 – 49 (3.16 – 1.94)	45 – 26 (1.82 – 1.04)	42 – 31 (1.69 – 1.23)
		G	56 – 45 (2.24 – 1.81)	63 – 48 (2.51 – 1.90)	64 – 61 (2.53 – 2.43)	59 – 42 (2.34 – 1.66)	66 – 48 (2.62 – 1.91)	46 – 35 (1.84 – 1.38)	38 – 32 (1.53 – 1.26)
		H	51 – 48 (2.01 – 1.89)	47 – 43 (1.86 – 1.70)	42 – 41 (1.68 – 1.65)	41 – 37 (1.63 – 1.47)	36 – 33 (1.45 – 1.31)	33 – 30 (1.30 – 1.21)	25 – 24 (1.02 – .097)
	+95 (200)	F	80 (3.15)	75 – 49 (2.96 – 1.93)	44 – 41 (1.77 – 1.62)	67 – 37 (2.64 – 1.47)	70 – 40 (2.79 – 1.61)	70 – 49 (2.79 – 1.94)	39 – 28 (1.56 – 1.11)
		G	68 (2.69)	65 – 49 (2.57 – 1.96)	47 – 45 (1.87 – 1.78)	54 – 38 (2.16 – 1.50)	57 – 40 (2.25 – 1.58)	61 – 49 (2.44 – 1.94)	35 – 28 (1.40 – 1.14)
		H	70 (2.76)	69 – 63 (2.72 – 2.49)	62 – 61 (2.45 – 2.42)	60 – 54 (2.39 – 2.15)	54 – 48 (2.13 – 1.92)	48 – 44 (1.90 – 1.77)	40 – 37 (.58 – 1.49)
	+150 (300)	F	—	—	—	86 – 54 (3.39 – 2.15)	88 – 56 (3.47 – 2.22)	86 – 63 (3.39 – 2.50)	53 – 41 (2.11 – 1.63)
		G	—	—	—	74 – 55 (2.92 – 2.18)	74 – 55 (2.93 – 2.18)	77 – 63 (3.04 – 2.50)	49 – 42 (1.95 – 1.66)
		H	—	—	—	79 – 713 (.14 – 2.83)	71 – 64 (2.80 – 2.53)	63 – 58 (2.50 – 2.32)	54 – 51 (2.13 – 2.01)
	+205 (400)	F	—	—	—	—	—	—	67 – 54 (2.67 – 2.15)
		G	—	—	—	—	—	—	68 – 59 (2.68 – 2.34)
		H	—	—	—	—	—	—	68 – 64 (2.68 – 2.53)

Note: All levels ±6 mm (0.25").
Consult factory for other specific gravities

Standard actuating levels and liquid specific gravity with displacer arrangements 3, 4 and 5 – porcelain

Displacer Type	Liquid Temp. °C (°F)	Level	1.08 – 1.12	1.13 – 1.17	1.18 – 1.27	1.28 – 1.30	1.31 – 1.39	1.40 – 1.50
Porcelain	+40 (100)	F	29 – 22 (1.16 – 0.89)	51 – 44 (2.04 – 1.75)	42 – 27 (1.68 – 1.10)	26 – 23 (1.04 – 0.92)	52 – 39 (2.05 – 1.56)	38 – 24 (1.50 – 0.97)
		G	30 – 26 (1.22 – 1.06)	45 – 40 (1.78 – 1.61)	39 – 31 (1.57 – 1.23)	30 – 28 (1.19 – 1.12)	37 – 30 (1.49 – 1.21)	29 – 22 (1.18 – 0.89)
		H	24 – 23 (0.96 – 0.92)	23 – 22 (0.92 – 0.88)	22 – 20 (0.88 – 0.81)	20 – 20 (0.81 – 0.80)	20 – 18 (0.79 – 0.74)	18 – 17 (0.74 – 0.69)
	+95 (200)	F	42 – 35 (1.68 – 1.38)	33 – 26 (1.31 – 1.05)	43 – 28 (1.71 – 1.13)	44 – 41 (1.75 – 1.62)	39 – 27 (1.56 – 1.09)	38 – 25 (1.53 – 1.00)
		G	36 – 31 (1.42 – 1.25)	30 – 26 (1.21 – 1.06)	33 – 25 (1.31 – 0.99)	38 – 36 (1.50 – 1.42)	35 – 28 (1.39 – 1.12)	33 – 26 (1.33 – 1.03)
		H	37 – 36 (1.48 – 1.42)	35 – 34 (1.41 – 1.36)	34 – 31 (1.35 – 1.25)	31 – 31 (1.24 – 1.23)	30 – 29 (1.22 – 1.15)	28 – 26 (1.14 – 1.06)
	+150 (300)	F	55 – 47 (2.19 – 1.88)	45 – 38 (1.81 – 1.52)	55 – 39 (2.19 – 1.57)	50 – 37 (2.18 – 2.05)	50 – 37 (1.98 – 1.49)	49 – 34 (1.93 – 1.37)
		G	49 – 44 (1.93 – 1.75)	43 – 38 (1.70 – 1.53)	45 – 36 (1.79 – 1.43)	49 – 46 (1.93 – 1.85)	45 – 38 (1.81 – 1.52)	43 – 35 (1.73 – 1.40)
		H	50 – 48 (1.99 – 1.92)	48 – 46 (1.90 – 1.84)	45 – 42 (1.82 – 1.69)	42 – 42 (1.68 – 1.66)	41 – 39 (1.64 – 1.55)	39 – 36 (1.54 – 1.43)
	+205 (400)	F	68 – 60 (2.71 – 2.38)	58 – 50 (2.30 – 2.00)	67 – 51 (2.66 – 2.01)	61 – 48 (2.62 – 2.48)	61 – 48 (2.41 – 1.90)	59 – 44 (2.33 – 1.74)
		G	62 – 57 (2.45 – 2.25)	55 – 51 (2.20 – 2.01)	57 – 47 (2.26 – 1.87)	60 – 57 (2.37 – 2.28)	56 – 23 (2.24 – 1.92)	54 – 44 (2.13 – 1.77)
		H	63 – 61 (2.51 – 2.42)	60 – 58 (2.40 – 2.32)	58 – 54 (2.30 – 2.13)	53 – 52 (2.12 – 2.08)	52 – 49 (2.07 – 1.95)	49 – 45 (1.94 – 1.81)
+260 (500)	F	82 – 73 (3.23 – 2.88)	71 – 62 (2.80 – 2.48)	79 – 62 (3.13 – 2.45)	77 – 73 (3.05 – 2.91)	72 – 58 (2.84 – 2.30)	69 – 53 (2.73 – 2.11)	
	G	75 – 69 (2.97 – 2.75)	68 – 63 (2.69 – 2.49)	69 – 58 (2.73 – 2.31)	71 – 68 (2.80 – 2.71)	67 – 59 (2.67 – 2.33)	64 – 54 (2.53 – 2.15)	
	H	76 – 74 (3.03 – 2.92)	73 – 70 (2.89 – 2.79)	70 – 65 (2.77 – 2.57)	64 – 63 (2.55 – 2.51)	63 – 59 (2.50 – 2.35)	59 – 55 (2.33 – 2.18)	

Note: All levels ±6 mm (0.25").
Consult factory for other specific gravities

SPECIFICATIONS

Model C15 dimensional data

Threaded mounting

Flanged mounting

Outline Dimension A min		
Displacer Type	Threaded Mounting	Flanged Mounting
Porcelain	197 (7.75)	248 (9.75)
Stainless Steel	184 (7.25)	235 (9.25)

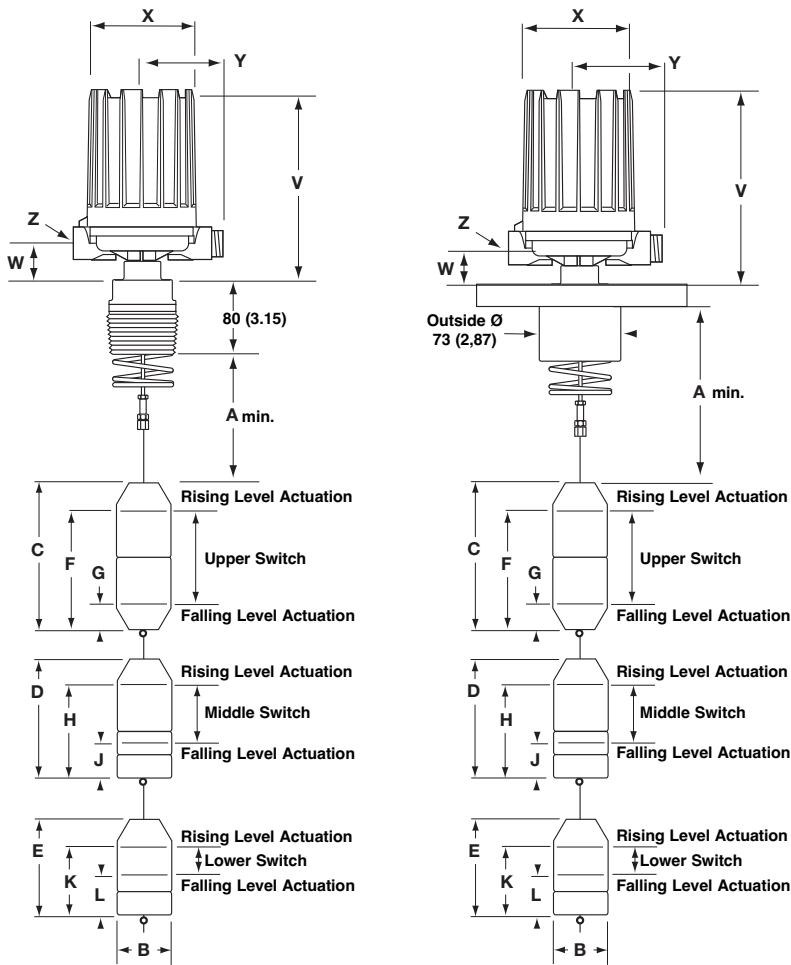

Displacer Type	B	C	D	E
Porcelain	65 (2.56)	184 (7.25)	163 (6.42)	127 (5.00)
Stainless Steel	64 (2.50)	229 (9.00)	191 (7.50)	152 (6.00)

Housing type	V	W	ø X	Y	Z
	mm (inches)	mm (inches)	mm (inches)	mm (inches)	
Weatherproof	376 (14.81)	45 (1.77)	151 (5.93)	109 (4.29)	M20 x 1,5 (*) or 1" NPT (2 entries - 1 plugged) (*) not for FM (NEMA 7/9)

Allow 200 mm (7.87") overhead clearance / All housings are 360 ° rotatable

SPECIFICATIONS

Model C15 actuating levels

Standard actuating levels and liquid specific gravity

Displacer Type	Liquid Temp. °C (°F)	0.65						0.70						0.80					
		F	G	H	J	K	L	F	G	H	J	K	L	F	G	H	J	K	L
Porcelain	0 to +55 (30 to 130)	—	—	—	—	—	—	—	—	—	—	—	—	157 (6.20)	35 (1.40)	134 (5.30)	25 (1.00)	96 (3.80)	22 (0.90)
Stainless Steel	0 to +55 (30 to 130)	195 (7.70)	55 (2.20)	154 (6.10)	50 (2.00)	124 (4.90)	35 (1.40)	170 (6.70)	40 (1.60)	139 (5.50)	40 (1.60)	116 (4.60)	33 (1.30)	165 (6.50)	50 (2.00)	132 (5.20)	40 (1.60)	109 (4.30)	27 (1.10)

Note: All levels ±6 mm (0.25").
Consult factory for other specific gravities

Displacer Type	Liquid Temp. °C (°F)	0.90						1.00						1.10					
		F	G	H	J	K	L	F	G	H	J	K	L	F	G	H	J	K	L
Porcelain	0 to +55 (30 to 130)	157 (6.20)	48 (1.90)	127 (5.00)	35 (1.40)	91 (3.60)	25 (1.00)	116 (4.60)	17 (0.70)	101 (4.00)	20 (0.80)	83 (3.30)	22 (0.90)	106 (4.20)	27 (1.10)	96 (3.80)	25 (1.00)	78 (3.10)	22 (0.90)
Stainless Steel	0 to +55 (30 to 130)	167 (6.60)	66 (2.60)	132 (5.20)	45 (1.80)	101 (4.00)	30 (1.20)	116 (4.60)	25 (1.00)	101 (4.00)	25 (1.00)	91 (3.60)	27 (1.10)	—	—	—	—	—	—

Note: All levels ±6 mm (0.25").
Consult factory for other specific gravities

Displacer Type	Liquid Temp. °C (°F)	1.20						1.25					
		F	G	H	J	K	L	F	G	H	J	K	L
Porcelain	0 to +55 (30 to 130)	4.50 (114)	1.60 (40)	3.70 (93)	1.10 (27)	2.90 (73)	0.90 (22)	3.90 (99)	1.10 (27)	3.30 (83)	0.90 (22)	2.80 (71)	0.80 (20)

Note: All levels ±6 mm (0.25").
Consult factory for other specific gravities

SPECIFICATIONS

Model C10 dimensional data

Threaded mounting

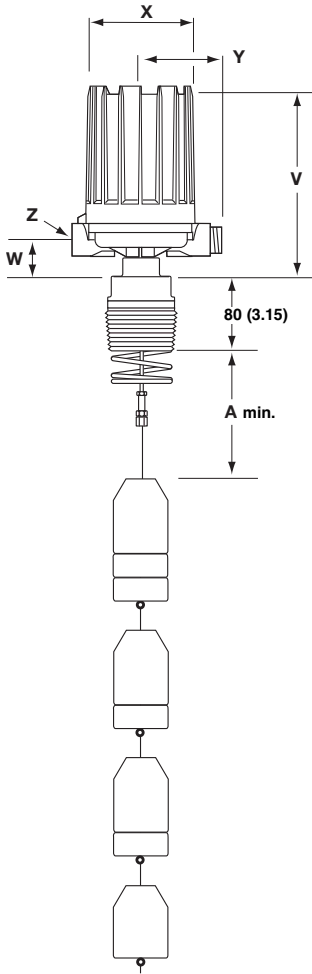

Flanged mounting

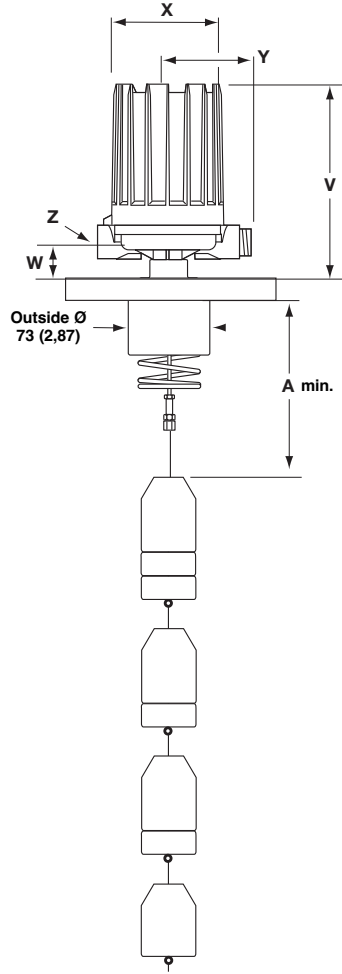

Outline Dimensions A min		
Displacer Type	Threaded Mounting	Flanged Mounting
Porcelain	162 (6.38)	213 (8.38)
Stainless Steel	146 (5.75)	197 (7.75)

Housing type	V	W	ø X	Y	Z
	mm (inches)	mm (inches)	mm (inches)	mm (inches)	
Weatherproof	376 (14.81)	45 (1.77)	151 (5.93)	109 (4.29)	M20 x 1,5 (*) or 1" NPT (2 entries - 1 plugged) (*) not for FM (NEMA 7/9)

Allow 200 mm (7.87") overhead clearance / All housings are 360 ° rotatable

SPECIFICATIONS

Model C10 actuating levels – arrangement A, B, C

Arrangement A

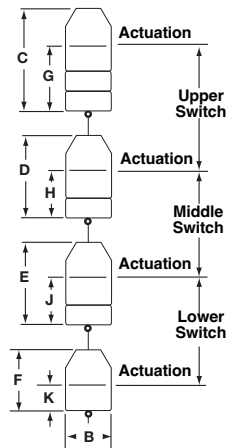

Arrangement B

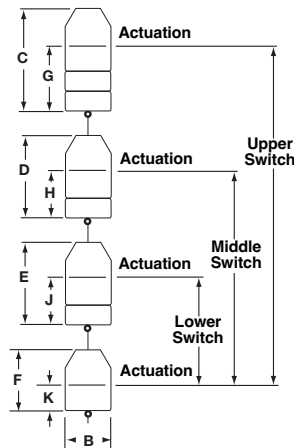

Arrangement C

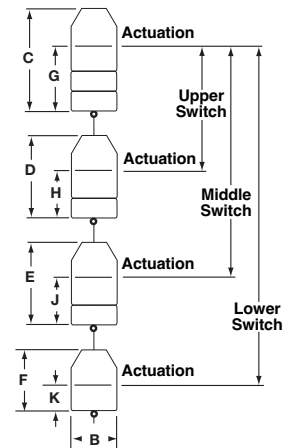

Displacer Type	B	C	D	E	F
Porcelain	65 (2.56)	163 (6.42)	127 (5.00)	127 (5.00)	92 (3.62)
Stainless Steel	64 (2.50)	152 (6.00)	152 (6.00)	114 (4.50)	114 (4.50)

Standard actuating levels and liquid specific gravity

Displacer Type	Liquid Temp. °C (°F)	0.58				0.60				0.70				0.80			
		G	H	J	K	G	H	J	K	G	H	J	K	G	H	J	K
Porcelain	+40 (100)	—	—	—	—	—	—	—	—	63 (2.50)	55 (2.20)	55 (2.20)	50 (2.00)	58 (2.30)	50 (2.00)	48 (1.90)	43 (1.70)
Stainless Steel	+40 (100)	114 (4.50)	93 (3.70)	81 (3.20)	58 (2.30)	96 (3.80)	81 (3.20)	76 (3.00)	55 (2.20)	106 (4.20)	96 (3.80)	53 (2.10)	48 (1.90)	45 (1.80)	55 (2.20)	33 (1.30)	43 (1.70)
	+95 (200)	—	—	—	—	—	—	—	—	—	—	—	—	81 (3.20)	73 (2.90)	63 (2.50)	58 (2.30)

Note: All levels ± 6 mm (0.25").

Consult factory for other specific gravities

Displacer Type	Liquid Temp. °C (°F)	0.90				1.00				1.10				1.20			
		G	H	J	K	G	H	J	K	G	H	J	K	G	H	J	K
Porcelain	+40 (100)	76 (3.0)	61 (2.4)	69 (2.7)	38 (1.5)	36 (1.4)	36 (1.4)	53 (2.1)	36 (1.4)	76 (3.0)	66 (2.6)	64 (2.5)	30 (1.2)	43 (1.7)	43 (1.7)	53 (2.1)	28 (1.1)
	+95 (200)	—	—	—	—	81 (3.2)	69 (2.7)	71 (2.8)	43 (1.7)	43 (1.7)	43 (1.7)	58 (2.3)	41 (1.6)	—	—	—	—
Stainless Steel	+40 (100)	79 (3.1)	81 (3.2)	64 (2.5)	38 (1.5)	33 (1.3)	48 (1.9)	46 (1.8)	33 (1.3)	79 (3.1)	81 (3.2)	64 (2.5)	33 (1.3)	41 (1.6)	56 (2.2)	48 (1.9)	30 (1.2)
	+95 (200)	91 (3.6)	91 (3.6)	43 (1.7)	51 (2.0)	43 (1.7)	58 (2.3)	28 (1.1)	46 (1.8)	—	—	—	—	—	—	—	—
	+150 (300)	86 (3.4)	76 (3.0)	61 (2.4)	69 (2.7)	41 (1.6)	46 (1.8)	43 (1.7)	61 (2.4)	—	—	—	—	—	—	—	—

Note: All levels ± 6 mm (0.25").

Consult factory for other specific gravities

SPECIFICATIONS

Model C10 actuating levels – arrangement D, F

Arrangement D

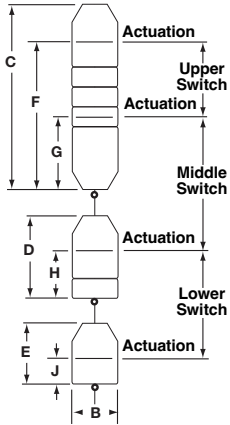

Arrangement F

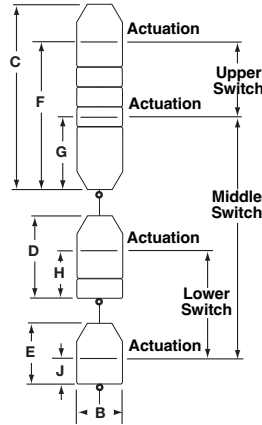

Displacer Type	B	C	D	E
Porcelain	65 (2.56)	367 (14.44)	127 (5.00)	92 (3.62)
Stainless Steel	64 (2.50)	304 (12.00)	114 (4.50)	114 (4.50)

Standard actuating levels and liquid specific gravity

Displacer Type	Liquid Temp. °C (°F)	0.58				0.60				0.70				0.80			
		F	G	H	J	F	G	H	J	F	G	H	J	F	G	H	J
Porcelain	+40 (100)	—	—	—	—	—	—	—	—	190 (7.50)	66 (2.60)	55 (2.20)	50 (2.00)	175 (6.90)	60 (2.40)	48 (1.90)	43 (1.70)
Stainless Steel	+40 (100)	251 (9.90)	93 (3.70)	81 (3.20)	58 (2.30)	233 (9.20)	81 (3.20)	76 (3.00)	55 (2.20)	226 (8.90)	96 (3.80)	53 (2.10)	48 (1.90)	170 (6.70)	55 (2.20)	33 (1.30)	43 (1.70)
	+95 (200)	—	—	—	—	—	—	—	—	—	—	—	—	187 (7.40)	73 (2.90)	63 (2.50)	58 (2.30)

Note: All levels ±6 mm (0.25").
Consult factory for other specific gravities

Displacer Type	Liquid Temp. °C (°F)	0.90				1.00				1.10				1.20			
		F	G	H	J	F	G	H	J	F	G	H	J	F	G	H	J
Porcelain	+40 (100)	167 (6.60)	71 (2.80)	68 (2.70)	38 (1.50)	132 (5.20)	45 (1.80)	53 (2.10)	35 (1.40)	154 (6.10)	76 (3.00)	63 (2.50)	30 (1.20)	127 (5.00)	53 (2.10)	53 (2.10)	27 (1.10)
	+95 (200)	—	—	—	—	157 (6.20)	78 (3.10)	71 (2.80)	43 (1.70)	132 (5.20)	53 (2.10)	58 (2.30)	40 (1.60)	—	—	—	—
Stainless Steel	+40 (100)	182 (7.20)	81 (3.20)	63 (2.50)	38 (1.50)	139 (5.50)	48 (1.90)	45 (1.80)	33 (1.30)	162 (6.40)	81 (3.20)	63 (2.50)	33 (1.30)	132 (5.20)	55 (2.20)	48 (1.90)	30 (1.20)
	+95 (200)	193 (7.60)	91 (3.60)	43 (1.70)	50 (2.00)	149 (5.90)	58 (2.30)	27 (1.10)	45 (1.80)	—	—	—	—	—	—	—	—
	+150 (300)	177 (7.00)	76 (3.00)	60 (2.40)	68 (2.70)	137 (5.40)	45 (1.80)	43 (1.70)	60 (2.40)	—	—	—	—	—	—	—	—

Note: All levels ±6 mm (0.25").
Consult factory for other specific gravities

SPECIFICATIONS

Model C10 actuating levels – arrangement E, G

Arrangement E

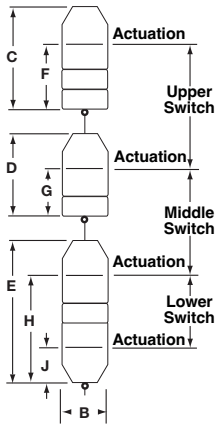

Arrangement G

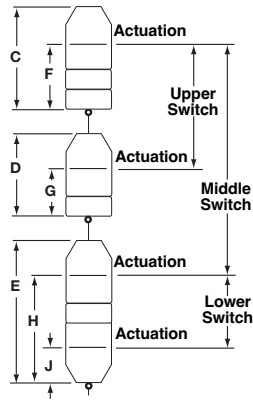

Displacer Type	B	C	D	E
Porcelain	65 (2.56)	163 (6.42)	127 (5.00)	220 (8.65)
Stainless Steel	64 (2.50)	152 (6.00)	152 (6.00)	229 (9.00)

Standard actuating levels and liquid specific gravity

Displacer Type	Liquid Temp. °C (°F)	0.58				0.60				0.70				0.80			
		F	G	H	J	F	G	H	J	F	G	H	J	F	G	H	J
Porcelain	+40 (100)	—	—	—	—	—	—	—	—	63 (2.50)	55 (2.20)	147 (5.80)	48 (1.90)	58 (2.30)	50 (2.00)	139 (5.50)	53 (2.10)
Stainless Steel	+40 (100)	114 (4.50)	93 (3.70)	195 (7.70)	71 (2.80)	96 (3.80)	81 (3.20)	190 (7.50)	68 (2.70)	106 (4.20)	96 (3.80)	167 (6.60)	63 (2.50)	45 (1.80)	55 (2.20)	147 (5.80)	55 (2.20)
	+95 (200)	—	—	—	—	—	—	—	—	—	—	—	—	81 (3.20)	73 (2.90)	177 (7.00)	86 (3.40)

Note: All levels ±6 mm (0.25").

Consult factory for other specific gravities

Displacer Type	Liquid Temp. °C (°F)	0.90				1.00				1.10				1.20			
		F	G	H	J	F	G	H	J	F	G	H	J	F	G	H	J
Porcelain	+40 (100)	76 (3.00)	60 (2.40)	160 (6.30)	81 (3.20)	35 (1.40)	35 (1.40)	144 (5.70)	48 (1.90)	76 (3.00)	66 (2.60)	154 (6.10)	91 (3.60)	43 (1.70)	43 (1.70)	144 (5.70)	86 (3.40)
	+95 (200)	—	—	—	—	81 (3.20)	68 (2.70)	162 (6.40)	91 (3.60)	43 (1.70)	43 (1.70)	149 (5.90)	86 (3.40)	—	—	—	—
Stainless Steel	+40 (100)	78 (3.10)	81 (3.20)	177 (7.00)	96 (3.80)	33 (1.30)	48 (1.90)	160 (6.30)	86 (3.40)	78 (3.10)	81 (3.20)	177 (7.00)	111 (4.40)	40 (1.60)	55 (2.20)	162 (6.40)	101 (4.00)
	+95 (200)	91 (3.60)	91 (3.60)	157 (6.20)	76 (3.00)	43 (1.70)	58 (2.30)	142 (5.60)	68 (2.70)	—	—	—	—	—	—	—	—
	+150 (300)	86 (3.40)	76 (3.00)	175 (6.90)	93 (3.70)	40 (1.60)	45 (1.80)	157 (6.20)	83 (3.30)	—	—	—	—	—	—	—	—

Note: All levels ±6 mm (0.25").

Consult factory for other specific gravities

SPECIFICATIONS

Proof-er® dimensional data

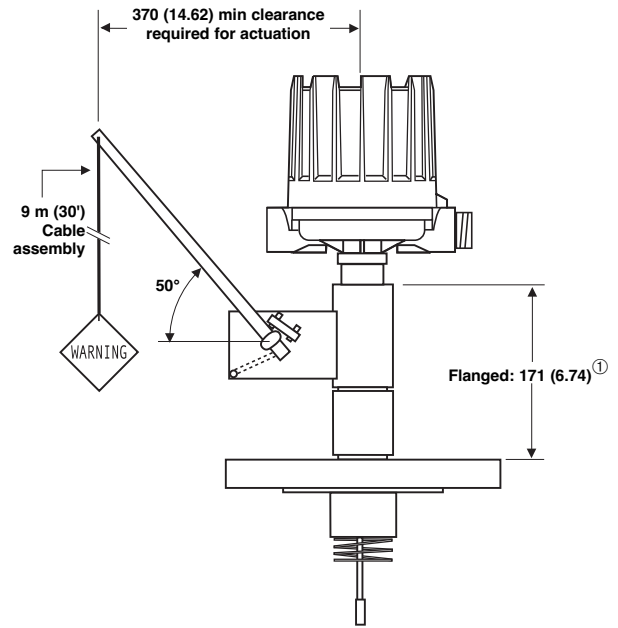
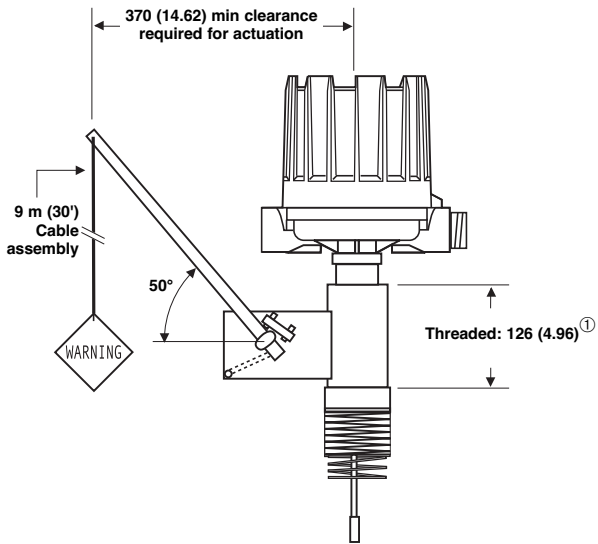

Floating roof of displacers dimensional data

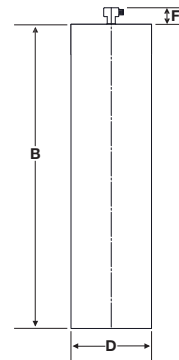
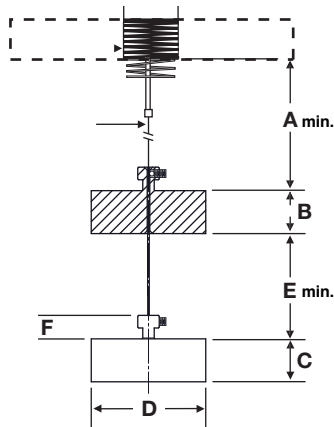

HOLLOW BRASS DISPLACER

		A min	B	C	D	E min	F
A15	Threaded	143 (5.62)	n/a				
	Flanged	194 (7.62)	n/a				
	SS stainless steel	n/a	381 (.50)	n/a	76 (3.00)	n/a	21 (0.82)
	Brass		381 (.50)		73 (2.88)		21 (0.82)
Hollow Brass	229 (9.00)		64 (2.50)		23 (0.92)		
B15	Threaded	149 (5.88)	n/a				
	Flanged	200 (7.88)	n/a				
	SS stainless steel	n/a	38 (1.50)	19 (0.75)	76 (3.00)	102 (4.00)	21 (0.82)
	Brass		28 (1.12)	19 (0.75)	73 (2.88)		21 (0.82)

^① Threaded (126) and Flanged (171) to be added to V-dimension of housing.

REPLACEMENT PARTS

Partn°:

Serial n°:

Digit in partn°: X 1 2 3 4 5 6 7 8 9 10

See nameplate, always provide complete partn° and serial n° when ordering spares.

↳ X = product with a specific customer requirement

CAUTION:

Location of magnetic sleeve(s) must be maintained for proper switch actuation. Do NOT attempt to alter differential of control by repositioning jam nuts.

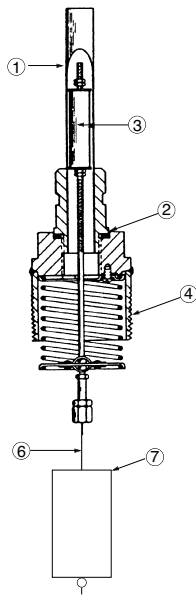

Typical single switch model
(threaded connection)

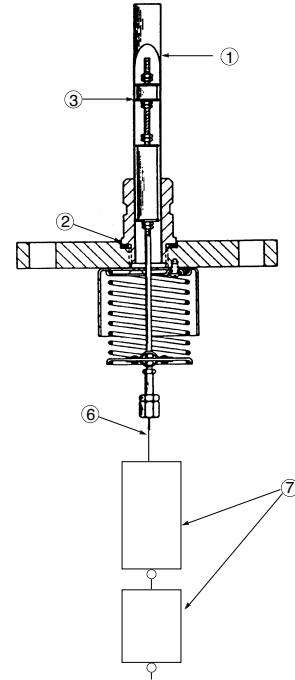

Typical dual switch model
(flanged connection)

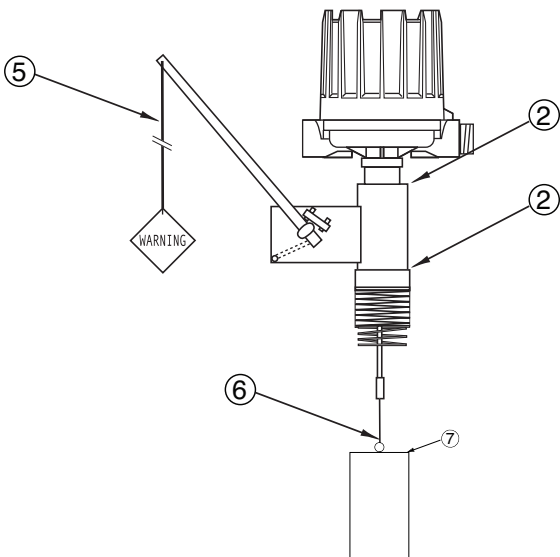

Typical model with Proof-er and floating roof displacer
(threaded connection)

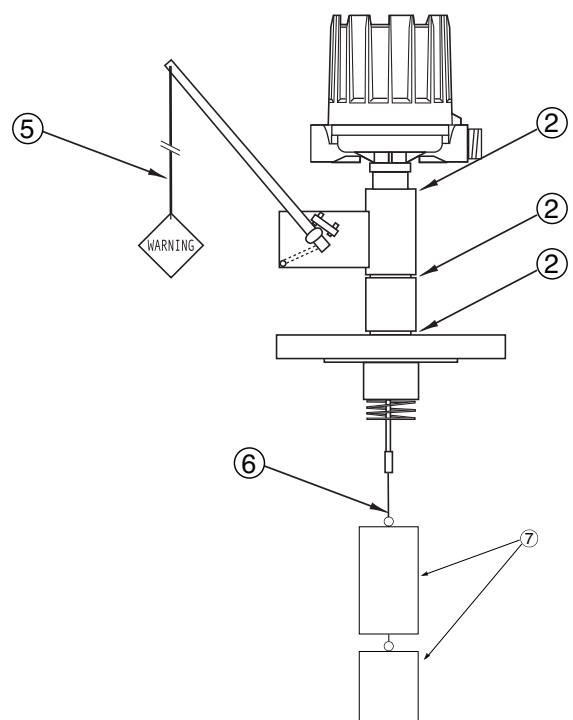

Typical model with Proof-er and floating roof displacer
(flanged connection)

REPLACEMENT PARTS

Switch and housing reference

Switch type	Bulletin
B, C, D, F, O, Q, U, W, X, 8	BE 42-683
HS	BE 42-694
V	BE 42-798
J	BE 42-685
K	BE 42-686
Housing	BE 42-683

(1) Enclosing tube kit (contains items 1 & 2)

Housing type	Replacement part			
	Model (digits 1, 2 & 3)			
	A10	A15	B10 or B15	C10 or C15
Cast aluminium housing for electric switch	089-5933-028	089-5933-027	089-5933-028	089-5959-020
Cast iron housing for electric switch	089-5933-029			not applicable
Pneumatic switch housing	089-5933-028	089-5933-027	not applicable	

	Replacement part
(2) Enclosing tube gasket	012-1204-001
(4) Mounting bushing	consult factory
(5) Proof-er cable kit [cable length = 9 m (30 ft)]	089-5807-001

(3) Spring, stem and attraction sleeve kit

Digit 7	Digit 4	Replacement part					
		Model (digits 1, 2 & 3)					
		A10	A15	B10	B15	C10	C15
A, B	A, E, F	089-5327-001	089-5325-001	consult factory			
	B, D	089-5328-001	089-5326-001				
	K, L	consult factory					
D, E	A, E, F	consult factory	089-5325-002				
	B, D	consult factory					
G, H	A, E, F	consult factory	089-5325-002				
	B, D	consult factory					
M, N, P, Q	A	not applicable	consult factory				
R	A	not applicable	089-5325-001				
T	A	not applicable	089-5325-002				

(6) Cable kit [cable length = 3 m (10 ft)]

Digit 4	Replacement part					
	Model (digits 1, 2 & 3)					
	A10	A15	B10	B15	C10	C15
A, B, D, K or L	089-5802-002	089-5802-001	089-5802-003	089-5802-002	089-5802-004	089-5802-003
E	089-5804-002	089-5804-001	089-5804-003	089-5804-002	089-5804-004	089-5804-003
F	089-5803-002	089-5803-001	089-5803-003	089-5803-002	089-5803-004	089-5803-003

(7) Displacer + cable kit [cable length = 3 m (10 ft)] (contains items 6 & 7)

Digit 4	Digit 7	Replacement part					
		Model (digits 1, 2 & 3)					
		A10	A15	B10	B15	C10	C15
A, B, D, K or L	A, D or G	089-6141-001	089-6142-001	089-6143-001	089-6144-001	089-6153-001	089-6156-001
	B, E or H	089-6149-001	089-6150-001	089-6151-001	089-6152-001	089-6155-001	089-6158-001
	M or N	consult factory		consult factory		not applicable	
	P or Q	not applicable	089-6177-004	not applicable	089-6177-005		
	R or T	089-6177-001		not applicable			
E or F	all	consult factory					

MODEL IDENTIFICATION SINGLE SWITCH MODEL

A complete measuring system consists of:

Order code for **standard** models (each unit is factory calibrated to operate on a given specific gravity within the min and the max values listed per model)

PART NUMBER CODE AND SPECIFIC GRAVITY LIMITS

Part Number Code	Function	Liquid Temp.	Displacer Type	
		°C (°F)	Porcelain	Stainless Steel
A15	One adjustable set point (fixed narrow differential)	40 (100)	0.60 to 2.40	0.40 to 1.65
		95 (200)	0.62 to 2.40	0.40 to 1.65
		150 (300)	0.65 to 2.40	0.50 to 1.65
		200 (400)	0.70 to 2.40	0.55 to 1.65
		260 (500)	0.75 to 2.40	0.60 to 1.65
A10	One adjustable wide differential	40 (100)	0.60 to 1.20	0.60 to 1.20
		95 (200)	0.70 to 1.20	0.70 to 1.20
		150 (300)	0.80 to 1.20	0.80 to 1.20
		200 (400)	1.00 to 1.20	0.90 to 1.20
		260 (500)	1.10 to 1.20	1.00 to 1.20

MATERIALS OF CONSTRUCTION (3 m (10') of suspension cable is standard supplied)

Code	Spring	Trim	Process connections	Displacer clamps and cable	Magnetic sleeve	Construction
A	Inconel 600	316 SST (1.4401)	carbon steel	316 SST (1.4401)	400 series SST	Standard
B	Inconel 600	316 SST (1.4401)	carbon steel	316 SST (1.4401)	316 SST (1.4401)	Standard
D	Inconel 600	316 SST (1.4401)	316 SST (1.4401)	316 SST (1.4401)	316 SST (1.4401)	Standard
E	Inconel 600	316 SST (1.4401)	carbon steel	Monel (2.4360)	400 series SST	Standard
F	Inconel 600	316 SST (1.4401)	carbon steel	Hastelloy C (2.4819)	400 series SST	Standard
K	Inconel X750	316 SST (1.4401)	316 SST (1.4401)	316 SST (1.4401)	316 SST (1.4401)	NACE (not available with Proof-er® option)
L	Inconel X750	316 SST (1.4401)	carbon steel	316 SST (1.4401)	316 SST (1.4401)	NACE (not available with Proof-er® option)

PROCESS CONNECTION
– threaded

E 2	2 1/2" NPT
-----	------------

– ASME flanges

G 3	3" 150 lbs ASME RF
G 4	3" 300 lbs ASME RF
G 5	3" 600 lbs ASME RF
H 3	4" 150 lbs ASME RF
H 4	4" 300 lbs ASME RF
H 5	4" 600 lbs ASME RF
K 3	6" 150 lbs ASME RF
K 4	6" 300 lbs ASME RF

– EN flanges

8 A	DN 80, PN 16	EN 1092-1 Type B1
8 B	DN 80, PN 25/40	EN 1092-1 Type B1
1 A	DN 100, PN 16	EN 1092-1 Type B1
1 B	DN 100, PN 25/40	EN 1092-1 Type B1

DISPLACER MATERIAL AND PROOF-ER® OPTION
(for pressure ratings, refer to physical specifications table)
– without Proof-er®

can be used for NACE

A	Porcelain
B	316 SST (1.4401)

– with low pressure Proof-er®^①

not for NACE

D	Porcelain
E	316 SST (1.4401)

– with medium pressure Proof-er®^①

not for NACE

G	Porcelain
H	316 SST (1.4401)

^① Proof-er® is available in carbon steel only

SWITCH MECHANISM & HOUSING

Refer to table selections per displacer type models A15-A10

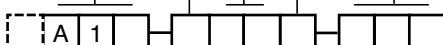

complete code for **standard** models

➔ X = product with a specific customer requirement

MODEL IDENTIFICATION SINGLE SWITCH MODEL

SELECT ELECTRIC SWITCH MECHANISM & HOUSING: MODEL A15

Switch Description	Process ① Temperature Range °C (°F)	Contacts	Weather proof (IP 66)		ATEX - IECEx (IP 66)						FM (IP 66)
					II 2G Ex d IIC T6 Gb				II 1G Ex ia IIC T6 Ga		NEMA 7/9
			Cast Aluminium		Cast Aluminium		Cast Iron (ATEX only)		Cast Aluminium		Cast Alu.
			M20x1,5	1" NPT	M20x1,5	1" NPT	M20x1,5	3/4" NPT	M20x1,5	1" NPT	1" NPT
Series B Snap switch	-40 to +120 (-40 to +250)	1x SPDT	B2Q	BAQ	BH9	BA9	BK5	BU5	–	–	BKQ
		1x DPDT	B8Q	BDQ	BJ9	BB9	BD5	BW5	–	–	BNQ
Series C Snap switch	-40 to +230 (-40 to +450)	1x SPDT	C2Q	CAQ	CH9	CA9	CK5	CU5	C2S	CAS	CKQ
		1x DPDT	C8Q	CDQ	CJ9	CB9	CD5	CW5	C8S	CDS	CNQ
Series D DC Current Snap switch	-40 to +120 (-40 to +250)	1x SPDT	D2Q	DAQ	DH9	DA9	DK5	DU5	–	–	DKQ
		1x DPDT	D8Q	DDQ	DJ9	DB9	DD5	DW5	–	–	DNQ
Series F Hermetically sealed Snap switch	-45 to +260 (-50 to +500)	1x SPDT	F2Q	FAQ	FH9	FA9	FK5	FU5	–	–	FKQ
		1x DPDT	F8Q	FDQ	FJ9	FB9	FD5	FW5	–	–	FNQ
Series HS Hermetically sealed Snap switch	-45 to +260 ② (-50 to +500)	1x SPDT	H7A	HM2	HFC	HA9	HB3	HB4	–	–	HM3
		1x DPDT	H7C	HM6	HGC	HB9	HB7	HB8	–	–	HM7
Series U Gold alloy contacts Snap switch	-40 to +120 (-40 to +250)	1x SPDT	U2Q	UAQ	UH9	UA9	UK5	UU5	U2S	UAS	UKQ
		1x DPDT	U8Q	UDQ	UJ9	UB9	UD5	UW5	U8S	UDS	UNQ
Series V Inductive Proximity switch	-40 to +100 (-40 to +210)	–	–	–	–	–	–	V5S	VBS	–	
Series W Hermetically sealed Silver plated contacts Snap switch	-45 to +230 (-50 to +450)	1x SPDT	W2Q	WAQ	WH9	WA9	WK5	WU5	W2S	WAS	WKQ
		1x DPDT	W8Q	WDQ	WJ9	WB9	WD5	WW5	W8S	WDS	WNQ
Series X Hermetically sealed Gold plated contacts Snap switch	-45 to +230 (-50 to +450)	1x SPDT	X2Q	XAQ	XH9	XA9	XK5	XU5	X2S	XAS	XKQ
		1x DPDT	X8Q	XDQ	XJ9	XB9	XD5	XW5	X8S	XDS	XNQ
Series 8 Hermetically sealed Snap switch	-45 to +260 (-50 to +500)	1x SPDT	82Q	8AQ	8H9	8A9	8K5	8U5	–	–	8KQ
		1x DPDT	88Q	8DQ	8J9	8B9	8D5	8W5	–	–	8NQ

SELECT ELECTRIC SWITCH MECHANISM & HOUSING: MODEL A10

Switch Description	Process ① Temperature Range °C (°F)	Contacts	Weather proof (IP 66)		ATEX - IECEx (IP 66)						FM (IP 66)
					II 2G Ex d IIC T6 Gb				II 1G Ex ia IIC T6 Ga		NEMA 7/9
			Cast Aluminium		Cast Aluminium		Cast Iron (ATEX only)		Cast Aluminium		Cast Alu.
			M20x1,5	1" NPT	M20x1,5	1" NPT	M20x1,5	3/4" NPT	M20x1,5	1" NPT	1" NPT
Series B Snap switch	-40 to +120 (-40 to +250)	1x SPDT	B2B	BAB	BK9	BC9	BK5	BU5	–	–	BKB
		1x DPDT	B8B	BDB	BN9	BF9	BD5	BW5	–	–	BNB
Series C Snap switch	-40 to +230 (-40 to +450)	1x SPDT	C2B	CAB	CK9	CC9	CK5	CU5	C2T	CAT	CKB
		1x DPDT	C8B	CDB	CN9	CF9	CD5	CW5	C8T	CDT	CNB
Series D DC Current Snap switch	-40 to +120 (-40 to +250)	1x SPDT	D2B	DAB	DK9	DC9	DK5	DU5	–	–	DKB
		1x DPDT	D8B	DDB	DN9	DF9	DD5	DW5	–	–	DNB
Series F Hermetically sealed Snap switch	-45 to +260 (-50 to +500)	1x SPDT	FCB	FAB	FK9	FC9	FK5	FU5	–	–	FKB
		1x DPDT	FGB	FDB	FN9	FF9	FD5	FW5	–	–	FNB
Series HS Hermetically sealed Snap switch	-45 to +260 ② (-50 to +500)	1x SPDT	H7A	HM2	HFC	HA9	HB3	HB4	–	–	HM3
		1x DPDT	H7C	HM6	HGC	HB9	HB7	HB8	–	–	HM7
Series U Gold alloy contacts Snap switch	-40 to +120 (-40 to +250)	1x SPDT	U2B	UAB	UK9	UC9	UK5	UU5	U2T	UAT	UKB
		1x DPDT	U8B	UDB	UN9	UF9	UD5	UW5	U8T	UDT	UNB
Series V Inductive Proximity switch	-40 to +100 (-40 to +210)	–	–	–	–	–	–	VCS	VES	–	
Series W Hermetically sealed Silver plated contacts Snap switch	-45 to +230 (-50 to +450)	1x SPDT	W2B	WAB	WK9	WC9	WK5	WU5	W2T	WAT	WKB
		1x DPDT	W8B	WDB	WN9	WF9	WD5	WW5	W8T	WDT	WNB
Series X Hermetically sealed Gold plated contacts Snap switch	-45 to +230 (-50 to +450)	1x SPDT	X2B	XAB	XK9	XC9	XK5	XU5	X2T	XAT	XKB
		1x DPDT	X8B	XDB	XN9	XF9	XD5	XW5	X8T	XDT	XNB
Series 8 Hermetically sealed Snap switch	-45 to +260 (-50 to +500)	1x SPDT	82B	8AB	8K9	8C9	8K5	8U5	–	–	8KB
		1x DPDT	88B	8DB	8N9	8F9	8D5	8W5	–	–	8NB

SELECT PNEUMATIC SWITCH MECHANISM & HOUSING: MODEL A15 – MODEL A10 TYPE DISPLACER SWITCHES

Switch Description	Max supply pressure bar (psi)	Max process temperature ① °C (°F)	Bleed orifice ø mm (inches)	A15 codes		A10 codes	
				NEMA 3R (IP 53)	NEMA 3R (IP 53)	NEMA 3R (IP 53)	NEMA 3R (IP 53)
Series J (open air)	6,9 (100)	200 (400)	1,60 (0.063)	JDE	JGF	JDE	JGF
	4,1 (60)	200 (400)	2,39 (0.094)	JEE	JHF	JEE	JHF
	4,1 (60)	260 (500)	1,40 (0.055)	JFE	JJF	JFE	JJF
Series K (closed circuit)	6,9 (100)	200 (400)	–	KOE	KOF	KOE	KOF

① Process temperature based on max. 40 °C (100 °F) ambient temperature and for non steam applications.

② On steam applications, temperature down-rated to +200 °C (+400 °F) process at +40 °C (+100 °F) ambient.

MODEL IDENTIFICATION DUAL SWITCH MODEL

A complete measuring system consists of:

Order code for **standard** models (each unit is factory calibrated to operate on a given specific gravity within the min and the max values listed per model)

PART NUMBER CODE AND SPECIFIC GRAVITY LIMITS

Part Number Code	Function	Liquid Temp.	Displacer Type	
		°C (°F)	Porcelain	Stainless Steel
B15	Two adjustable set points (fixed narrow differential)	40 (100)	0.95 to 1.20	0.70 to 1.20
		95 (200)	1.10 to 1.20	0.80 to 1.20
		150 (300)	-	0.90 to 1.20
		200 (400)	-	1.00 to 1.20
		260 (500)	-	1.04 to 1.20
B10	Two adjustable wide differentials	40 (100)	0.60 to 1.20	0.50 to 1.00
		95 (200)	0.64 to 1.50	0.50 to 1.00
		150 (300)	0.80 to 1.50	0.60 to 1.00
		200 (400)	1.00 to 1.50	0.72 to 1.00
		260 (500)	1.10 to 1.50	0.84 to 1.00

MATERIALS OF CONSTRUCTION (3 m (10') of suspension cable is standard supplied)

Code	Spring	Trim	Process connections	Displacer clamps and cable	Magnetic sleeve	Construction
A	Inconel 600	316 SST (1.4401)	carbon steel	316 SST (1.4401)	400 series SST	Standard
B	Inconel 600	316 SST (1.4401)	carbon steel	316 SST (1.4401)	316 SST (1.4401)	Standard
D	Inconel 600	316 SST (1.4401)	316 SST (1.4401)	316 SST (1.4401)	316 SST (1.4401)	Standard
E	Inconel 600	316 SST (1.4401)	carbon steel	Monel (2.4360)	400 series SST	Standard
F	Inconel 600	316 SST (1.4401)	carbon steel	Hastelloy C (2.4819)	400 series SST	Standard
K	Inconel X750	316 SST (1.4401)	316 SST (1.4401)	316 SST (1.4401)	316 SST (1.4401)	NACE (not available with Proof-er® option)
L	Inconel X750	316 SST (1.4401)	carbon steel	316 SST (1.4401)	316 SST (1.4401)	

PROCESS CONNECTION - threaded

E 2	2 1/2" NPT
-----	------------

- ASME flanges

G 3	3" 150 lbs ASME RF
G 4	3" 300 lbs ASME RF
G 5	3" 600 lbs ASME RF
H 3	4" 150 lbs ASME RF
H 4	4" 300 lbs ASME RF
H 5	4" 600 lbs ASME RF
K 3	6" 150 lbs ASME RF
K 4	6" 300 lbs ASME RF

- EN flanges

8 A	DN 80, PN 16	EN 1092-1 Type B1
8 B	DN 80, PN 25/40	EN 1092-1 Type B1
1 A	DN 100, PN 16	EN 1092-1 Type B1
1 B	DN 100, PN 25/40	EN 1092-1 Type B1

DISPLACER MATERIAL AND PROOF-ER® OPTION

(for pressure ratings, refer to physical specifications table)

- without Proof-er®

can be used for NACE

A	Porcelain
B	316 SST (1.4401)

- with low pressure Proof-er®^①

not for NACE

D	Porcelain
E	316 SST (1.4401)

^① Proof-er® is available in carbon steel only

SWITCH MECHANISM & HOUSING

Refer to table selections per displacer type models B10-B15 (next page)



complete code for **standard** models

➔ X = product with a specific customer requirement

MODEL IDENTIFICATION DUAL SWITCH MODEL

SELECT ELECTRIC SWITCH MECHANISM AND HOUSING: MODELS B10 & B15

Switch Description	Process ^① Temperature Range °C (°F)	Contacts	Weather proof (IP 66)		ATEX - IECEx (IP 66)						FM (IP 66)
					II 2G Ex d IIC T6 Gb				II 1G Ex ia IIC T6 Ga		NEMA 7/9
			Cast Aluminium		Cast Aluminium		Cast Iron (ATEX only)		Cast Aluminium		Cast Alu.
			M20x1,5	1" NPT	M20x1,5	1" NPT	M20x1,5	3/4" NPT	M20x1,5	1" NPT	1" NPT
Series B Snap switch	-40 to +120 (-40 to +250)	2x SPDT	B4B	BBB	BL9	BD9	BL5	BV5	–	–	BLB
		2x DPDT	B1B	BEB	BP9	BG9	BO5	BY5	–	–	BOB
Series C Snap switch	-40 to +230 (-40 to +450)	2x SPDT	C4B	CBB	CL9	CD9	CL5	CV5	C4T	CBT	CLB
		2x DPDT	C1B	CEB	CP9	CG9	CO5	CY5	C1T	CET	COB
Series D DC Current Snap switch	-40 to +120 (-40 to +250)	2x SPDT	D4B	DBB	DL9	DD9	DL5	DV5	–	–	DLB
		2x DPDT	D1B	DEB	DP9	DG9	DO5	DY5	–	–	DOB
Series F Hermetically sealed Snap switch	-45 to +260 (-50 to +500)	2x SPDT	FFB	FBB	FL9	FD9	FL5	FV5	–	–	FLB
		2x DPDT	FHB	FEB	FP9	FG9	FO5	FY5	–	–	FOB
Series U Gold alloy contacts Snap switch	-40 to +120 (-40 to +250)	2x SPDT	U4B	UBB	UL9	UD9	UL5	UV5	U4T	UBT	ULB
		2x DPDT	U1B	UEB	UP9	UG9	UO5	UY5	U1T	UET	UOB
Series W Hermetically sealed Silver plated contacts Snap switch	-45 to +230 (-50 to +450)	2x SPDT	W4B	WBB	WL9	WD9	WL5	WV5	W4T	WBT	WLB
		2x DPDT	W1B	WEB	WP9	WG9	WO5	WY5	W1T	WET	WOB
Series X Hermetically sealed Gold plated contacts Snap switch	-45 to +230 (-50 to +450)	2x SPDT	X4B	XBB	XL9	XD9	XL5	XV5	X4T	XBT	XLB
		2x DPDT	X1B	XEB	XP9	XG9	XO5	XY5	X1T	XET	XOB
Series 8 Hermetically sealed Snap switch	-45 to +260 (-50 to +500)	2x SPDT	84B	8BB	8L9	8D9	8L5	8V5	–	–	8LB
		2x DPDT	81B	8EB	8P9	8G9	8O5	8Y5	–	–	8OB

^① Process temperature based on max. 40 °C (100 °F) ambient temperature and for non steam applications.

MODEL IDENTIFICATION TRIPLE SWITCH MODEL

Note: Each C10 and C15 instrument is factory calibrated to operate for a given specific gravity within the minimum and maximum values listed.

PART NUMBER CODE AND SPECIFIC GRAVITY LIMITS

Part Number Code	Function	Liquid Temp.	Displacer Type	
		°C (°F)	Porcelain	Stainless Steel
C15	Narrow differential, 3 switches	55 (130)	0.80 to 1.25	0.65 to 1.00
C10	Wide differential, 3 switches	40 (100)	0.65 to 1.20	0.58 to 1.20
		95 (200)	0.95 to 1.10	0.76 to 1.00
		150 (300)	–	0.82 to 1.00

MATERIALS OF CONSTRUCTION (3 m (10') of suspension cable is standard supplied)

Code	Spring	Trim	Process connections	Displacer clamps and cable	Magnetic sleeve	Construction
A	Inconel 600	316 SST (1.4401)	carbon steel	316 SST (1.4401)	400 series SST	Standard
B	Inconel 600	316 SST (1.4401)	carbon steel	316 SST (1.4401)	316 SST (1.4401)	Standard
D	Inconel 600	316 SST (1.4401)	316 SST (1.4401)	316 SST (1.4401)	316 SST (1.4401)	Standard
E	Inconel 600	316 SST (1.4401)	carbon steel	Monel (2.4360)	400 series SST	Standard
F	Inconel 600	316 SST (1.4401)	carbon steel	Hastelloy C (2.4819)	400 series SST	Standard
K	Inconel X750	316 SST (1.4401)	316 SST (1.4401)	316 SST (1.4401)	316 SST (1.4401)	NACE (not available with Proof-er® option)
L	Inconel X750	316 SST (1.4401)	carbon steel	316 SST (1.4401)	316 SST (1.4401)	

PROCESS CONNECTION – threaded

E 2 2 1/2" NPT

– ASME flanges

G 3	3" 150 lbs ASME RF
G 4	3" 300 lbs ASME RF
G 5	3" 600 lbs ASME RF
H 3	4" 150 lbs ASME RF
H 4	4" 300 lbs ASME RF
H 5	4" 600 lbs ASME RF
K 3	6" 150 lbs ASME RF
K 4	6" 300 lbs ASME RF

– EN flanges

8 A	DN 80, PN 16	EN 1092-1 Type B1
8 B	DN 80, PN 25/40	EN 1092-1 Type B1
1 A	DN 100, PN 16	EN 1092-1 Type B1
1 B	DN 100, PN 25/40	EN 1092-1 Type B1

DISPLACER MATERIAL (proof-er® option not available)
(for pressure ratings, refer to physical specifications table)
– without Proof-er®

can be used for NACE

A	Porcelain
B	316 SST (1.4401)

SWITCH MECHANISM & HOUSING

Switch Description	Process ① Temperature Range °C (°F)	Contacts	Weather proof (IP 66)		FM (IP 66)
			Cast Aluminium		NEMA 7/9
			M20 x 1,5	1" NPT	Cast Aluminium 1" NPT
Series O Snap Switch	-40 to +150 ② (-40 to +300)	3x SPDT	O6B	OCB	OMB
		3x DPDT	O1B	OEB	OKB
Series Q Snap Switch	-40 to +120 ② (-40 to +250)	3x SPDT	Q6B	QCB	QMB
		3x DPDT	Q1B	QEB	QKB

① Process temperature based on max. 40 °C (100 °F) ambient temperature and for non steam applications.

② Model C15 limited to 55 °C (130 °F) max.



complete code for **standard models**

X = product with a specific customer requirement

MODEL IDENTIFICATION SINGLE SWITCH FLOATING ROOF MODEL

BASIC MODEL NUMBER – units for ALARM use ONLY

A	1	5	One adjustable set point (fixed narrow differential)
---	---	---	--

MATERIAL OF CONSTRUCTION (3 m (10') of suspension cable is standard supplied)

Code	Spring	Trim	Process connections	Displacer clamps and cable	Magnetic sleeve	Construction
A	Inconel 600	316 SST (1.4401)	carbon steel	316 SST (1.4401)	400 series SST	Standard
B	Inconel 600	316 SST (1.4401)	carbon steel	316 SST (1.4401)	316 SST (1.4401)	Standard
D	Inconel 600	316 SST (1.4401)	316 SST (1.4401)	316 SST (1.4401)	316 SST (1.4401)	Standard

PROCESS CONNECTION – size rating
– threaded

E	2	2 1/2" NPT
---	---	------------

– ASME flanges

G	3	3" 150 lbs ASME RF
G	4	3" 300 lbs ASME RF
H	3	4" 150 lbs ASME RF
H	4	4" 300 lbs ASME RF
K	3	6" 150 lbs ASME RF
K	4	6" 300 lbs ASME RF

– EN flanges

8	A	DN 80, PN 16	EN 1092-1 Type B1
8	B	DN 80, PN 25/40	EN 1092-1 Type B1
1	A	DN 100, PN 16	EN 1092-1 Type B1
1	B	DN 100, PN 25/40	EN 1092-1 Type B1

DISPLACER MATERIAL AND PROOF-ER® OPTION (for pressure ratings, refer to physical specifications table)
– without Proof-er®

P	Brass
R	Hollow brass (roof and liquid) ^①
M	Stainless steel

– with low pressure Proof-er®^②

Q	Brass
T	Hollow brass (roof and liquid) ^①
N	Stainless steel

^① Suitable for process liquids with SG ≥ 0.4.

^② Proof-er® is available in carbon steel only.

SWITCH MECHANISM & HOUSING

Refer to table selections per displacer type model A15 (next page)

A	1	5					
---	---	---	--	--	--	--	--

complete code for floating roof models

X = product with a specific customer requirement

MODEL IDENTIFICATION SINGLE SWITCH FLOATING ROOF MODEL

Switch Description	Process ① Temperature Range °C (°F)	Contacts	Weather proof (IP 66)		ATEX - IECEx (IP 66)						FM (IP 66)
					II 2G Ex d IIC T6 Gb				II 1G Ex ia IIC T6 Ga		NEMA 7/9
			Cast Aluminium		Cast Aluminium		Cast Iron (ATEX only)		Cast Aluminium		Cast Al.
			M20x1,5	1" NPT	M20x1,5	1" NPT	M20x1,5	3/4" NPT	M20x1,5	1" NPT	1" NPT
Series B Snap switch	-40 to +120 (-40 to +250)	1x SPDT	B2Q	BAQ	BH9	BA9	BK5	BU5	–	–	BKQ
		1x DPDT	B8Q	BDQ	BJ9	BB9	BD5	BW5	–	–	BNQ
Series C Snap switch	-40 to +230 (-40 to +450)	1x SPDT	C2Q	CAQ	CH9	CA9	CK5	CU5	C2S	CAS	CKQ
		1x DPDT	C8Q	CDQ	CJ9	CB9	CD5	CW5	C8S	CDS	CNQ
Series D DC Current Snap switch	-40 to +120 (-40 to +250)	1x SPDT	D2Q	DAQ	DH9	DA9	DK5	DU5	–	–	DKQ
		1x DPDT	D8Q	DDQ	DJ9	DB9	DD5	DW5	–	–	DNQ
Series F Hermetically sealed Snap switch	-45 to +260 (-50 to +500)	1x SPDT	F2Q	FAQ	FH9	FA9	FK5	FU5	–	–	FKQ
		1x DPDT	F8Q	FDQ	FJ9	FB9	FD5	FW5	–	–	FNQ
Series HS Hermetically sealed Snap switch	-45 to +260 (-50 to +500)	1x SPDT	H7A	HM2	HFC	HA9	HB3	HB4	–	–	HM3
		1x DPDT	H7C	HM6	HGC	HB9	HB7	HB8	–	–	HM7
Series U Gold alloy contacts Snap switch	-40 to +120 (-40 to +250)	1x SPDT	U2Q	UAQ	UH9	UA9	UK5	UU5	U2S	UAS	UKQ
		1x DPDT	U8Q	UDQ	UJ9	UB9	UD5	UW5	U8S	UDS	UNQ
Series V Inductive Proximity switch	-40 to +100 (-40 to +210)	–	–	–	–	–	–	–	V5S	VBS	–
Series W Hermetically sealed Silver plated contacts Snap switch	-45 to +230 (-50 to +450)	1x SPDT	W2Q	WAQ	WH9	WA9	WK5	WU5	W2S	WAS	WKQ
		1x DPDT	W8Q	WDQ	WJ9	WB9	WD5	WW5	W8S	WDS	WNQ
Series X Hermetically sealed Gold plated contacts Snap switch	-45 to +230 (-50 to +450)	1x SPDT	X2Q	XAQ	XH9	XA9	XK5	XU5	X2S	XAS	XKQ
		1x DPDT	X8Q	XDQ	XJ9	XB9	XD5	XW5	X8S	XDS	XNQ
Series 8 Hermetically sealed Snap switch	-45 to +260 (-50 to +500)	1x SPDT	82Q	8AQ	8H9	8A9	8K5	8U5	–	–	8KQ
		1x DPDT	88Q	8DQ	8J9	8B9	8D5	8W5	–	–	8NQ

SELECT PNEUMATIC SWITCH MECHANISM & HOUSING: MODEL A15 TYPE DISPLACER SWITCHES

Switch Description	Max supply pressure bar (psi)	Max process temperature ① °C (°F)	Bleed orifice ø mm (inches)	A15 codes
				NEMA 3R (IP 53)
Series J (open air)	6,9 (100)	200 (400)	1,60 (0.063)	JDE
	4,1 (60)	200 (400)	2,39 (0.094)	JEE
	4,1 (60)	260 (500)	1,40 (0.055)	JFE
Series K (closed circuit)	6,9 (100)	200 (400)	–	KOE

① Process temperature based on max. 40 °C (100 °F) ambient temperature and for non steam applications.

MODEL IDENTIFICATION DUAL SWITCH FLOATING ROOF MODEL

BASIC MODEL NUMBER – units for ALARM use ONLY

B 1 5	Two adjustable set points (fixed narrow differentials)
-------	--

MATERIAL OF CONSTRUCTION (3 m (10') of suspension cable is standard supplied)

Code	Spring	Trim	Process connections	Displacer clamps and cable	Magnetic sleeve	Construction
A	Inconel 600	316 SST (1.4401)	carbon steel	316 SST (1.4401)	400 series SST	Standard
B	Inconel 600	316 SST (1.4401)	carbon steel	316 SST (1.4401)	316 SST (1.4401)	Standard
D	Inconel 600	316 SST (1.4401)	316 SST (1.4401)	316 SST (1.4401)	316 SST (1.4401)	Standard

PROCESS CONNECTION – size rating
– threaded

E 2	2 1/2" NPT
-----	------------

– ASME flanges

G 3	3" 150 lbs ASME RF
G 4	3" 300 lbs ASME RF
H 3	4" 150 lbs ASME RF
H 4	4" 300 lbs ASME RF
K 3	6" 150 lbs ASME RF
K 4	6" 300 lbs ASME RF

– EN flanges

8 A	DN 80, PN 16	EN 1092-1 Type B1
8 B	DN 80, PN 25/40	EN 1092-1 Type B1
1 A	DN 100, PN 16	EN 1092-1 Type B1
1 B	DN 100, PN 25/40	EN 1092-1 Type B1

DISPLACER MATERIAL AND PROOF-ER® OPTION (for pressure ratings, refer to physical specifications table)
– without Proof-er®

P	Brass
M	Stainless steel

– with low pressure Proof-er®^①

Q	Brass
N	Stainless steel

^① Proof-er® is available in carbon steel only

SWITCH MECHANISM & HOUSING

Refer to table selections per displacer type model B15 (next page)



complete code for floating roof models

→ X = product with a specific customer requirement

MODEL IDENTIFICATION DUAL SWITCH FLOATING ROOF MODEL

SELECT ELECTRIC SWITCH MECHANISM AND HOUSING: MODEL B15

Switch Description	Process ^① Temperature Range °C (°F)	Contacts	Weather proof (IP 66)		ATEX - IECEx (IP 66)						FM (IP 66)
					II 2G Ex d IIC T6 Gb				II 1G Ex ia IIC T6 Ga		NEMA 7/9
			Cast Aluminium		Cast Aluminium		Cast Iron (ATEX only)		Cast Aluminium		Cast Alu.
			M20x1,5	1" NPT	M20x1,5	1" NPT	M20x1,5	3/4" NPT	M20x1,5	1" NPT	1" NPT
Series B Snap switch	-40 to +120 (-40 to +250)	2x SPDT	B4B	BBB	BL9	BD9	BL5	BV5	–	–	BLB
		2x DPDT	B1B	BEB	BP9	BG9	BO5	BY5	–	–	BOB
Series C Snap switch	-40 to +230 (-40 to +450)	2x SPDT	C4B	CBB	CL9	CD9	CL5	CV5	C4T	CBT	CLB
		2x DPDT	C1B	CEB	CP9	CG9	CO5	CY5	C1T	CET	COB
Series D DC Current Snap switch	-40 to +120 (-40 to +250)	2x SPDT	D4B	DBB	DL9	DD9	DL5	DV5	–	–	DLB
		2x DPDT	D1B	DEB	DP9	DG9	DO5	DY5	–	–	DOB
Series F Hermetically sealed Snap switch	-45 to +260 (-50 to +500)	2x SPDT	FFB	FBB	FL9	FD9	FL5	FV5	–	–	FLB
		2x DPDT	FHB	FEB	FP9	FG9	FO5	FY5	–	–	FOB
Series U Gold alloy contacts Snap switch	-40 to +120 (-40 to +250)	2x SPDT	U4B	UBB	UL9	UD9	UL5	UV5	U4T	UBT	ULB
		2x DPDT	U1B	UEB	UP9	UG9	UO5	UY5	U1T	UET	UOB
Series W Hermetically sealed Silver plated contacts Snap switch	-45 to +230 (-50 to +450)	2x SPDT	W4B	WBB	WL9	WD9	WL5	WV5	W4T	WBT	WLB
		2x DPDT	W1B	WEB	WP9	WG9	WO5	WY5	W1T	WET	WOB
Series X Hermetically sealed Gold plated contacts Snap switch	-45 to +230 (-50 to +450)	2x SPDT	X4B	XBB	XL9	XD9	XL5	XV5	X4T	XBT	XLB
		2x DPDT	X1B	XEB	XP9	XG9	XO5	XY5	X1T	XET	XOB
Series 8 Hermetically sealed Snap switch	-45 to +260 (-50 to +500)	2x SPDT	84B	8BB	8L9	8D9	8L5	8V5	–	–	8LB
		2x DPDT	81B	8EB	8P9	8G9	8O5	8Y5	–	–	8OB

^① Process temperature based on max. 40 °C (100 °F) ambient temperature and for non steam applications.

IMPORTANT

SERVICE POLICY

Owners of Magnetrol products may request the return of a control; or, any part of a control for complete rebuilding or replacement. They will be rebuilt or replaced promptly. Magnetrol International will repair or replace the control, at no cost to the purchaser, (or owner) **other than transportation cost** if:

- a. Returned within the warranty period; and,
- b. The factory inspection finds the cause of the malfunction to be defective material or workmanship.

If the trouble is the result of conditions beyond our control; or, is **NOT** covered by the warranty, there will be charges for labour and the parts required to rebuild or replace the equipment.

In some cases, it may be expedient to ship replacement parts; or, in extreme cases a complete new control, to replace the original equipment before it is returned. If this is desired, notify the factory of both the model and serial numbers of the control to be replaced. In such cases, credit for the materials returned, will be determined on the basis of the applicability of our warranty.

No claims for misapplication, labour, direct or consequential damage will be allowed.

RETURNED MATERIAL PROCEDURE

So that we may efficiently process any materials that are returned, it is essential that a "Return Material Authorisation" (RMA) form will be obtained from the factory. It is mandatory that this form will be attached to each material returned. This form is available through Magnetrol's local representative or by contacting the factory. Please supply the following information:

1. Purchaser Name
2. Description of Material
3. Serial Number and Ref Number
4. Desired Action
5. Reason for Return
6. Process details

Any unit that was used in a process must be properly cleaned in accordance with the proper health and safety standards applicable by the owner, before it is returned to the factory.

A material Safety Data Sheet (MSDS) must be attached at the outside of the transport crate or box.

All shipments returned to the factory must be by prepaid transportation. Magnetrol **will not accept** collect shipments.

All replacements will be shipped Ex Works.

UNDER RESERVE OF MODIFICATIONS

BULLETIN: BE 45-610.16
EFFECTIVE: OCTOBER 2019
SUPERSEDES: April 2018

European Headquarters & Manufacturing Facility

Heikensstraat 6

9240 Zele, Belgium

Tel: +32-(0)52-45.11.11 • Fax: +32-(0)52-45.09.93

e-mail: info@magnetrol.be

www.magnetrol.com

