

THERMATEL® MODEL TD1/TD2

Installation and Operating Manual



**Model TD1
with twin tip sensor**



**Model TD2
with spherical tip sensor**

*Thermal Dispersion
Flow/Level/Interface
Switch*



**Model TD2
with low flow body sensor**

UNPACKING

Unpack the instrument carefully. Make sure all components have been removed from the foam protection. Inspect all components for damage. Report any concealed damage to the carrier within 24 hours. Check the contents of the carton/crates against the packing slip and report any discrepancies to Magnetrol. Check the nameplate model number to be sure it agrees with the packing slip and purchase order. Check and record the serial number for future reference when ordering parts.



These units are in compliance with:

1. The EMC directive 2014/30/EU.
2. Directive 2014/34/EU for equipment or protective system intended for use in potentially explosive atmospheres. EC-type examination certificate number ISSeP13ATEX024X or ISSeP13ATEX025X. Standards applied EN60079-0:2012, EN60079-1:2007, EN60079-11:2012 and EN60079-26:2007.

Nameplate:
- partnumber amplifier - sensor
- serial n°
- tag n°



Set up Sticker

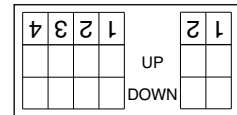

MOUNTING

FLOW

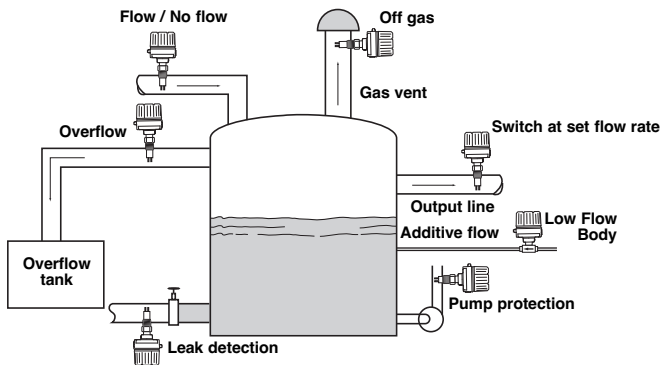

LEVEL

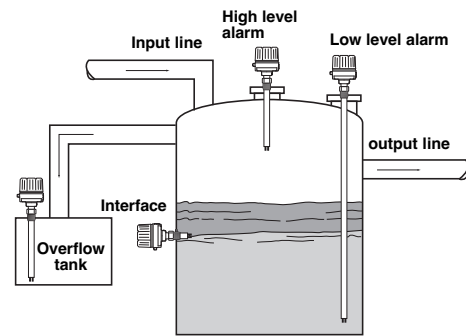

For flow switches calibrated by MAGNETROL, install the probe near the centerline of the pipe. If not calibrated by MAGNETROL, install the probe at least 1/4 diameter depth into the pipe. For best results it is recommended to install the switch with minimum five diameters of straight run upstream and downstream.

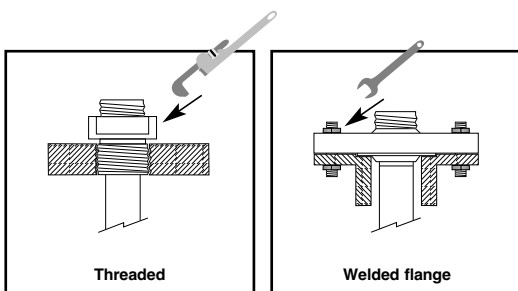
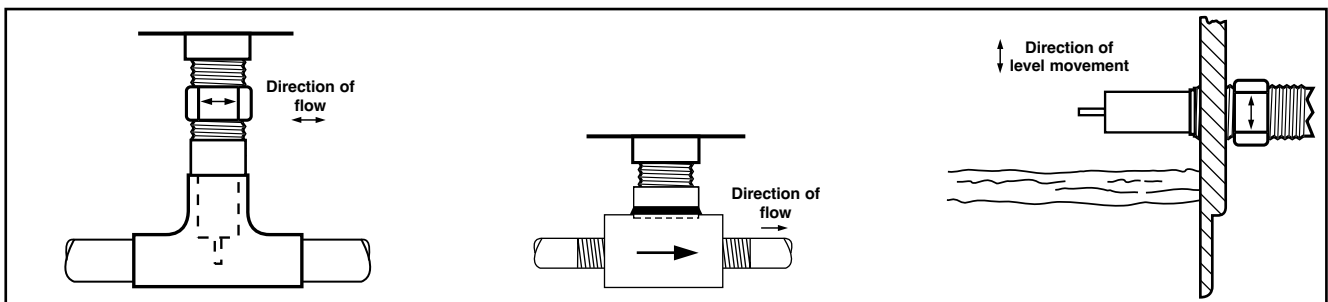

WIRING

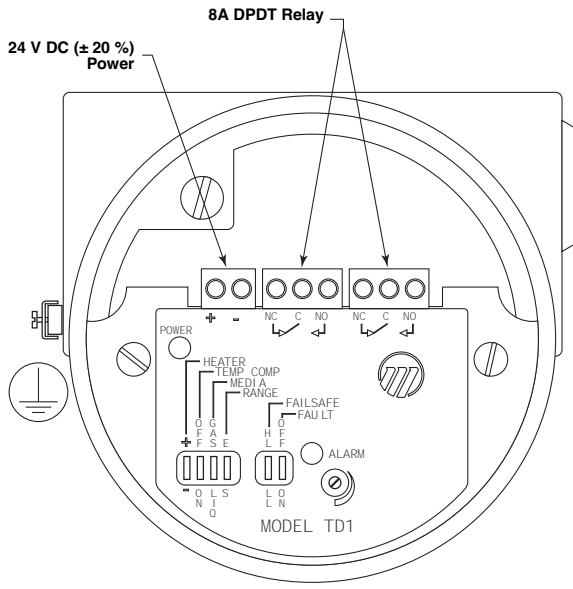

TD1 Wiring

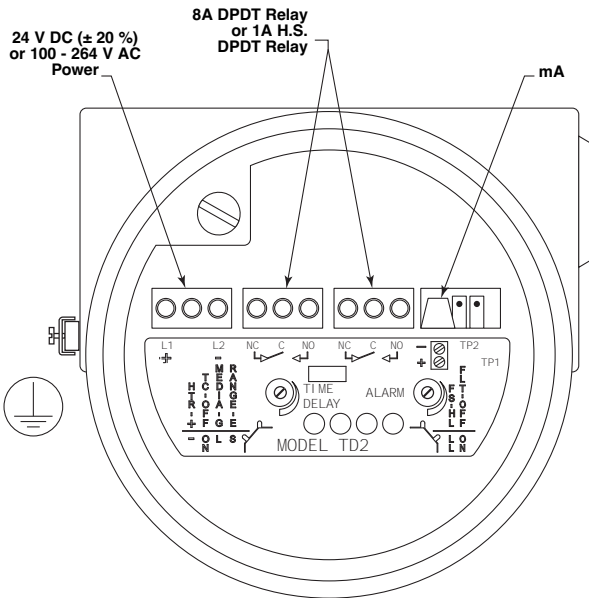

Integral TD2 Wiring

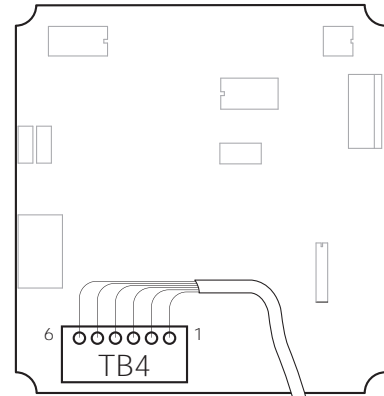

- 1 - white
- 2 - black
- 3 - red
- 4 - green
- 5 - orange
- 6 - blue

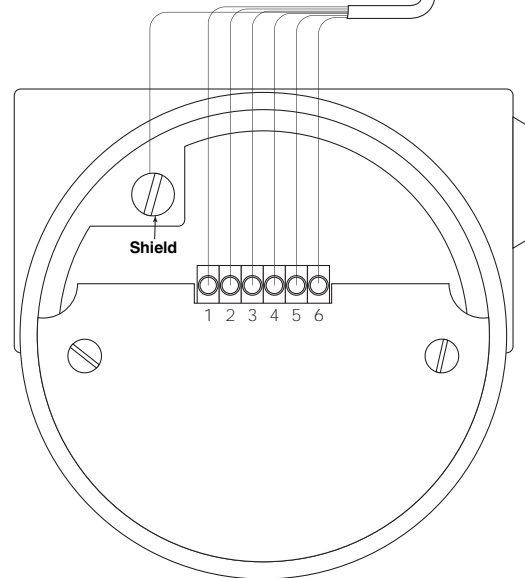

Remote TD2 Wiring

Note: For ATEX II 1G / zone 0: mA signal can only be connected when a Thermatel sensor of 1 mm wall thickness is used.

RELAY CONNECTIONS

Power	Level	Fail-safe position	Relay coil	Relay terminals	
				NC to C	NO to C
On	High	HLFS	De-energized	Closed	Open
		LLFS	Energized	Open	Closed
	Low	HLFS	Energized	Open	Closed
		LLFS	De-energized	Closed	Open
Fail	High	HLFS	De-energized	Closed	Open
		LLFS	De-energized	Closed	Open
	Low	HLFS	De-energized	Closed	Open
		LLFS	De-energized	Closed	Open

CHART NOTES AND DEFINITIONS:

1. Equipment controlled by Thermatel® relays is assumed to be powered from one source, while the Thermatel® unit itself is assumed to be powered from a different source.
2. "Fail" means a loss of power to the Thermatel® unit.
3. HLFS (High Level Fail-safe) means a flow rate or level which is equal to or above the set point.
4. LLFS (Low Level Fail-safe) means a flow rate or level which is equal to or below the set point.
5. When the relay coil is de-energized, a connection is made between the terminals COM (common) and NC (normally closed), and there is no connection between COM and NO (normally open).
6. When the relay coil is energized, a connection is made between the terminals COM and NO, and there is no connection between COM and NC.

Indication and functions

MODEL TD1

POWER LED
Unit powered = green LED on

ALARM LED
Red LED on = alarm
Red LED blinks = error

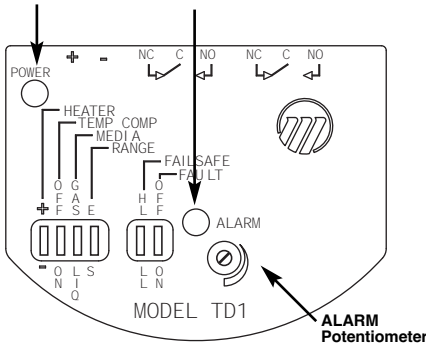

Note: during initial power-on, red LED will blink slowly.

MODEL TD2

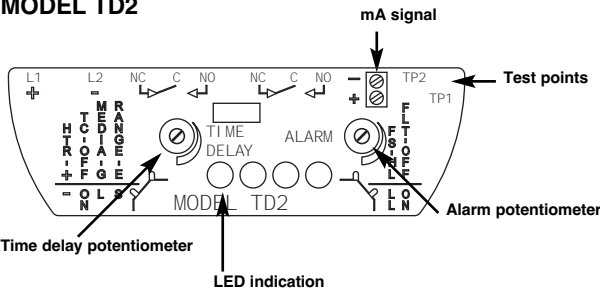

Note: during initial power-on, all LED's will turn on and individually OFF = unit ready.

ALARM (TD1/TD2)



FAIL-SAFE (TD1/TD2):

HLFS (High Level Fail-safe):
Relay is energized when flow < setpoint or sensor dry (or in the low conductive liquid).

Relay is de-energized when flow ≥ setpoint or sensor is immersed (or in the higher conductive liquid).

LLFS (Low Level Fail-safe):

Relay is energized when flow > setpoint or sensor is immersed (or in the higher thermal conductive liquid).

Relay is de-energized when flow ≤ setpoint or sensor dry (or in the lower thermal conductive liquid).

mA SIGNAL (TD2):

The mA is a non linear signal of the actual process conditions;
- for flow: mA output increases as the flow rate increases
- for level: mA output increases when in a wet condition.
The mA value depends upon sensor and application.

Error reporting is determined by setting of the Fail Safe mode;
- failsafe low ≤ 3,6 mA
- failsafe high ≥ 22 mA

TESTPOINTS (TD2):

Measure and record the voltage between TP1 and TP2. This voltage will change as the set point potentiometer is adjusted. Voltage readings will be between 0 and 5 VDC. This value may be used for future reference or adjustment of set point. This value can be recorded and checked in the future to ensure that the set point has not changed since last calibration.

TIME DELAY POTENTIOMETER (TD2):

Before calibration, turn fully counterclockwise until click (max. 30 turns) = 0 s.

LED INDICATION (TD1/TD2):

(in accordance with fail-safe mode)

- green LED ON = safe (one or more of the 2 green LED's) (TD2)
- yellow LED ON = reaching switch point (TD2)
- Red LED ON = alarm (TD1/TD2)
- LED BLINKS = error (TD1/TD2).

Switch setup

For factory calibrated devices, the switch setup and calibration is completed by MAGNETROL for optimal performance in your application. The dip-switch settings and/or potentiometers should only be adjusted for troubleshooting purposes if the factory calibration was not sufficient.

The TD1/TD2 switch settings are pre-set from factory. The factory default settings are marked on the sticker on the electronics. These positions may need to be changed, depending upon the application – consult the following table.

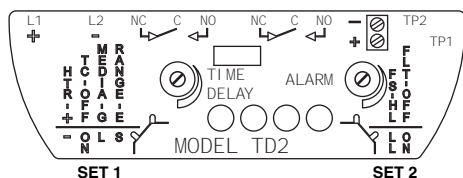
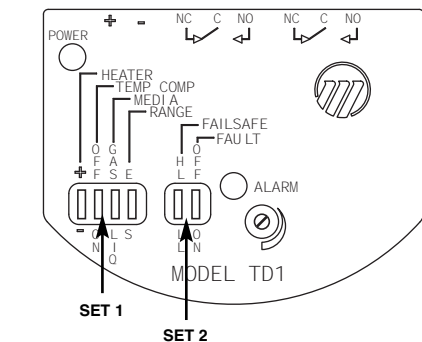
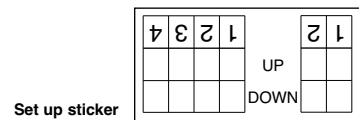

SET 1

TD1/TD2	Purpose	Settings
HEATER / HTR (4)	Control heat to sensor	+ for flow applications - for level applications
TEMP COMP / TC (3)	De-activate temperature compensation	OFF: use only in case recommended by factory ON: default setting
MEDIA (2)	Gas or Liquid	G: Gases L: Liquids, default setting for TMH/TML sensors
RANGE (1)	Sensitivity	S: default setting

SET 2

TD1/TD2	Purpose	Settings
FAILSAFE / FS (2)	Failsafe setting	HL: High Level Fail-safe LL: Low Level Fail-safe
FAULT / FLT (1)	De-activate fault indication	OFF: use only in case recommended by factory ON: default setting

CALIBRATION

For factory calibrated devices, the switch setup and calibration is completed by MAGNETROL for optimal performance in your application. The dip-switch settings and/or potentiometers should only be adjusted for troubleshooting purposes if the factory calibration was not sufficient.

NOTE: Ensure that settings on page 3 have been verified before calibrating this unit. Adjust level, interface or flow to the desired alarm condition of the actual liquid or gas. Units are preferably field calibrated under operating conditions or bench calibrated if the real conditions can be simulated. Consult factory when this cannot be established.

High flow / High level - Interface

High Level Adjustment (High Level Fail-safe)

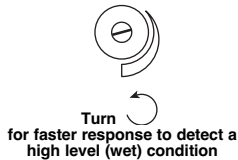

High Flow Adjustment (High Level Fail-safe)

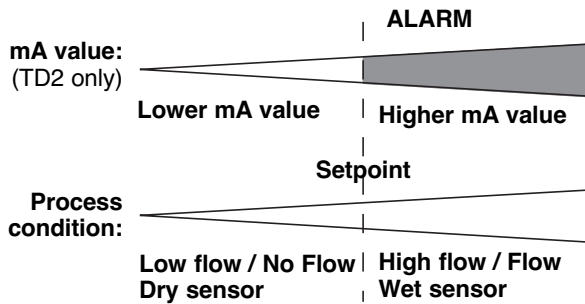
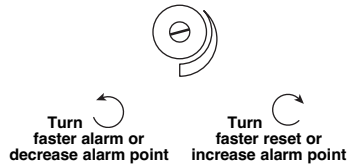

LED indication: ○ ○ ● ●
G G Y R

1. Set Time delay to minimum (turn max 30 turns counterclockwise or until a clicking sound is heard) - only TD2.
2. Set Failsafe switch in "High" mode.
3. Set Alarm potentiometer until red LED is ON. Allow some time for the switch to stabilize (check mA output - only TD2).

Relay will be de-energized, if flow or level is higher than the actual set point or the unit sees the most thermal conductive media.

4. Reset Alarm potentiometer until Red LED is OFF and both green LED's (only TD2) light UP (turn clockwise) – tweak the potentiometer slowly back and forth until the desired set point is reached = Red LED ON.
5. Only for level applications: turn alarm potentiometer counterclockwise one additional turn.

Typical response time for level is within 3 - 5 s.

Typical response time for flow is within 2 - 15 s, depending on the application.

Low flow / No flow / Low level - Interface

Low Level Adjustment (Low Level Fail-safe)

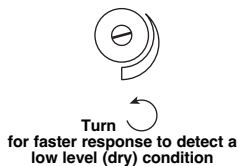

Low Flow Adjustment (Low Level Fail-safe)

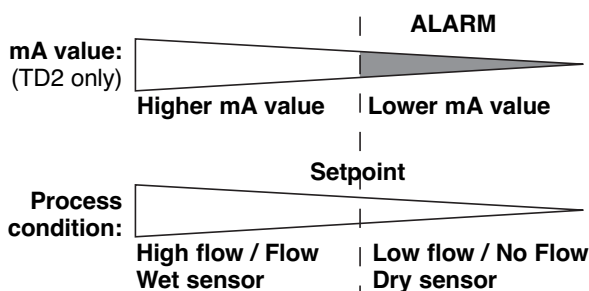
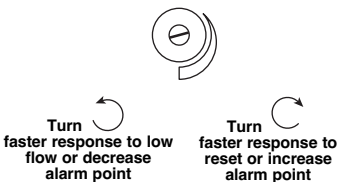

LED indication: ○ ○ ● ●
G G Y R

1. Set Time delay to minimum (turn max 30 turns counterclockwise or until a clicking sound is heard) - only TD2.
2. Set Failsafe switch in "Low" mode
3. Set Alarm potentiometer until: (turn counterclockwise) red LED is ON. Allow some time for the switch to stabilize (check mA output - only TD2).

Relay will be de-energized, if flow or level is lower than the actual set point or the unit sees the least thermal conductive media.

4. Reset Alarm potentiometer until Red LED is OFF and both green LED's (only TD2) light UP (turn clockwise) – tweak the potentiometer slowly back and forth until the desired set point is reached = Red LED ON.
5. Only for level applications: turn alarm potentiometer clockwise 1/2 additional turn.

Typical response time for level is within 5 - 10 s.

Typical response time for flow is within 2 - 15 s, depending on the application.

FAULT INDICATION

TD1/TD2 have continuous diagnostics to ensure that the signal from the sensor is within a select range. If the electronics detect an “out of range” signal, the switch has registered an instrument error.

TD1: Alarm LED blinks and the relay de-energizes.

TD2: 3,6 mA signal when unit is set for low level fail-safe.
22 mA signal when unit is set for high level fail-safe.
Alarm LED blinks and the relay de-energizes.

If a fault is detected, refer to section “TROUBLESHOOTING”.

TROUBLESHOOTING

The TD1/TD2 switches have various settings to handle a wide variety of flow and level applications. If the switch is not performing properly, check the switch settings on page 4 or the following:

Symptom	Problem	Solution / Action
Red LED does not go ON	Switch point cannot be established for air flow detection	Check whether probe is extended into the flow. Change Heater to “-”
Green LED OFF (TD1) All LED's OFF (TD2)	No power	1. Check power supply 2. Check wiring at wiring terminals
Red LED blinks and $\leq 3,6$ mA or ≥ 22 mA (TD2)	An instrument error has been registered	By changing the switch settings, the unit may return to normal operation mode. If not, consult factory.

Symptom	Application	Action*
Unable to adjust set point to obtain alarm Fault LED blinks	Air Flow Detection	Ensure that the probe is extended into the flow Change HEATER (Model TD1) / HTR (Model TD2) to “-”
Switch indicates a fault (red LED will blink)	Liquid Level – Sensor Wet	Verify HEATER (TD1) / HTR (TD2) is set to “-” Change HEATER/HTR to “+” Light goes off—contact factory to discuss application. Light stays on—check resistance to determine if a problem exists with the probe or electronics. Refer to Section “RESISTANCE VALUES”. Probe and/or electronics may need to be replaced.
	Liquid Level – Sensor Dry	Verify HEATER (TD1) / HTR (TD2) is set to “-” Turn off FAULT (TD1) / FLT (TD2) Light goes off—operate in this mode Light stays on—check resistance to determine if a problem exists with the probe or electronics. Refer to Section “RESISTANCE VALUES”. Probe and/or electronics may need to be replaced.
	Liquid Flow – Sensor Dry or No Air Flow	Turn off FAULT (TD1) / FLT (TD2) Light goes off—run HEATER/HTR at “+” and FAULT/FLT “off” or run HEATER/HTR at “-” Light stays on—check resistance to determine if a problem exists with the probe or electronics. Refer to Section “RESISTANCE VALUES”. Probe and/or electronics may need to be replaced.
	Liquid Flow – Sensor Wet No Flow	Switch HEATER/HTR to “-” Light goes off—run HEATER/HTR at “+” and FAULT/FLT “off” or run HEATER/HTR at “-” Light stays on—check resistance to determine if a problem exists with the probe or electronics. Refer to Section “RESISTANCE VALUES”. Probe and/or electronics may need to be replaced.

TROUBLESHOOTING

Symptom	Application	Action*
Switch indicates a fault (red LED will blink)	Liquid Flow – Flow Present	Turn off TEMP COMP (TD1) / TC (TD2) Light goes off—operate in this mode Light stays on—check resistance to determine if a problem exists with the probe or electronics. Refer to Section “RESISTANCE VALUES”. Probe and/or electronics may need to be replaced.
	Air Flow – Flow Present	Switch HEATER/HTR to “-” Light goes off—Operate at lower heater power (with less sensitivity). Turn TEMP COMP/TC off if problem continues (requires re-calibration) or operate at HEATER/HTR “+” and make sure FAULT/FLT switch is “off” Light stays on—Return HEATER/HTR switch to “+” and turn TEMP COMP/TC “off”. If light goes off then recalibrate and operate in this mode. If light stays on check resistance to determine if a problem exists with the probe or electronics. Refer to Section “RESISTANCE VALUES”. Probe and/or electronics may need to be replaced.

* Changing HEATER/HTR, TEMP COMP/TC or media switch position requires recalibration.

RESISTANCE VALUES

The following tables provide the expected resistance values for the sensor. Refer to the indicated figures for pin locations. Refer to section “REPLACEMENT PARTS / Probe replacement” for removing bezel and circuit boards.

TD1

Pin	Expected Resistance
1 to 3	90 to 180 ohms (275 ohms with high temperature probe)
2 to 4	90 to 180 ohms (275 ohms with high temperature probe)

TD2 – Integral Electronics

TD2 – Remote Electronic Enclosure

Pin	Expected Resistance
1 to 3 or 4	90 to 180 ohms (90 to 275 ohms with high temperature probe)
2 to 5 or 6	90 to 180 ohms (90 to 275 ohms with high temperature probe)
1 to 2, 3 to 4, 5 to 6	0 to 12 ohms

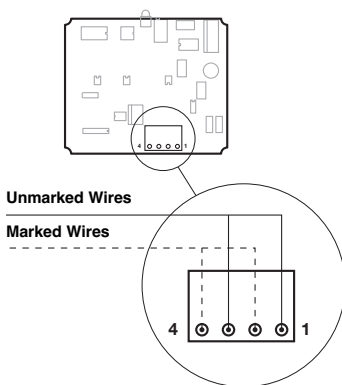

TD1 Probe Connections

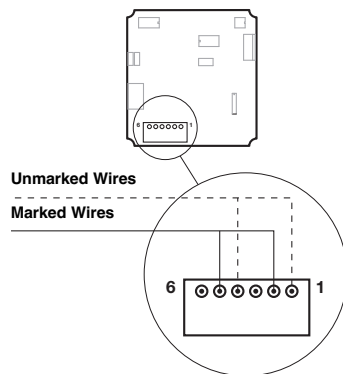

TD2 Integral Probe Connections

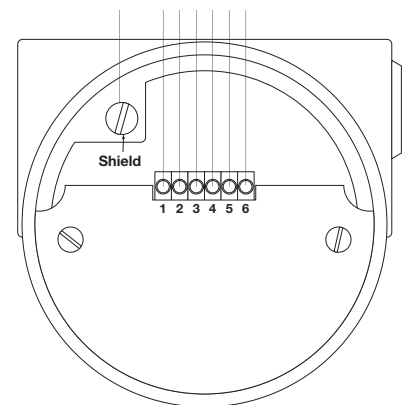

TD2 Remote Probe Connections

MAINTENANCE

Cleaning

The probe may be cleaned by soaking, spraying solvents or detergent and water onto the sensor tubes, or by ultrasonic cleaning. Lime deposits may be safely removed by soaking in 20 % hydrochloric acid. Warming to +65 °C (+150 °F) is permissible to speed this process.

For unusual cleaning problems, contact the factory and determine the exact materials of construction and chemical compatibility before using strong acids or unusual cleansers.

REPLACEMENT PARTS

Note: The switch will require recalibration (see page 5) following probe or electronics replacement.

Probe replacement

INTEGRAL ELECTRONICS

Removal of probe

1. Make sure the power source is turned off.
2. Unscrew and remove housing cover.
3. Remove the bezel by:
 - a. TD1 – removing the fastening screws.
 - b. TD2 – put a screwdriver blade through hole in center and gently pull the handle away from the terminal strips.
4. Remove the fastening screws for the bracket. Remove bracket and attached circuit boards.
5. Loosen the screws on the terminal block to remove the four leads from the probe. Note that the TD1 uses a four position terminal block and the TD2 uses a six position terminal block.
6. Unscrew probe from enclosure.

Installation of replacement probe

1. The probe's leads have been separated at the factory. One set of leads is marked with a "1," the second set is unmarked. Connect leads from RTD #1:
 - TD1 – Connect between terminals 1 and 3.
 - TD2 – Connect between terminals 2 and 5.
2. Connect the second set of leads:
 - TD1 – Connect between terminals 2 and 4.
 - TD2 – Connect between terminals 1 and 4.
3. Replace bezel and housing cover.
 - TD1 – Replace bezel and refasten screws.
 - TD2 – Reinstall bracket assembly. Ensure that the tab at the bottom of the bracket engages in the hole in the bottom of housing. Reinstall bracket mounting screws. Replace bezel by gently pressing down on the center of the bezel. Ensure that the outer edge of bezel is evenly seated in the housing.
4. Replace housing cover.
5. Apply power.
6. Recalibrate as described on page 5.

REMOTE ELECTRONICS (TD2 ONLY)

1. Make sure the power source is turned off.
2. Remove the cover from the sensor enclosure.
3. Loosen the screws on the four position terminal block (TB1) to remove the leads from the probe.
4. Unscrew probe from enclosure.
 - a. The probe's leads have been separated at the factory. Connect leads from RTD #1, which are grouped and marked, to pins 3 & 4 (the two terminals on TB1 closest to the sensor label).
 - b. Connect the other pair of leads, which are not marked, to pins 1 & 2 (the remaining two positions on TB1).
5. Replace housing cover.
6. Apply power.
7. Recalibrate as described on page 5.

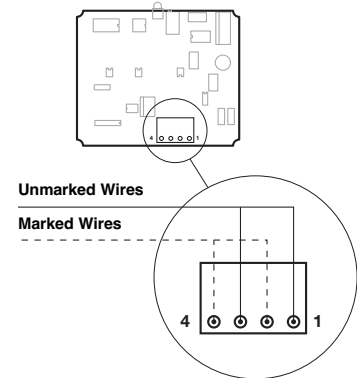

TD1 Probe Connections

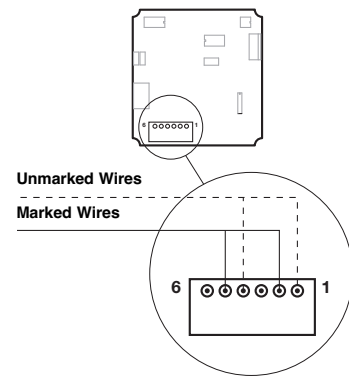

TD2 Integral Probe Connections

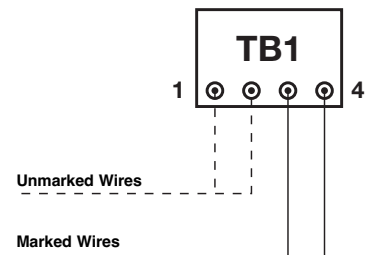

TD2 Remote Probe Connections

REPLACEMENT PARTS

EXPEDITE SHIP PLAN (ESP)

Several parts are available for quick shipment, within max. 1 week after factory receipt of purchase order, through the Expedite Ship Plan (ESP).
Parts covered by ESP service are conveniently grey coded in the selection tables.

Replacement parts – Model TD1

Partn°:

T	D	1							
---	---	---	--	--	--	--	--	--	--

Serial n°:

--	--	--	--	--	--	--	--	--	--

Digit in partn°:

X	1	2	3	4	5	6	7	8	9	10
---	---	---	---	---	---	---	---	---	---	----

See nameplate, always provide complete partn° and serial n° when ordering spares.

↳ X = product with a specific customer requirement

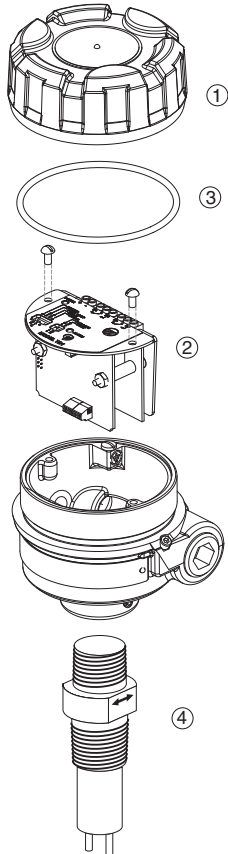

(1) Housing cover	
Digit 10	Replacement part
0 or 1	004-9225-002
2 or 3	004-9225-003

	Replacement part
(2) Electronic module	089-7250-001
(3) "O"-ring	012-2201-237
(4) Sensor	consult factory

REPLACEMENT PARTS

Replacement parts – Model TD2

Partn°:

T D 2 [] [] [] [] [] [] [] [] [] []

Serial n°:

[] []

Digit in partn°:

X 1 2 3 []

See nameplate, always provide complete partn° and serial n° when ordering spares.

X = product with a specific customer requirement

INTEGRAL ELECTRONICS

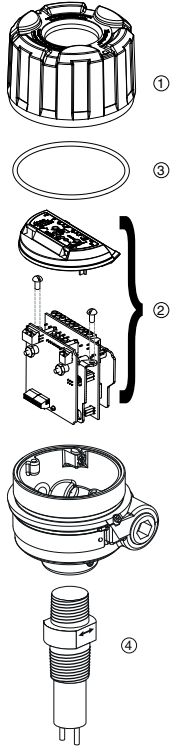

REMOTE ELECTRONICS

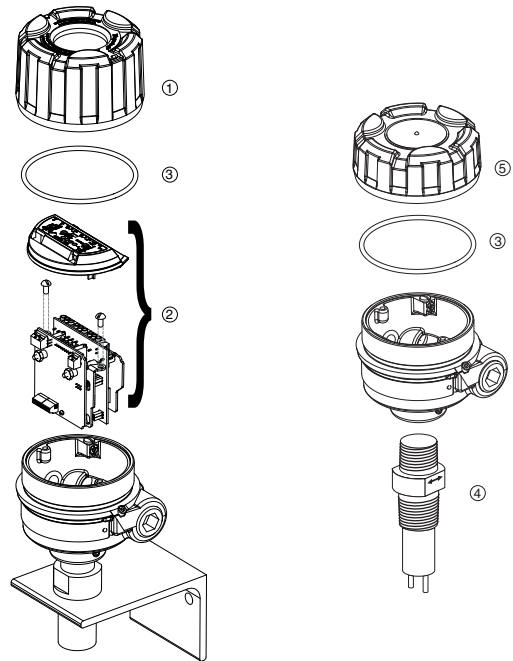

(1) Housing cover		
Digit 7	Digit 10	Replacement part
0	0 or 1	004-9192-009
	2 or 3	004-9224-014
1	0 or 1	036-4410-010
	2 or 3	not applicable

(3) "O"-ring	
Digit 10	Replacement part
0, 1, 2 or 3	012-2201-237

(4) Sensor	
	Replacement part
	consult factory

(5) Housing cover		
Digit 8	Digit 10	Replacement part
1	0 or 1	004-9225-002
	2 or 3	004-9225-003

(2) Electronic module					
Digit 4	Digit 5	Digit 8	Digit 9	Digit 10	Replacement part
7	D	0	3 or G	0, 1, 2 or 3	089-7250-002
			C		089-7250-010
		1	3 or G	0, 1, 2 or 3	089-7250-004
			C		089-7250-012
	H	0	3 or G	0, 1, 2 or 3	089-7250-006
			C		
1		3 or G	0, 1, 2 or 3	089-7250-008	
		C			
8	D	0	3 or G	0, 1, 2 or 3	089-7250-003
			C		089-7250-011
		1	3 or G	0, 1, 2 or 3	089-7250-005
			C		089-7250-013
	H	0	3 or G	0, 1, 2 or 3	089-7250-007
			C		
1		3 or G	0, 1, 2 or 3	089-7250-009	
		C			

MODEL IDENTIFICATION

A complete measuring system consists of:

1. THERMATEL® electronics
2. Connecting cable (only applicable for remote mount TD2 units)
3. THERMATEL® sensor
4. Optional: Order code for thread-on mounting flanges
5. Optional: Retractable probe assembly, consult factory for details
6. Optional: Factory calibration, consult factory



TD1



TD2

1. Code for Thermatel® TD1 electronics

T D 1 - 2 D 0 0 - 0	Integral mount electronics for 24 V DC power supply and with 1 DPDT 8 A DPDT output relay
---------------------	---

APPROVAL

3	Weatherproof
C	ATEX/IEC flameproof enclosure with intrinsically safe probe circuitry

HOUSING / CABLE ENTRY

0	IP66, Cast aluminium, 3/4" NPT cable entry (2 entries - 1 plugged)
1	IP66, Cast aluminium, M20 x 1,5 cable entry (2 entries - 1 plugged)

T D 1 - 2 D 0 0 - 0

complete code for Thermatel® TD1 electronics

→ X = product with a specific customer requirement

MODEL IDENTIFICATION

1. Code for Thermatel® TD2 electronics with housing for industrial use

T	D	2	Electronics with continuous LED indication and mA output		
---	---	---	--	--	--

POWER SUPPLY

7	240 V AC (100-264 V AC)				
8	24 V DC (± 20 %)				

OUTPUT

D	0	8 A DPDT relay			
H	0	1 A Hermetically sealed DPDT relay (Relay contact material: gold plated)			

ACCESSORIES

0	Blind housing cover				
1	Housing cover with glass window (for aluminium housings only)				

MOUNTING CONFIGURATION

0	Integral electronics				
1	Remote electronics				

APPROVAL ^①

3	Weatherproof				
C	Zone 0 – for level applications ATEX/IEC flameproof enclosure with intrinsically safe probe circuitry - no mA output available - only available with 8 A DPDT relay option				
G	Zone 1 – for level and flow applications ATEX/IEC flameproof enclosure				

^① Consult factory for zone 0 applications in combination with hermetically sealed relay.

HOUSING / CABLE ENTRY

0	IP66, Cast aluminium, 3/4" NPT cable entry (2 entries - 1 plugged)				
1	IP66, Cast aluminium, M20 x 1,5 cable entry (2 entries - 1 plugged)				
2	IP66, Cast stainless steel, 3/4" NPT cable entry (2 entries - 1 plugged)				
3	IP66, Cast stainless steel, M20 x 1,5 cable entry (2 entries - 1 plugged)				

T D 2 [] [] [] 0 [] [] [] []

complete code for Thermatel® TD2 electronics with housing for industrial use

X = product with a specific customer requirement

2. Code for connecting cable used with weatherproof remote mount TD2 electronics (6-wire cable/shielded). Consult factory for cable suitable for flameproof enclosure.

0	0	3	-	1	5	0	From 3 m (10 ft) min. to 150 m (500 ft) max. Specify in increments of 1 m (3.28 ft)		
---	---	---	---	---	---	---	---	--	--

0 3 7 [] [] [] 3 1 9 8 [] [] []

complete code for connecting cable

CONNECTIONS

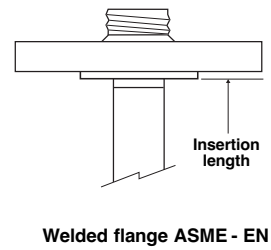
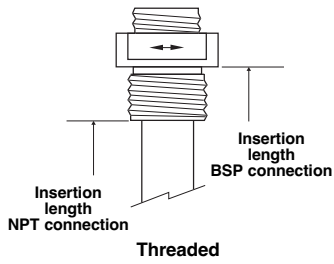

DIMENSIONS IN mm (inches) – TMA/TMB/TMC/TMD

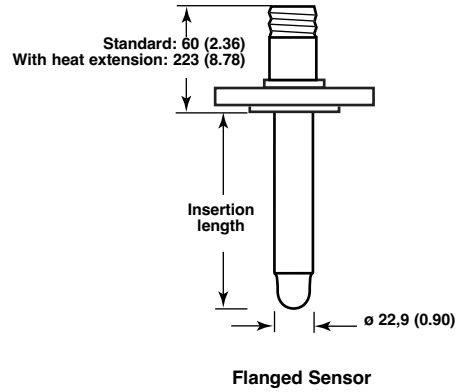
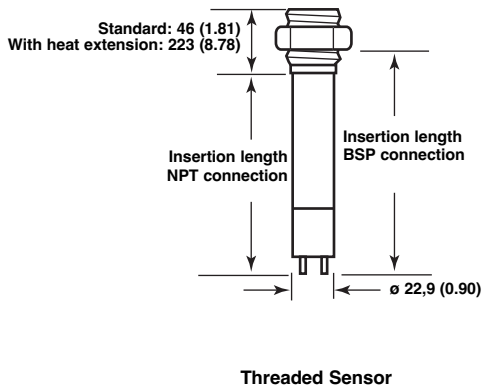

PRESSURE/TEMPERATURE RATING – TMA/TMB/TMC/TMD

Sensor	Material code	Insertion length	Maximum process pressure		
			@ +40 °C (+100 °F)	@ +120 °C (+250 °F)	@ +200 °C (+400 °F)
TMA, TMB	A	All	41,4 bar (600 psi)	33,8 bar (490 psi)	28,6 bar (415 psi)
	K, M, N	All	27,6 bar (400 psi)	22,4 bar (325 psi)	19,0 bar (275 psi)
TMC, TMD	A, D, K, M, N	= minimum length	207 bar (3000 psi)	170 bar (2460 psi)	148 bar (2140 psi)
		> minimum length	128 bar (1850 psi)	105 bar (1517 psi)	91,0 bar (1320 psi)
TMC, TMD	B, F	= minimum length	207 bar (3000 psi)	181 bar (2627 psi)	161 bar (2340 psi)
		> minimum length	103 bar (1500 psi)	90,6 bar (1313 psi)	80,7 bar (1170 psi)
TMC, TMD	C, G	= minimum length	172 bar (2500 psi)	147 bar (2125 psi)	137 bar (1980 psi)
		> minimum length	82,8 bar (1200 psi)	70,3 bar (1020 psi)	65,5 bar (950 psi)

TMA/TMB sensors

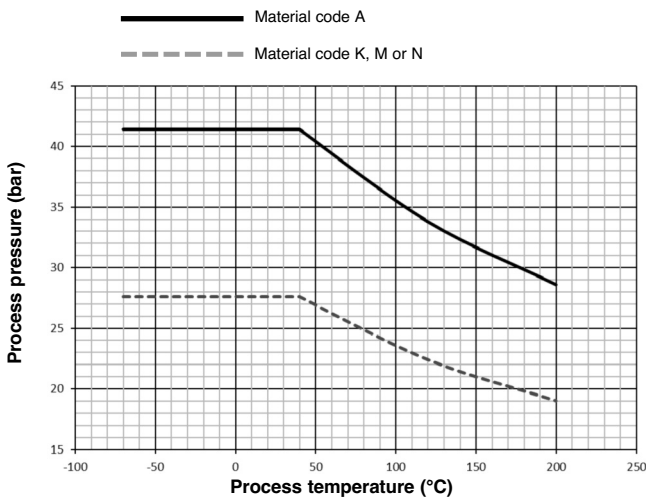

TMC/TMD sensors with material code A, D, K, M or N

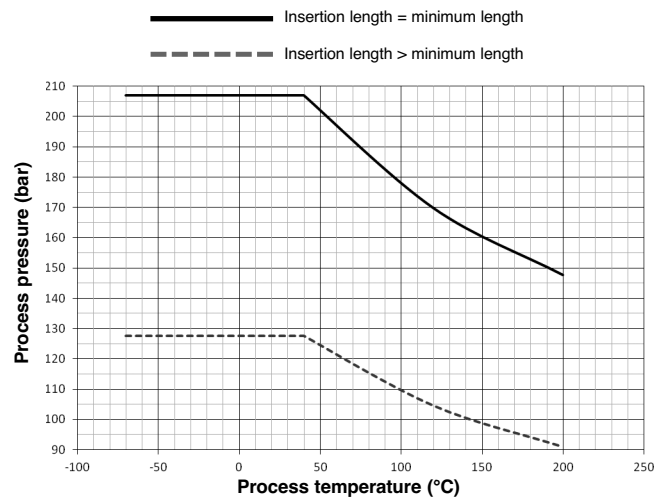

MODEL IDENTIFICATION

3. Order code for Thermatel® TD1/TD2 – STANDARD SENSOR

T M A	Spherical tip - standard	max +120 °C (+250 °F) ^①
T M B	Spherical tip - with heat extension	max +200 °C (+400 °F)
T M C	Twin tip - standard	max +120 °C (+250 °F) ^①
T M D	Twin tip - with heat extension	max +200 °C (+400 °F)

① TMA/TMC sensors can handle process temperatures up to +200 °C (+400 °F) with remote electronics.

MATERIAL OF CONSTRUCTION FOR SENSOR AND PROCESS CONNECTION

A	316/316L (1.4401/1.4404) stainless steel ^①
B	Hastelloy® C (2.4819) – TMC/TMD only
C	Monel® (2.4360) – TMC/TMD only
D	316/316L (1.4401/1.4404) stainless steel – TMC/TMD only
F	Hastelloy® C (2.4819), NACE
G	Monel® (2.4360), NACE
K	316/316L (1.4401/1.4404) stainless steel, ASME B31.3
M	316/316L (1.4401/1.4404) stainless steel, ASME B31.3 and NACE
N	316/316L (1.4401/1.4404) stainless steel, NACE

① Not suitable for zone 0 applications in combination with hermetically sealed relay; use in this case material code D.

PROCESS CONNECTION – SIZE/TYPE

Threaded

1	1	0	3/4" NPT
2	1	0	1" NPT
2	2	0	1" BSP (G 1")

No threads – only for use with compression fitting

0	0	0	Compression fitting (customer-supplied)
---	---	---	---

ASME flanges

2	3	0	1"	150 lbs ASME RF
2	4	0	1"	300 lbs ASME RF
2	5	0	1"	600 lbs ASME RF
3	3	0	1 1/2"	150 lbs ASME RF
3	4	0	1 1/2"	300 lbs ASME RF

3	5	0	1 1/2"	600 lbs ASME RF
4	3	0	2"	150 lbs ASME RF
4	4	0	2"	300 lbs ASME RF
4	5	0	2"	600 lbs ASME RF

EN flanges

B	B	0	DN 25	PN 16/25/40	EN 1092-1	Type A
B	C	0	DN 25	PN 63/100	EN 1092-1	Type B2
C	B	0	DN 40	PN 16/25/40	EN 1092-1	Type A
C	C	0	DN 40	PN 63/100	EN 1092-1	Type B2
D	A	0	DN 50	PN 16	EN 1092-1	Type A
D	B	0	DN 50	PN 25/40	EN 1092-1	Type A
D	D	0	DN 50	PN 63	EN 1092-1	Type B2
D	E	0	DN 50	PN 100	EN 1092-1	Type B2

INSERTION LENGTH – MINIMUM

		Sensor	Process connection		
0	0	5	5 cm (2")	TMA, TMB	NPT
0	0	6	5,5 cm (2.17")		flanged
0	0	7	7 cm (2.76")		BSP
0	0	6	5,5 cm (2.17")	TMC, TMD	NPT, flanged
0	0	8	7,5 cm (3")		BSP

INSERTION LENGTH – SELECTABLE – Specify per cm (0.39") increment

		Sensor	Process connection		
0	0	6	Minimum 6 cm (2.36")	TMA, TMB	NPT
0	0	7	Minimum 7 cm (2.76")		flanged
0	0	8	Minimum 8 cm (3.15")		BSP
0	0	7	Minimum 7 cm (2.76")	TMC, TMD	NPT, flanged
0	0	9	Minimum 9 cm (3.54")		BSP
3	3	0	Maximum 330 cm (130")	all	all

T M [] [] [] [] 0 [] [] [] []

complete order code for Thermatel® TD1/TD2 STANDARD SENSOR

X = product with a specific customer requirement

DIMENSIONS IN mm (inches) – TMH



PRESSURE/TEMPERATURE RATING – TMH

Maximum process pressure			
@ +40 °C (+100 °F)	@ +120 °C (+250 °F)	@ +200 °C (+400 °F)	@ +450 °C (+850 °F)
414 bar (6000 psi)	339 bar (4920 psi)	295 bar (4280 psi)	233 bar (3380 psi)

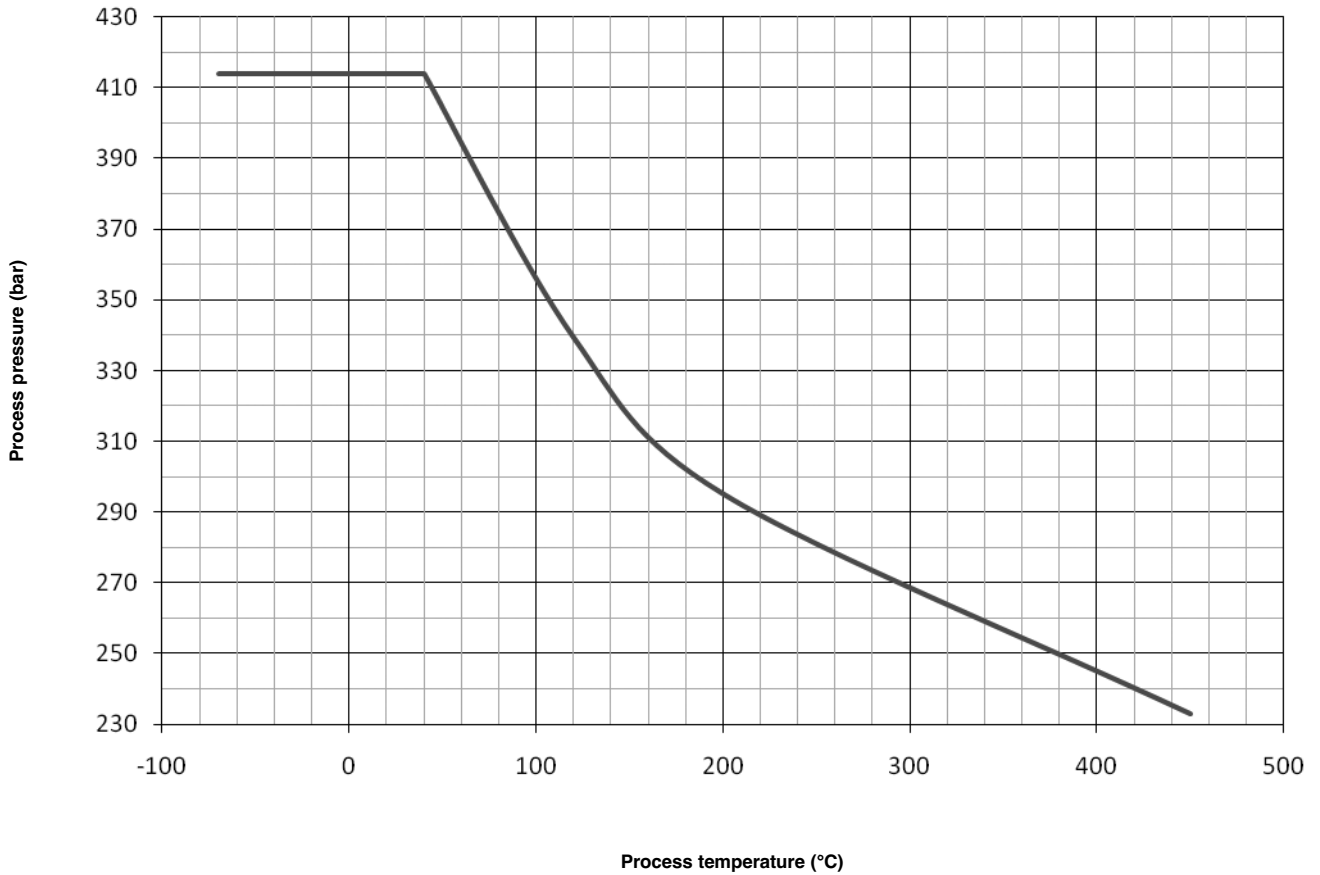

MODEL IDENTIFICATION

3. Order code for Thermatel® TD1/TD2 – HIGH TEMPERATURE / HIGH PRESSURE SENSOR

T M H	High temperature / high pressure twin tip – max +450 °C (+850 °F) / max 414 bar (6000 psi) ^①
-------	---

^① Not available with retractable probe assembly.

MATERIAL OF CONSTRUCTION FOR SENSOR AND PROCESS CONNECTION

A	316/316L (1.4401/1.4404) stainless steel ^①
B	Hastelloy® C (2.4819)
D	316/316L (1.4401/1.4404) stainless steel
F	Hastelloy® C (2.4819), NACE
K	316/316L (1.4401/1.4404) stainless steel, ASME B31.3 (CRN Available)
M	316/316L (1.4401/1.4404) stainless steel, ASME B31.3 and NACE (CRN Available)
N	316/316L (1.4401/1.4404) stainless steel, NACE

^① Not suitable for zone 0 applications in combination with hermetically sealed relay; use in this case material code D.

PROCESS CONNECTION – SIZE/TYPE

Threaded

1 1 0	3/4" NPT
2 1 0	1" NPT
2 2 0	1" BSP (G 1")

ASME flanges

2 3 0	1"	150 lbs	ASME RF	3 7 0	1 1/2"	900/1500 lbs	ASME RF
2 4 0	1"	300 lbs	ASME RF	3 8 0	1 1/2"	2500 lbs	ASME RF
2 5 0	1"	600 lbs	ASME RF	4 3 0	2"	150 lbs	ASME RF
2 7 0	1"	900/1500 lbs	ASME RF	4 4 0	2"	300 lbs	ASME RF
3 3 0	1 1/2"	150 lbs	ASME RF	4 5 0	2"	600 lbs	ASME RF
3 4 0	1 1/2"	300 lbs	ASME RF	4 7 0	2"	900/1500 lbs	ASME RF
3 5 0	1 1/2"	600 lbs	ASME RF	4 8 0	2"	2500 lbs	ASME RF

EN flanges

B B 0	DN 25	PN 16/25/40	EN 1092-1 Type A
B C 0	DN 25	PN 63/100	EN 1092-1 Type B2
B G 0	DN 25	PN 250	EN 1092-1 Type B2
C B 0	DN 40	PN 16/25/40	EN 1092-1 Type A
C C 0	DN 40	PN 63/100	EN 1092-1 Type B2
C G 0	DN 40	PN 250	EN 1092-1 Type B2
C J 0	DN 40	PN 400	EN 1092-1 Type B2
D A 0	DN 50	PN 16	EN 1092-1 Type A
D B 0	DN 50	PN 25/40	EN 1092-1 Type A
D D 0	DN 50	PN 63	EN 1092-1 Type B2
D E 0	DN 50	PN 100	EN 1092-1 Type B2
D G 0	DN 50	PN 250	EN 1092-1 Type B2
D J 0	DN 50	PN 400	EN 1092-1 Type B2

INSERTION LENGTH – MINIMUM

		Process connection
0 0 6	5,5 cm (2.17")	NPT
0 0 7	7 cm (2.76")	flanged
0 0 8	7,5 cm (3")	BSP

INSERTION LENGTH – SELECTABLE – Specify per cm (0.39") increment

		Process connection
0 0 7	Minimum 7 cm (2.76")	NPT
0 0 8	Minimum 8 cm (3.15")	flanged
0 0 9	Minimum 9 cm (3.54")	BSP
0 9 1	Maximum 91 cm (36")	all



**complete order code for Thermatel® TD1/TD2
HIGH TEMPERATURE /HIGH PRESSURE SENSOR**

→ X = product with a specific customer requirement

MODEL IDENTIFICATION

3. Order code for Thermanel® TD1/TD2 – MINI SENSOR

T M M	Mini twin tip – max +120 °C (+250 °F) ^①
-------	--

^① TMM sensors can handle process temperatures up to +200 °C (+400 °F) with remote electronics.

MATERIAL OF CONSTRUCTION FOR SENSOR AND PROCESS CONNECTION

A	316/316L (1.4401/1.4404) stainless steel (CRN Available) ^①
N	316/316L (1.4401/1.4404) stainless steel, NACE (CRN Available)

^① Not suitable for zone 0 applications in combination with hermetically sealed relay.

PROCESS CONNECTION – SIZE/TYPE Threaded

0 1 0	1/2" NPT
1 1 0	3/4" NPT
2 1 0	1" NPT

INSERTION LENGTH – MINIMUM

0 0 3	2,5 cm (1")
-------	-------------

INSERTION LENGTH – SELECTABLE – Specify per cm (0.39") increment

0 0 5	Minimum 5 cm (2")
3 3 0	Maximum 330 cm (130")



complete order code for Thermanel® TD1/TD2 MINI SENSOR

X = product with a specific customer requirement

DIMENSIONS IN mm (inches) & PRESSURE/TEMPERATURE RATING – TMM

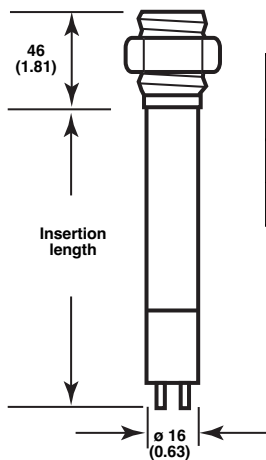

Insertion length	Maximum process pressure		
	@ +40 °C (+100 °F)	@ +120 °C (+250 °F)	@ +200 °C (+400 °F)
= 2,5 cm (1")	207 bar (3000 psi)	170 bar (2460 psi)	148 bar (2140 psi)
> 2,5 cm (1")	128 bar (1850 psi)	105 bar (1517 psi)	91,0 bar (1320 psi)

— Insertion length = minimum length
 - - - - - Insertion length > minimum length

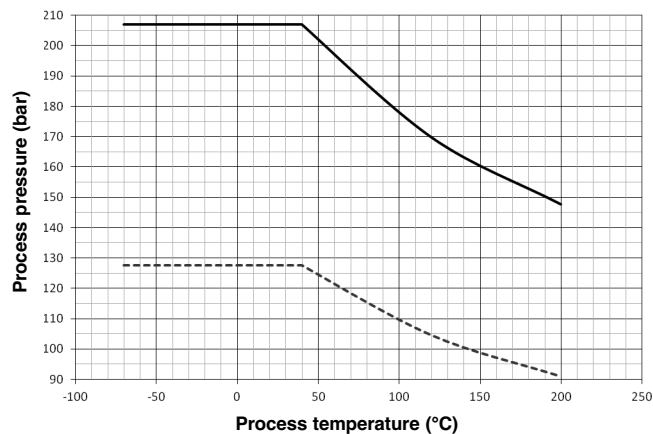

RECOMMENDED FLOW RANGES – TMM

Pipe size	Water	Air
1/2"	0,75 to 680 l/h (0.2 to 180 GPH)	0,85 to 120 Nm ³ /h (0.5 to 70 SCFM)
3/4"	2 to 900 l/h (0.5 to 240 GPH)	2,5 to 170 Nm ³ /h (1.5 to 100 SCFM)
1"	3,8 to 1600 l/h (1 to 420 GPH)	5 to 290 Nm ³ /h (3 to 170 SCFM)

MODEL IDENTIFICATION

3. Order code for Thermatel® TD1/TD2 – LOW FLOW BODY SENSOR

T M L	Low flow body – max +120 °C (+250 °F) ^① / max 400 bar (5800 psi)
-------	---

^① TML sensors can handle process temperatures up to +200 °C (+400 °F) with remote electronics.

MATERIAL OF CONSTRUCTION FOR SENSOR AND PROCESS CONNECTION

A	316/316L (1.4401/1.4404) stainless steel ^①
---	---

^① Not suitable for zone 0 applications in combination with hermetically sealed relay.

PROCESS CONNECTION – SIZE/TYPE

Threaded

T 1	1/4" NPT-F (CRN Available)
V 1	1/2" NPT-F (CRN Available)
T 0	1/4" BSP (G 1/4")
V 0	1/2" BSP (G 1/2")

SENSITIVITY

0	Standard
1	High Sensitivity ^①

^① Only available for gas applications and when digit 5 = T.

MOUNTING BRACKET

0 0 0	None
1 0 0	With carbon steel mounting bracket

complete order code for Thermatel® TD1/TD2 LOW FLOW BODY SENSOR

X = product with a specific customer requirement

DIMENSIONS IN mm (inches) & PRESSURE/TEMPERATURE RATING – TML

Sensitivity (refer to digit 7)	Maximum process pressure		
	@ +40 °C (+100 °F)	@ +120 °C (+250 °F)	@ +200 °C (+400 °F)
Standard sensitivity	517 bar (7500 psi)	517 bar (7500 psi)	500 bar (7250 psi)
High sensitivity	400 bar (5800psi)	328 bar (4760 psi)	283 bar (4100 psi)

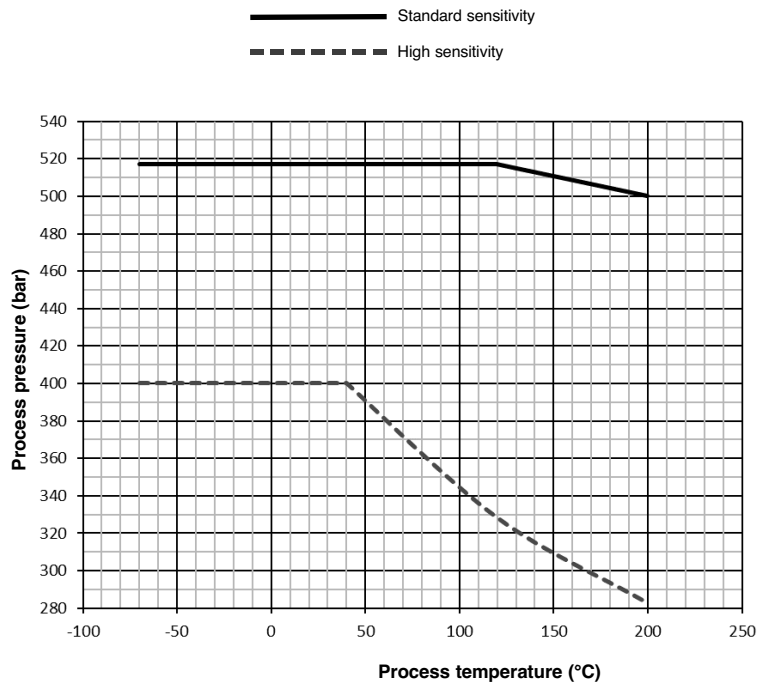
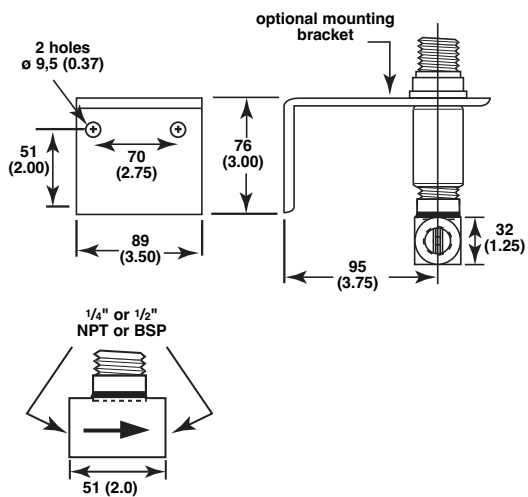

RECOMMENDED FLOW RANGES – TML

Size	Water	Air
1/4" flow body	0,02 to 5,7 l/h (0.0055 to 1.5 GPH)	0,071 to 5,75 Nm ³ /h (2.5 to 200 SCFH) ^①
1/2" flow body	0,04 to 11,5 l/h (0.01 to 3 GPH)	0,071 to 11,5 Nm ³ /h (2.5 to 400 SCFH)

^① For 0,0078 to 0,0708 Nm³/h (0.064 to 2.5 SCFH) use high sensitivity low flow body sensor.

MODEL IDENTIFICATION

4. Optional sensor mounting flanges

Thread-on mounting flanges can only be used in combination with 3/4" NPT process connection sensor. Consult factory for other sizes or materials.

Thread-on flanges for use with 3/4" NPT-M connections

ASME B16.5 flanges		Part No.		
		Carbon steel	316/316L SST	Hastelloy C
1"	150 lbs RF	004-5867-041	004-5867-043	004-5867-052
1 1/2"	150 lbs RF	004-5867-021	004-5867-001	004-5867-031
2"	150 lbs RF	004-5867-022	004-5867-002	004-5867-032
3"	150 lbs RF	004-5867-023	004-5867-003	004-5867-033
4"	150 lbs RF	004-5867-024	004-5867-004	004-5867-034
6"	150 lbs RF	004-5867-025	004-5867-005	004-5867-035
1"	300 lbs RF	004-5867-042	004-5867-044	004-5867-053
1 1/2"	300 lbs RF	004-5867-026	004-5867-006	004-5867-036
2"	300 lbs RF	004-5867-027	004-5867-007	004-5867-037
3"	300 lbs RF	004-5867-028	004-5867-008	004-5867-038
4"	300 lbs RF	004-5867-029	004-5867-009	004-5867-039
6"	300 lbs RF	004-5867-030	004-5867-010	004-5867-040
1"	600 lbs RF	004-5867-051	004-5867-050	004-5867-054
1 1/2"	600 lbs RF	004-5867-046	004-5867-045	004-5867-055
2"	600 lbs RF	004-5867-049	004-5867-048	004-5867-056

DIMENSIONS IN mm (inches) – WITH HOUSING FOR INDUSTRIAL USE

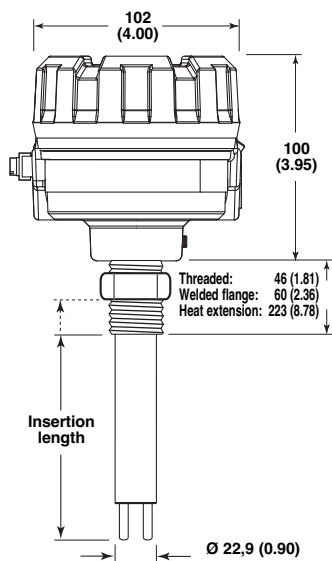

Model TD1 with TMC/TMD twin tip sensor

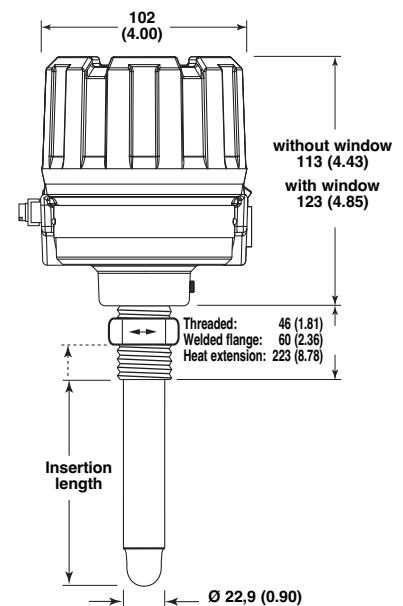

Model TD2 with integral electronics and TMA/TMB spherical tip sensor

DIMENSIONS IN mm (inches) – WITH HOUSING FOR INDUSTRIAL USE

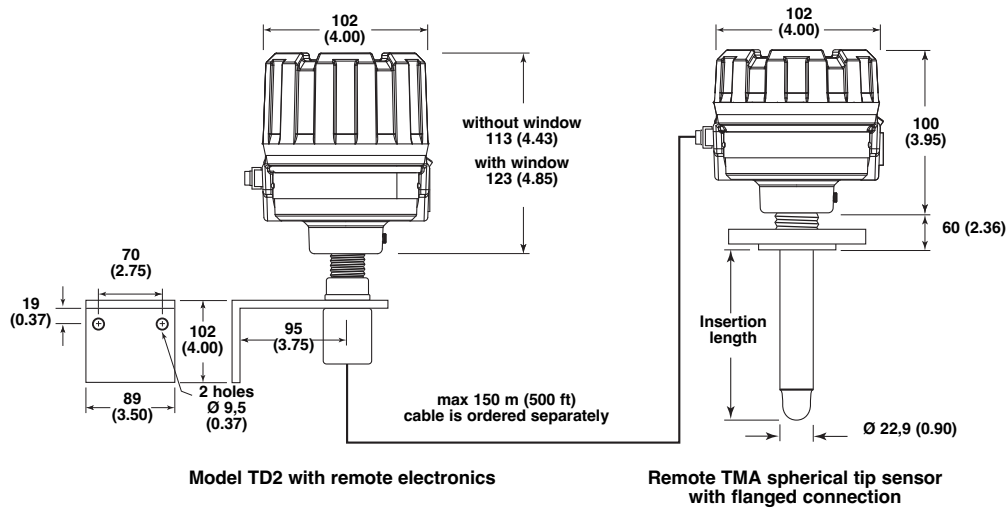

Model TD2 with remote electronics

Remote TMA spherical tip sensor with flanged connection

SPECIFICATIONS

Electronics specifications – with housing for industrial use

Description		TD1	TD2
Power supply		19,2 to 28,8 V DC	19,2 to 28,8 V DC 100 to 264 V AC, 50-60 Hz
Power consumption		3,5 W @ 24 V DC	4 W @ 24 V DC or 5 W @ 264 V AC
Flow range	Water	0,01 to 5,0 FPS (0,003 to 1,5 m/s)(spherical tip and twin tip sensors) 0,01 to 1,0 FPS (0,003 to 0,3 m/s)(HTHP, Hastelloy, Monel sensors)	
	Air	0,01 to 500 SFPS (0,03 to 150 Nm/s)	
Output	Alarm	DPDT relay: 8 A @ 120 V AC / 250 V AC 8 A @ 30 V DC; 0,5 A @ 125 V DC	
		Hermetically sealed relay not available	Hermetically sealed DPDT relay: 1A @ 28 V DC; 0,2 A @ 125 V DC
	Continuous	Not applicable	
	Error	Via alarm relay	3,6 mA (Low Level Fail-safe) – 22 mA (High Level Fail-safe) and alarm relay
Time delay		Not available	0 to 100 s adjustable (in addition to sensor response time)
User interface		- Local switches for gain setting, function setting and High/Low Level Fail-safe - Calibration and time delay via potentiometer	
Display		LED's for Power/Alarm status	2 green LED's (safe condition), 1 yellow LED (alarm setpoint being approached) 1 red LED (alarm condition)
Approvals		ATEX II 2 G Ex d IIC T5..T4 Gb, flameproof enclosure - TD2 for zone 1 ATEX II 1/2 G Ex d+ib, d [ib] IIC T5..T4 Ga/Gb, flameproof enclosure - TD1 & TD2 (TD2 only with 8A DPDT relay) IEC Ex d + ib, d [ib] IIC T5/T4 Gb/Ga - TD1 & TD2 IEC Ex d IIC T5/T4 Gb - TD2 only Other approvals are available, consult factory for more details	
SIL (Safety Integrity Level)		Functional safety to SIL1 as 1oo1 / SIL2 as 1oo2 in accordance to IEC 61508 – SFF of 69,3 % (TD1) and 73 % (TD2) – full FMEDA reports and declaration sheets available	
Housing material		IP66/Aluminium A356T6 (<0.20 % copper) or stainless steel	
Net weight		Aluminium: 1,1 kg (2.4 lbs) - integral electronics only Stainless steel: 2,6 kg (5.7 lbs) - integral electronics only	

SPECIFICATIONS

Performance

Description	Specification
Response time	1-10 s typical (dependent on sensor type, application and set point)
Repeatability	< 1 % @ constant temperature
Ambient temperature	ATEX/IEC Ex d - T4 & non Ex: -40 °C to +70 °C (-40 °F to +160 °F) ATEX/IEC Ex d - T5: -40 °C to +40 °C (-40 °F to +104 °F) Storage: -50 °C to +75 °C (-58 °F to +170 °F)
Humidity	0-99 %, non-condensing
Electromagnetic compatibility	Meets CE requirements (EN 61326: 1997 + A1 + A2)

Sensor specifications

Description	Spherical tip - Twin tip sensors INDUSTRIAL TMA/TMB - TMC/TMD	HTHP sensor TMH
Materials	316/316L (1.4401/1.4404) Hastelloy® C (2.4819) – TMC/TMD only Monel® (2.4360) – TMC/TMD only	316/316L (1.4401/1.4404) Hastelloy® C (2.4819)
Sensor diameter	22,9 mm (0.90")	21,9 mm (0.86")
Process connection	Threaded: NPT or BSP Flanged: various ASME or EN flanges	
Sensor length	5 - 330 cm (2" - 130")	5,5 - 91 cm (2.17" - 36")
Process temperature	TMA/TMC ^① : -70 °C to +120 °C (-100 °F to +250 °F) TMB/TMD: -70 °C to +200 °C (-100 °F to +400 °F)	-70 °C to +450 °C (-100 °F to +850 °F)
Max process pressure	See info on page 13	See info on page 15

^① Use remote electronics (TD2) for temperatures > +120 °C (+250 °F) up to max +200 °C (+400 °F) or sensors with heat extension (TMB/TMD) when using integral electronics.

Description	Mini twin tip sensor TMM	Low flow body TML
Materials	316/316L (1.4401/1.4404)	
Sensor diameter	16 mm (0.63")	1/4" or 1/2" pipe size
Process connection	Threaded: 1/2", 3/4" or 1" NPT	Threaded: 1/4" or 1/2" NPT-F or BSP
Sensor length	2,5 - 330 cm (1" - 130")	Not applicable
Process temperature	-70 °C to +120 °C (-100 °F to +250 °F) ^①	
Max process pressure	See info on page 17	See info on page 18

^① Use remote electronics (TD2) for temperatures > +120 °C (+250 °F) up to max +200 °C (+400 °F).

IMPORTANT

SERVICE POLICY

Owners of Magnetrol products may request the return of a control; or, any part of a control for complete rebuilding or replacement. They will be rebuilt or replaced promptly. Magnetrol International will repair or replace the control, at no cost to the purchaser, (or owner) **other than transportation cost** if:

- a. Returned within the warranty period; and,
- b. The factory inspection finds the cause of the malfunction to be defective material or workmanship.

If the trouble is the result of conditions beyond our control; or, is **NOT** covered by the warranty, there will be charges for labour and the parts required to rebuild or replace the equipment.

In some cases, it may be expedient to ship replacement parts; or, in extreme cases a complete new control, to replace the original equipment before it is returned. If this is desired, notify the factory of both the model and serial numbers of the control to be replaced. In such cases, credit for the materials returned, will be determined on the basis of the applicability of our warranty.

No claims for misapplication, labour, direct or consequential damage will be allowed.

RETURNED MATERIAL PROCEDURE

So that we may efficiently process any materials that are returned, it is essential that a "Return Material Authorisation" (RMA) form will be obtained from the factory. It is mandatory that this form will be attached to each material returned. This form is available through Magnetrol's local representative or by contacting the factory. Please supply the following information:

1. Purchaser Name
2. Description of Material
3. Serial Number and Ref Number
4. Desired Action
5. Reason for Return
6. Process details

Any unit that was used in a process must be properly cleaned in accordance with the proper health and safety standards applicable by the owner, before it is returned to the factory.

A material Safety Data Sheet (MSDS) must be attached at the outside of the transport crate or box.

All shipments returned to the factory must be by prepaid transportation. Magnetrol **will not accept** collect shipments.

All replacements will be shipped Ex Works.

UNDER RESERVE OF MODIFICATIONS

BULLETIN N°: BE 54-610.9
EFFECTIVE: JULY 2019
SUPERSEDES: August 2017

European Headquarters & Manufacturing Facility

Heikensstraat 6

9240 Zele, Belgium

Tel: +32-(0)52-45.11.11 • Fax: +32-(0)52-45.09.93

e-mail: info@magnetrol.be

www.magnetrol.com

