

SM6100 VIBRATION INPUT MONITOR

Installation Manual



The SM6100 is a versatile protection instrument capable of measuring excessive vibration. In its standard configuration, the SM6100 is an economical single input vibration monitor loaded with standard features and packaged in an industrial grade housing. Fully configured, the SM6100 provides for machine control with optional LCD readout, real time remote operator interface via 4-20 mA and an external BNC (weather-proof only) for easy analyst access to the buffered dynamic vibration signal.



SPECIFICATIONS

Sensor	External accelerometer, velometer or velocity transducer. See option 'G' in SM6100 Datasheet (doc # 1009514).
Signal Conditioner	Amplifier/ integrator to obtain velocity or displacement response. True RMS detection.
Maximum Vibration Limit	50 g, peak; 4 ips, peak. See option "B" for vibration ranges in SM6100 Datasheet (doc # 1009514).
Buffered Dynamic Signal	(Vxducer) (gain X1) 2 Hz to 3000 Hz (-3 dB). Capable of driving 300 meters (1000 feet) of shielded cable (0.03uF max).
Sensor OK Indicator	A green LED when illuminated indicates that the external sensor is connected.
Alarm Limit(s)	Single limit standard, second limit optional, Adjustable from -10% to 110% of range, 2% repeatability.
Trip Indicators	Limit 1, amber LED; Limit 2, red LED
Limit Trip Delay	Fully adjustable time delay of 1 - 15 seconds

SPECIFICATIONS (continued)

Triac Outputs	250 VAC, 1A, optically isolated, field selectable N.O. or N.C. Factory set @ N.C. position. Holding current 35 mA maximum at 25°C (60 mA at -40°C).
Optional FET Output	50 VDC, 0.5A, Field Selectable N.O. or N.C. Factory set @ N.C.
Startup Trip Delay	Standard delay is fixed at 30 seconds. Optional remotely retriggerable startup delay adjustable from 1 - 30 seconds.
Optional 4-20 mA Source Output	4-20 mA proportional to velocity or displacement. See option "B" in SM6100 Datasheet (doc # 1009514). Zero and Span calibrated $\pm 2\%$. Non-linearity less than 2%. 600 ohms max. load resistance.
Weight	2 Kg, (4.4 lbs).
Housing	Cast aluminum: Explosion-proof / weather proof. Stud mount: 1/2-14 NPT standard or optional M20 X 1.5 straight thread with jam nut. Other mountings available.
Conduit connections	3/4-14 NPT or M20 X 1.5 straight thread.
Input power	95 to 125 VAC, 190 to 250 VAC, 50/60 Hz, 5W max. or 20 to 28 VDC, 7W max. Power isolated from circuits.
Frequency Response	(vel) ± 3.0 dB 2 Hz to 3000 Hz (disp) ± 3.0 dB 2 Hz to 200 Hz
Temperature Limits	No Display: -40°C to +85°C, -20°C to +85°C (ATEX) w/Display: -10°C to +70°C
Output Sensitivity vs Temperature	Less than .05%/°C (calibrated at 25°C)
Alarm Test	Alarm limit adjustment to below 0% of range causes triac/ FET actuation.
Field Wiring	Wire clamp type screw terminal block. Max. wire gauge: 14 AWG. 500 Vrms, circuit to case.
Hazard Rating	See option "D" in SM6100 Datasheet (doc # 1009514)
Environmental Rating	NEMA 4/4X, IP 65
Electromagnetic Compatibility	CE tested to EN61326-1:2006.
Optional Display	2 1/2 digit LCD. Window provided only with display version.
Reset	Standard internal switch, remote N.O. contacts or optional external switch.

OUTLINE & DIMENSIONS

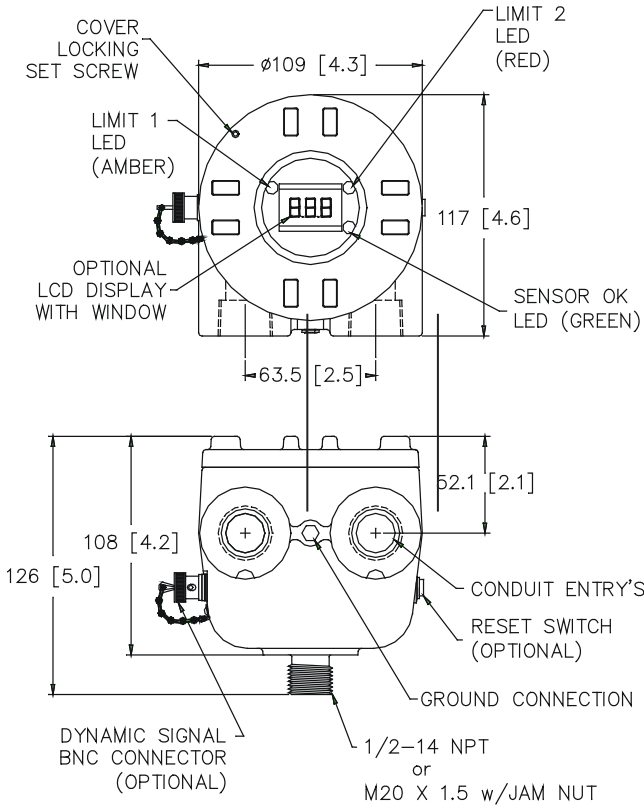

Aprox. Weight:
272 g (0.6 lbs)

Units:
mm [in.]

MECHANICAL INSTALLATION

Monitor Installation

The Model SM6100 Monitor can be mounted in any convenient location where the display can be viewed. Unit requires a tapped hole, see Option F in SM6100 Datasheet (doc # 1009514) or use a Metrix model 7084 flange mount adapter.

If an NPT mounting stud is selected, the stud will tighten before the switch casing touches the machine case. The SM6100 should be hand tightened and then wrench tightened to bring the conduit connections to the appropriate location. Studs with straight threads are provided with a locking nut.

Baseefa Special Conditions for Safe Use:

Ambient Operating Temperature: -40°C to +85°C (model without display), -10°C to +70°C (model with display)

WIRING

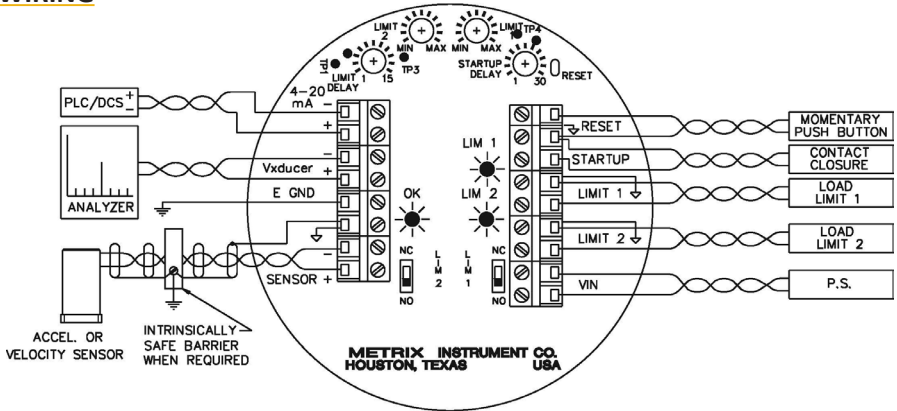

Figure 1: Wiring Diagram (LCD option not shown)

NOTE:

- 1) Diagrams show all available options, see SM6100 Datasheet (doc # 1009514) to verify options on your particular unit.
- 2) On Single Limit Models, use Load Limit Two (2) connection.

NOTE: On ATEX approved units, a locking set screw must be loosened prior to lid removal.

Terminal Wiring

If you have selected the optional display, the display circuit board must be removed (two screws) to expose the terminal strips. The display board cable should not be disconnected. Place the display board out of the way to allow wiring to the terminal strips. The display may be reinstalled in any of the four possible orientations.

Refer to figure 1 for wiring information. For incoming power and switch output(s) use approved wire of 14 AWG (1.5 sq. mm) or smaller.

Note: On ATEX installations, a means for disconnecting power to the switch must be provided. Also, the symbol signifies a protective earth terminal. For reset and startup delay functions, use a twisted pair to reduce electrical noise pickup.

For the current and dynamic signal outputs a shielded, twisted pair is recommended. By convention, the shield should be tied to common only at the receiver end. A cable consisting of separate shielded twisted pairs can also be used. For the dynamic signal output the capacitance of the cable run must not exceed .03 uF (typically 1000 feet).

CAUTION: Conduit seals are highly recommended to prevent the entry of moisture into the switch. Moisture will damage the switch and void the warranty.

Power Wiring

It is highly recommended that all power and triac/FET wiring be routed separately from the external sensor, the dynamic signal and 4-20mA wiring in order to reduce AC/transient noise pickup. The power required is indicated on the nameplate. The voltage supply must be within the following limits:

24 VDC: 20 to 28 VDC

115 VAC: 95 to 125 VAC, 50/60 Hz

230VAC: 190 to 250 VAC, 50/60 Hz

Polarity does not need to be observed when wiring for DC power. The preferred method of operation is to continuously apply power to the SM6100. If power is to be applied as a part of the machine startup sequence it is advisable to apply power to the SM6100 30 seconds prior to starting the machine in order to allow the electronics circuits to stabilize. This is particularly important if the adjustable startup delay option is utilized and the delay is set to less than 20 seconds.

Alarm Limit Triac Output Wiring

The triac output(s) are electro-optically isolated from each other, power, and the internal circuit. These are medium power devices with high immunity to electrical transients. If desired, each triac can be supplied from an AC voltage source different from the main supply. The triacs can be connected in series with the triacs of other units. See Fig. 2. Parallel connection of two switches doubles the triac holding (minimum load) current requirements. The maximum triac supply voltage is 250 VAC. The worst case triac leakage (off) current is 2 mA. The maximum triac holding current is 35 mA at 25°C (60mA at -40°C) which requires that the relay pull-in current have a greater value. Do not use a DC supply. The triacs can be set for NC or NO operation by positioning the Limit 1/Limit 2 switches accordingly.

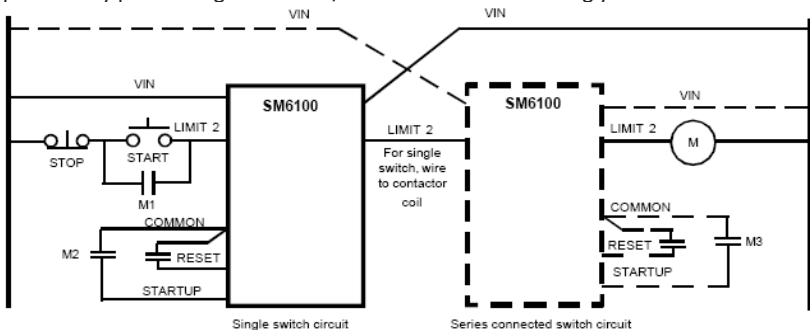

FIGURE 2: Parallel connection of two SM6100

A. Set each SM6100 for N.C. (normally closed) operation. (See Fig. 1)

B. M2, M3 and remote reset contacts must be isolated

Alarm Limit FET Output Wiring (optional)

The optional FET limit output(s) provide a low leakage switch for DC inputs to PLC's or other devices. Do not use on an AC supply. Observe proper polarity when wiring the FET(s) (See figure 1). Damage to the FET(s) will result from improper wiring. As with the triacs, the FET(s) can be set for N.C. or N.O. operation by positioning the Limit 1/Limit 2 switches accordingly.

Limit Trip Delay

The base unit has an adjustable (1-15 sec.) limit trip delay. The vibration level must be continuously above the limit setting for the duration of the time delay before the output devices switch. The 4-20 mA output is not affected by this time delay. To reset the limit output devices, the internal reset push-button or the optional external reset push-button must be pressed. Remote reset by a N.O. push-button or momentary contacts may be made by wiring to the remote reset terminals. Note that the vibration level must be below the trip level for the reset to function.

Startup Trip Delay

Some machines generate vibration levels during startup which are higher than normal running levels. These high vibration levels can exceed the Alarm Trip Limits which are set above the normal running vibration level. The standard SM6100 has a fixed time delay which inhibits alarm trips for 30 seconds from the closing of the startup contacts.

An optional adjustable startup trip delay (1-30 sec.) permits the Alarm Trip Limits to become operative in less than 30 seconds. Protection of machines with short startup times can be improved by utilizing the adjustable Startup Trip delay.

The Startup Trip Delay is triggered by closing a set of contacts (momentary or continuous) connected to the startup terminals. The contacts must be opened before the internal startup delay timer can be initiated again. Connecting these terminals to a set of isolated auxiliary N.O. contacts in a motor starter is a method commonly used to initiate the startup trip delay. The 4-20 mA current output is inhibited (set to 4.0 mA) during the startup trip delay.

Remote Reset Wiring (optional)

If remote reset capability is desired, connect Reset terminals (see Figure 1) to a remotely located, momentary N.O. push-button switch. Observe hazardous area requirements if applicable.

External Sensor

The SM6100 requires the use of an external sensor. Refer to Option G from SM6100 Data-sheet (doc # 1009514) to determine the type of sensor required.

4-20 mA Current Source Output (optional)

If the optional 4-20 mA output is installed it may be connected to a remote receiver, as shown on the wiring diagram (see Figure 1). This output is a current source (at 15VDC) and requires no external loop power supply. Full scale current (20 mA) corresponds to the full scale vibration response marked on the face plate. A current of 4.0 mA represents a zero vibration condition. The maximum load resistance is 600 ohms. In high electrical noise locations a shielded, twisted pair cable is recommended.

FORMULA:
$$\frac{\text{Measured mA} - 4\text{mA}}{20\text{mA} - 4\text{mA}} \times \text{Full scale vibration} = \text{Actual vibration}$$

EXAMPLE:

Measured mA	Full Scale Vibration	Actual Vibration
4.0	1.0 ips, peak	0.0 ips, peak
12.0	1.0 ips, peak	0.5 ips, peak
20.0	1.0 ips, peak	1.0 ips, peak

Dynamic Outputs

The sensor (transducer) signal is available at the terminal block and is capable of driving a cable with a capacitance of up to .03 uF (typically 300m/1000 feet). Longer runs with greater than .03 uF of capacitance can be used without the buffer becoming unstable. However, the frequency response will be reduced due to the increased capacitance.

RECEIVER CONFIGURATION / CALIBRATION

Signal Conditioning Module Output: 4 - 20 mA Source Option

The SM6100 can be factory configured to provide a 4 - 20 mA current source output proportional to the specified full scale vibration response (velocity or displacement). Figure 3 shows suggested programming for a 4-20 mA receiver (PLC, DCS, monitor or computer).

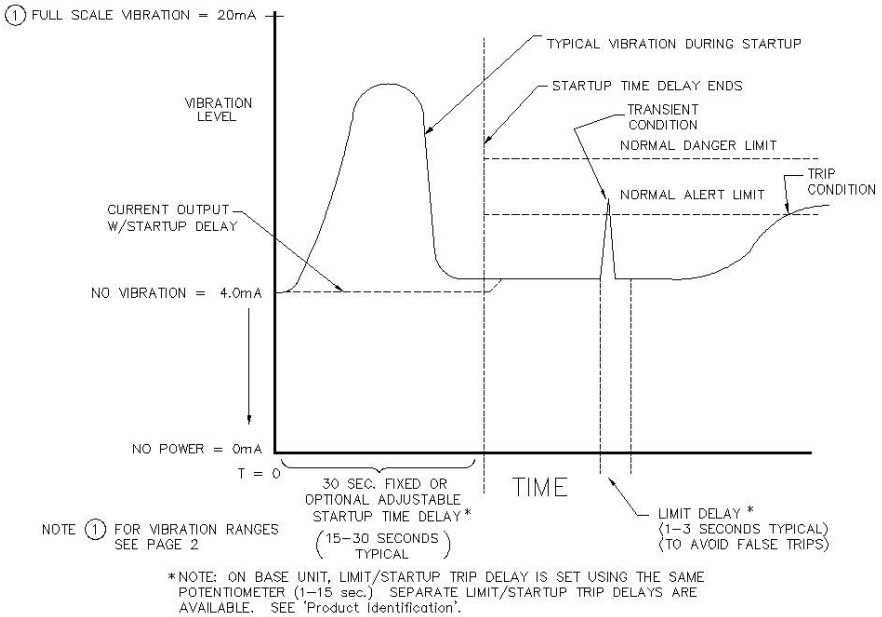

Figure 3: 4-20 mA receiver suggested programming

Vibration Switch Calibration

The SM6100 has been factory calibrated to standards traceable to the U.S. National Institute of Standards and Technology (NIST). If the accuracy is in question, the SM6100 output response can be compared (on an operating machine) with an independent vibration measurement made at the external sensor in the same axis and at the same location with a calibrated vibration analyzer. Ensure that the analyzer is configured with the same frequency response as the SM6100 and with the same unit of measure (i.e. ips pk.). To prevent tampering, there are no user accessible adjustments available for field recalibrating. If recalibration is required, the SM6100 should be returned to the factory for recalibration to a

traceable standard. In field installations, the calibration should be verified at least once per year. In test cell applications, depending upon the severity of handling, correct operation and calibration should be verified each 90-180 days.

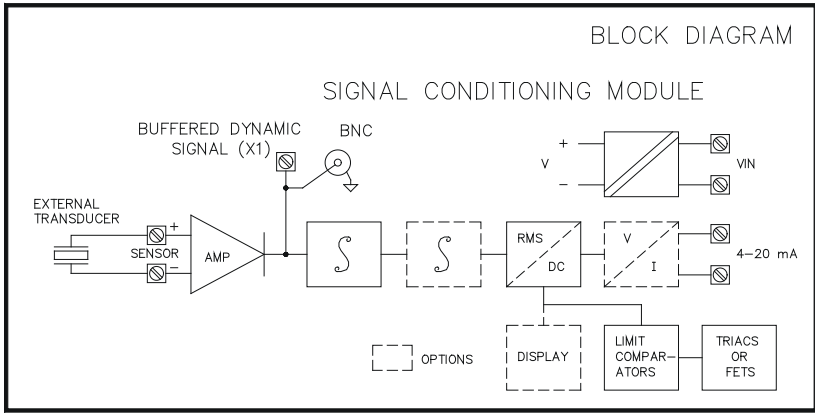

Figure 4: Switch calibration block diagram

Determining Output Voltage

If it is desired to determine either the acceleration or velocity amplitude when one measurement is unknown, the following formulas can be employed.

If g's (A) are known and you wish to determine the velocity output: $V = \frac{3687}{F} \bullet A$

If velocity is known and you wish to determine the displacement output: $D = \frac{19,100}{F} \bullet V$

If g's (A) are known and you wish to determine the displacement output: $D = \left(\frac{8383}{F}\right)^2 \bullet A$

Where V = ips, peak, F = RPM, A = g peak, D = mils, peak-to-peak

Example: $V = \frac{3687}{1800 \text{ RPM}} \bullet 0.5 \text{ g} = 1.02 \text{ ips, peak}$

USER ADJUSTMENTS

Limit Trip Delay

The Limit Trip Delay adjustment allows the user to set the time delay from 1 to 15 seconds. This is useful in avoiding false trips from transient conditions while the machine is running.

Adjustable Startup Trip Delay (optional)

The optional Startup Trip Delay adjustment allows the user to set the time delay from 1 to 30 seconds. This is useful in tailoring the Startup Trip Delay for a particular machine's startup vibration characteristics.

Limit Settings

The Limit Setting adjustment allows to set the vibration levels at which a limit will trip. The adjustment has a range of -10% to 110% of the full scale vibration level. A midscale adjustment corresponds to a 50% vibration level limit. Turning the adjustment to its minimum value (CCW) allows the user to test the trip circuitry, including LED's, time delays and triac (FET) switches. The limit setting can be set precisely by measuring the limit voltage with a DVM. The test points for measuring this voltage are labeled TP3 (Limit 2), TP4 (Limit 1) and COM (common).

The DC voltage represents a percentage of full scale. For example, .46 VDC would represent a limit setting of 46% of full scale. This test should be performed with the machinery not running or switch outputs by-passed.

Caution: After testing, reset the limits to the proper operational values.

Auto Reset

The switch outputs (triacs or FETs) are configured at the factory for latching operation (Figure 5a). The switch outputs can be configured for non-latching operation (Figure 5b) so they automatically reset when the vibration level falls below the alarm limit threshold. To do this, remove power to the unit. Remove the transmitter cover and the display board if present. Refer to Figures 5a &5b (move both jumpers to the auto position). Reassemble the display board and transmitter cover. The switch outputs will now reset when the vibration level falls below the alarm limits.

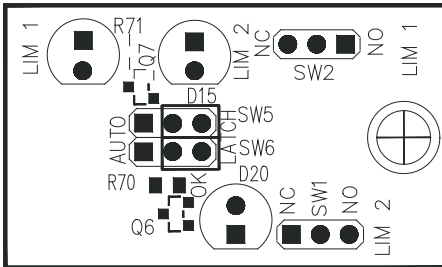

Figure 5a:
Switch Output Configure as
Latched Option (factory default)

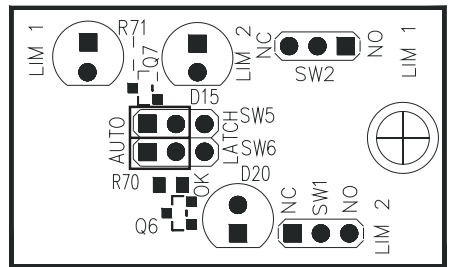

Figure 5b:
Switch Output Configure as Reset Option

CAUTION: This test should be performed with the machinery turned off or switch outputs by-passed. After testing, reset the limits to the proper operational values.

TROUBLESHOOTING

The unit appears to be functioning, but limit operation is in question.

CAUTION: Disconnect or disarm the machine alarms and/or shutdown circuits prior to testing the vibration switch outputs.

- a) Operation of the limit triac/FET and the attached relay can be verified by toggling the NO/NC switch.
- b) The limit setting can be rotated to the minimum (-10%) setting in order to exercise all of the limit control logic and trip delay circuits. The limit triac/FET should operate and the limit LED should turn on after the set trip delay expires. REMEMBER to return the limit setting to the original position after this test.
- c) If the LED is lit but the limit is not functioning, check to make sure the triac/FET load is wired properly and power is present at the limit terminal block and relay.

CAUTION: voltages at the limit switch terminal block can be dangerous. Exercise caution when checking for voltage at the terminal block. For AC loads, ensure the minimum current through the load is 35 mA for temperatures above 25°C or 60 mA below 25°C. For DC loads, ensure proper wiring polarity has been observed.

The unit appears to be functioning, but the 4-20 mA operation is in question.

- a) Ensure that the current loop is wired properly and that the total loop resistance does not exceed 600 ohms. The Model SM6100 4-20 mA circuit is a current source. A voltage source (power supply) must not be used in the circuit.
- b) Verify current output with separate current meter connected in series with the 4-20 mA output and the receiving instrument input. Verify the current is correct. Current output with zero vibration should be 4.0 mA. A 20 mA current represents full scale vibration. Refer to "Wiring: 4-20 mA Current Source Output".

The unit does not respond to vibration input during the first few seconds of operation.

The startup time delay circuit prevents the transmitter from reacting to a vibration input during the startup delay time period. The standard time delay is fixed at 30 seconds. If the unit has the optional variable startup delay, it can be varied from 1 to 30 seconds. The current output is held at 4.0 mA and the display is held at 000 until the startup time delay has expired.

The unit trips the limits shortly after applying power to the unit.

Units with an adjustable startup time delay which is set close to the minimum setting can have the limits trip at power up. This is due to the settling time of the circuitry in the Model SM6100 switch. If a short startup delay is desired, it is suggested that power first be applied to the unit for a minimum of 20 seconds. Power may also be applied continuously. The limits may need to be reset depending on the particular application. Afterwards, the machine can be started in a normal fashion.

The unit is functioning but accuracy is in question.

a) The vibration output can be verified by placing a separate vibration pickup near the external sensor and comparing the two readings. Remember that the vibration meter or analyzer must utilize true RMS detection and have similar frequency response characteristics. Even then, significant differences can exist due to dissimilar sensor orientations, handheld versus rigid mounting, meter or analyzer time constant differences, and other factors. The calibration of the Model SM6100 should be verified on a yearly basis as a minimum.

b) Alternately, the external sensor can be removed and placed on a calibrated shaker system in order to verify the calibration. Metrix can provide factory calibration traceable to NIST standards.

The unit does not appear to be functioning.

Ensure that all wiring connections to the terminal block are correct, terminal screws are tight and that the correct voltage is present at the terminal block power (Vin) terminals. DC voltage polarity is arbitrary. If power is applied, the LCD display (if present) should be functioning, and the current output should be between 4.0 and 20.0 mA.

Sensor “OK” LED is not lit.

This indicates a problem with either the remote sensor or the wiring to the sensor. The sensor may be shorted, open or there may be a defect in the cable. For ICP transducers, ensure that the proper bias voltage is present at the sensor input to the SM6100. This is 12 volts nominal for most accelerometers. For non-powered velocity transducers, ensure that the nominal resistance of the transducer can be measured when the transducer is disconnected from the SM6100.

ENVIRONMENTAL INFORMATION



This electronic equipment was manufactured according to high quality standards to ensure safe and reliable operation when used as intended. Due to its nature, this equipment may contain small quantities of substances known to be hazardous to the environment or to human health if released into the environment. For this reason, Waste Electrical and Electronic Equipment (commonly known as WEEE) should never be disposed of in the public waste stream. The “Crossed-Out Waste Bin” label affixed to this product is a reminder to dispose of this product in accordance with local WEEE regulations. If you have questions about the disposal process, please contact Metrix Customer Service.

info@metrixvibration.com

www.metrixvibration.com

8824 Fallbrook Dr. Houston, TX 77064, USA

Tel: 1.281.940.1802 • Fax: 1.713.559.9421

After Hours (CST) Technical Assistance: 1.713.452.9703